

Model No. EE-MR35
Short Platform Scissor Lift, Mid Rise
Lifting Capacity, 3500KG (8000 lbs)
Electrical Release

**Installation, Operation
and Parts Manual**

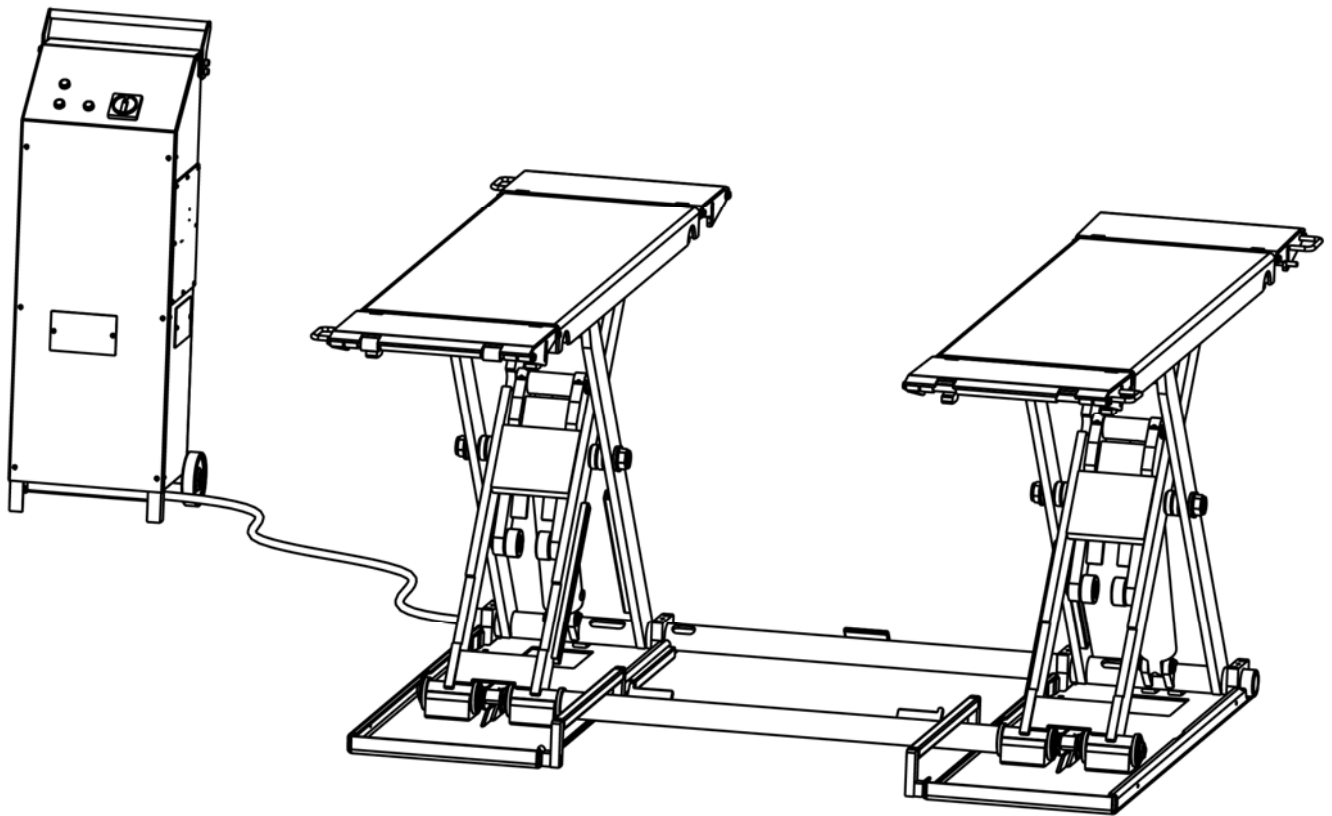

Distributed by

Please read this entire manual carefully and completely before installation or operation of the lift.

Date: 11/03/2024

| | |
|--|----|
| <i>IMPORTANT NOTES</i> | 3 |
| <i>SAFETY NOTES</i> | 4 |
| 1.1 <i>Operation of lifting platforms</i> | 4 |
| 1.2 <i>Checking of the lifting platforms</i> | 4 |
| 1.3 <i>Important safety notices</i> | 5 |
| 1.4 <i>Warning labels</i> | 6 |
| 1.5 <i>Potential safety risks</i> | 7 |
| 1.6 <i>Noise level</i> | 7 |
| <i>PACKING, STORAGE AND TRANSPORTATION</i> | 8 |
| 2.1 <i>The lift was dismantled into 3 parts for transportation</i> | 8 |
| 2.2 <i>Storage</i> | 8 |
| 2.3 <i>Lifting and handling</i> | 8 |
| <i>PRODUCT DESCRIPTIONS</i> | 9 |
| 3.1 <i>General descriptions</i> | 9 |
| 3.2 <i>Construction of the lift</i> | 9 |
| 3.3 <i>Dimensions</i> | 10 |
| 3.4 <i>Safety device descriptions</i> | 11 |
| 3.5 <i>Technical data</i> | 11 |
| <i>INSTALLATION INSTRUCTIONS</i> | 12 |
| 4.1 <i>Preparations before installation</i> | 12 |
| 4.2 <i>Installation attentions</i> | 13 |
| 4.3 <i>General Installation Steps</i> | 13 |
| 4.4 <i>Items to be checked after installation</i> | 14 |
| <i>OPERATION INSTRUCTIONS</i> | 15 |
| 5.1 <i>Precautions</i> | 15 |
| 5.2 <i>Descriptions of control box</i> | 15 |
| 5.3 <i>Flow chart for operation</i> | 15 |
| 5.4 <i>Operation instructions</i> | 16 |
| 5.5 <i>Install the optional mobile kit to move the lift</i> | 17 |
| <i>TROUBLE SHOOTING</i> | 18 |
| <i>MAINTENANCE</i> | 19 |
| <i>Annex 1, Floor plan for fixed installation</i> | 21 |
| <i>Annex 2, Electrical diagrams and parts list</i> | 22 |
| <i>Annex 3, Hydraulic diagrams and parts list</i> | 25 |
| <i>Annex 4, Mechanical exploded drawings and parts list</i> | 29 |

IMPORTANT NOTES

Before start up, connecting and operating EAE products, it is absolutely essential that the operating instructions/owner's manual and, in particular the safety instructions are studied carefully. By doing so you can eliminate any uncertainties in handling EAE products and thus associated safety risks up front; something which is in the interest of you own safety and will ultimately help avoid damage to the device, When an EAE product is handed over to another person, not only the operating instructions but also the safety instructions and information on its designated use must be handed over to the person.

By using the product you agree the following conditions:

Copy right

The enclosed instructions are the property of EAE or its supplier, and are protected against duplication and reproduction by copyright laws, international agreements, and other domestic legislation. The reproduction or disclosure of instructions or an extract thereof is prohibited and offenders are liable to prosecution; EAE reserves the right or initiates criminal proceedings and asserts claims for damages in the event of infringements.

Warranty

The use of non-approved hardware will result in a modification of our products and thus to the exclusion of any liability or warranty, even if such hardware has been removed again in the interim.

It is not permissible to make any changes to our products and these are not only to be used together with genuine accessories and genuine replacement parts. Otherwise any warranty claims will be invalid.

Liability

The liability of EAE is limit to the amount that the customer has actually paid for this product. This exclusion of liability does not apply to damages caused through willful misconduct or gross negligence on the part of EAE.

All information in this manual is believed to be correct at time of publication.

EAE reserves the right to amend and alter technical data and composition without prior notice.

Please confirm at time of ordering.

SAFETY NOTES

1.1 Operation of lifting platforms

This lift is specially designed for lifting motor vehicles. Users are not allowed to use it for any other purposes. The applicable national regulations, laws and directives must be observed.

Only users aged 18 or above who have been instructed on how to operate the lifting platform and have proven their ability to do so to the owner are to be entrusted with unsupervised operation of lifting platforms. The task of operating the lifting platforms must be granted in writing.

Before loading a vehicle onto the lifting platform, users should study the original operation instructions and familiarize themselves with the operating procedures in several trial runs.

Lift vehicle within the rated load. Don't attempt to raise vehicles with excessive weight.

1.2 Checking of the lifting platforms

Checks are to be based on the following directives and regulations:

- Basic principles for testing lifting platforms
- The basic health and safety requirements
- Harmonized European standards
- The applicable accident prevention regulations

The checks are to be organized by the user of the lifting platform. The user is responsible for appointing an expert or qualified person to perform checking. It must be ensure that the person chosen satisfies the requirements.

The user bears special responsibility if employees of the company are appointed as experts or qualified persons.

1.2.1 Scope of checking

Regular checking essentially involves performing a visual inspection and a functional test. This includes checking the condition of the components and equipment, checking that the safety systems are complete and functioning properly and that the inspection log book is completely filled in. The scope of exceptional checking depends on the nature and extent of any structural modification or repair work.

1.2.2 Regular checking

After initial commissioning, lifting platforms are to be checked by a qualified person at intervals of not longer than one year.

A qualified person is somebody with the training and experience required to possess sufficient knowledge of lifting platforms and who is sufficiently familiar with the pertinent national regulations, accident prevention regulations and generally acknowledged rules of engineering to be able to assess the safe operating condition of lifting platforms.

1.2.3 Exceptional checking

Lifting platforms with a lift height of more than 2 meters and lifting platforms intended for use with people standing under the load bearing elements of the load are to be checked by an expert prior or reuse following structural modifications and major repairs to load bearing components.

An expert is somebody with the training and experience required to possess specialist knowledge of lifting platforms and who is sufficiently familiar with the pertinent national work safety regulations, accident prevention regulations and generally acknowledged rules of

engineering to be able to check and give an expert opinion on lifting platforms.

1.3 Important safety notices

1.3.1 Recommend for indoor use only. Do not expose the lift to rain, snow or excessive moisture.

1.3.2 Only use this lift on a surface that is stable and capable of sustaining the load. Do not install the lift on any asphalt surface.

1.3.3 Read and understand all safety warnings before operating the lift.

1.3.4 Do not leave the controls while the lift is still in motion.

1.3.5 Keep hands and feet away from any moving parts. Keep feet clear of the lift when lowering.

1.3.6 Only these properly trained personnel can operate the lift.

1.3.7 Do not wear unfit clothes such as large clothes with flounces, ties, etc., which could be caught by moving parts of the lift.

1.3.8 To prevent evitable incidents, surrounding areas of the lift must be tidy and with nothing unconcerned.

1.3.9 The lift is simply designed to lift the entire body of vehicles, with its maximum weight within the lifting capacity.

1.3.10 Always insure the safety locks are engaged before any attempt to work near or under the vehicle. Never remove safety related components from the lift. Do not use if safety related components are damaged or missing.

1.3.11 Do not rock the vehicle while on the lift or remove any heavy component from vehicle that may cause excessive weight shift.

1.3.12 Check at any time the parts of the lift to ensure the agility of moving parts and the performance of synchronization. Ensure regular maintenance and if anything abnormal occurs, stop using the lift immediately and contact our dealers for help.

1.3.13 Lower the lift to its lowest position and do remember to turn off the power when service finishes.

1.3.14 Do not modify any parts of the lift without manufacturer's advice.

1.3.15 If the lift is going to be left unused for a long time, users are required to:





- a. Disconnect the power;
- b. Empty the oil tank;
- c. Lubricate the moving parts with hydraulic oil.

WARNING: The warnings, cautions and instructions discussed in this instruction manual cannot cover all possible conditions and situations that may occur. It must be understood by the operator that common sense and caution are factors which cannot be built into this product, but must be supplied by the operator.

Attention: For environment protection, please dispose the disused oil in a proper way.

1.4 Warning labels

All safety warning labels are clearly depicted on the lift to ensure that the operator is aware of and avoid the dangers of using the lift in an incorrect manner. The labels must be kept clean and they have to be replaced if detached or damaged. Please read carefully the meaning of each label and memories them for future operation

| | |
|---|---|
|  | CAUTION The operation of the lift is permitted by authorised persons only. |
|  | CAUTION Correctly position the vehicle so as to prevent overturning. |
|  | Center of gravity shall not be placed beyond the area between two support arms. |
|  | CAUTION Observe the load carrying device throughout the motion of the lift. |
|  | CAUTION Carry out maintenance regularly as indicated in the manual. |

The instructions, cautions and warnings written above as well as in the in Manual cannot cover all possible conditions and situations that may occur. The common sense for safety must be always in the mind of the operator. For damages caused through willful misconduct or gross negligence, the lift manufacturer or its distributors are excluded of liability.

| | |
|--|---|
|  | WARNING Travelling on the load carrying devices is forbidden. |
|  | WARNING The field of motion shall be free of obstructions. |
|  | WARNING Avoid excessive rocking of vehicle while on the lift. |
|  | DANGER Never raise just one end, one corner or one side of vehicle. |
|  | DANGER Do not remove, modify or interrupt safety related components or devices. |

1.5 Potential safety risks

1.5.1 Mains voltage



Insulation damage and other faults may result in accessible components being live

Safety measures:

- Only ever use the power cord provided or a tested power cord.
- Replace wires with damaged insulation.
- Do not open the operating unit.

1.5.2 Risk of injury, danger of crushing

In the event of excessive vehicle weight, incorrect mounting of the vehicle or on removing heavy object, there is a risk of the vehicle falling off the lifting platform or tipping up.

Safety measures:

- The lifting platform is only ever to be employed for the intended purpose.
- Carefully study and heed all the information given in section 1.4.
- Observe the warning notices for operation.

1.6 Noise level

Noise emitted during operating the lift should be less than 70dB(A). For your health consideration, it is suggested to place a noise detector in your working area.

PACKING, STORAGE AND TRANSPORTATION

Packing, lifting, handling, transporting operations must be performed only by experienced personnel with appropriate knowledge of the lift and after reading this manual.

2.1 The lift was dismantled into 3 parts for transportation

| <i>Name</i> | <i>Packed by</i> | <i>Dimension</i> | <i>Weight(lbs)</i> | <i>Quantity</i> |
|--------------------------------|--------------------------------|---|--------------------|-----------------|
| <i>Control cabinet</i> | <i>Wooden case</i> | <i>540*430*1150 (21 1/4" x 16 15/16" x 45 1/4")</i> | <i>165</i> | <i>1</i> |
| <i>Lifting platform</i> | <i>Carton with wooden base</i> | <i>2050*2050*200 (80 11/16" x 80 11/16" x 7 7/8")</i> | <i>1200</i> | <i>1</i> |
| <i>Portable kit (Optional)</i> | <i>Carton</i> | <i>310*220*120 (12 3/16" x 8 11/16" x 4 3/4")</i> | <i>35</i> | <i>1</i> |

2.2 Storage

The packs must be kept in a covered and protected area in a temperature range of -10°C to $+40^{\circ}\text{C}$. They must not be exposed to direct sunlight, rain or water.

Stacking the packs

We advise against stacking because the packs are not designed for this type of storage. The narrow base, heavy weight and large size of the packs make stacking difficult and potentially dangerous.

If stacking is unavoidable, use all appropriate precautions:

-never stack to more than 2 meters in height.

-never make stacks of single packs. Always stack pairs of packs in a cross pattern so that the base is bigger and the resulting stack is more stable. Once the stack is complete, restrain it using straps, ropes or other suitable methods.

A maximum of two packs can be stacked on lorries, in containers, and in railway wagons, on condition that the packs are strapped together and restrained to stop them falling.

2.3 Lifting and handling

The packs can be lifted and transported only by using lift trucks.

Opening the packs

When the lift is delivered, make sure that it has not been damaged during transportation and that all the parts are present.

Packs must be opened adopting all the precautions required to avoid injury to persons (keep at a safe distance when cutting the straps) or damage to parts of the machine (be careful that no parts are dropped while you are opening the packing)

Take special care with the hydraulic power unit, the control panel and the platform cylinder.

PRODUCT DESCRIPTIONS

3.1 General descriptions

This model is chassis supporting vehicle lift for road vehicles. It is driven by an electro-hydraulic system and designed for mobile use with a maximum lifting height of 39 3/8" (1000mm). The gear pump delivers hydraulic oil to oil cylinders and pushes upwards pistons to raise the platforms. In the process of rising, the mechanical locking unit ensures no unexpected fall caused by failure of hydraulic system. Besides, designs like, 24V working voltage of control box and limit switch, anti-surge valves, etc. have fully considered operator's personal security.

3.2 Construction of the lift

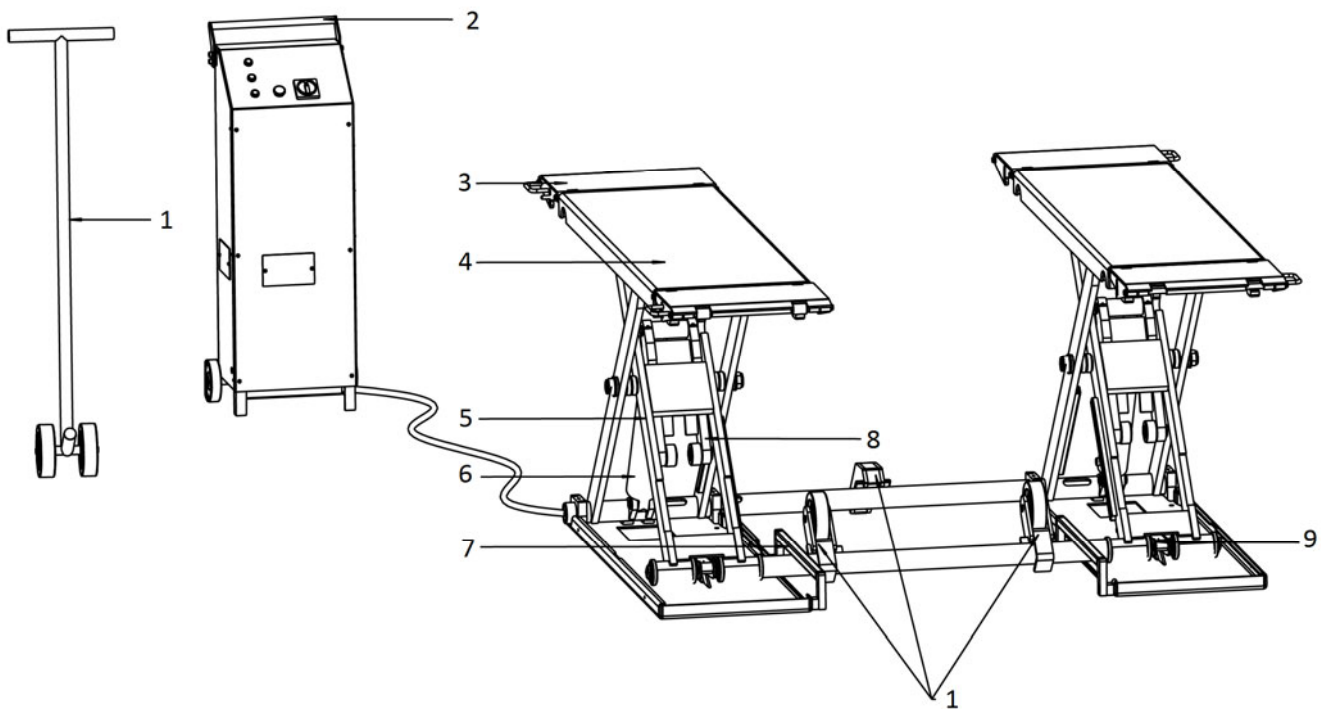

1. Mobile kit (optional)
2. Operation unit
3. Drive-on ramp
4. Lifting platform
5. Support scissor bracket
6. Oil cylinder
7. Tip-off protection unit
8. Start plate
9. Mechanical safety lock

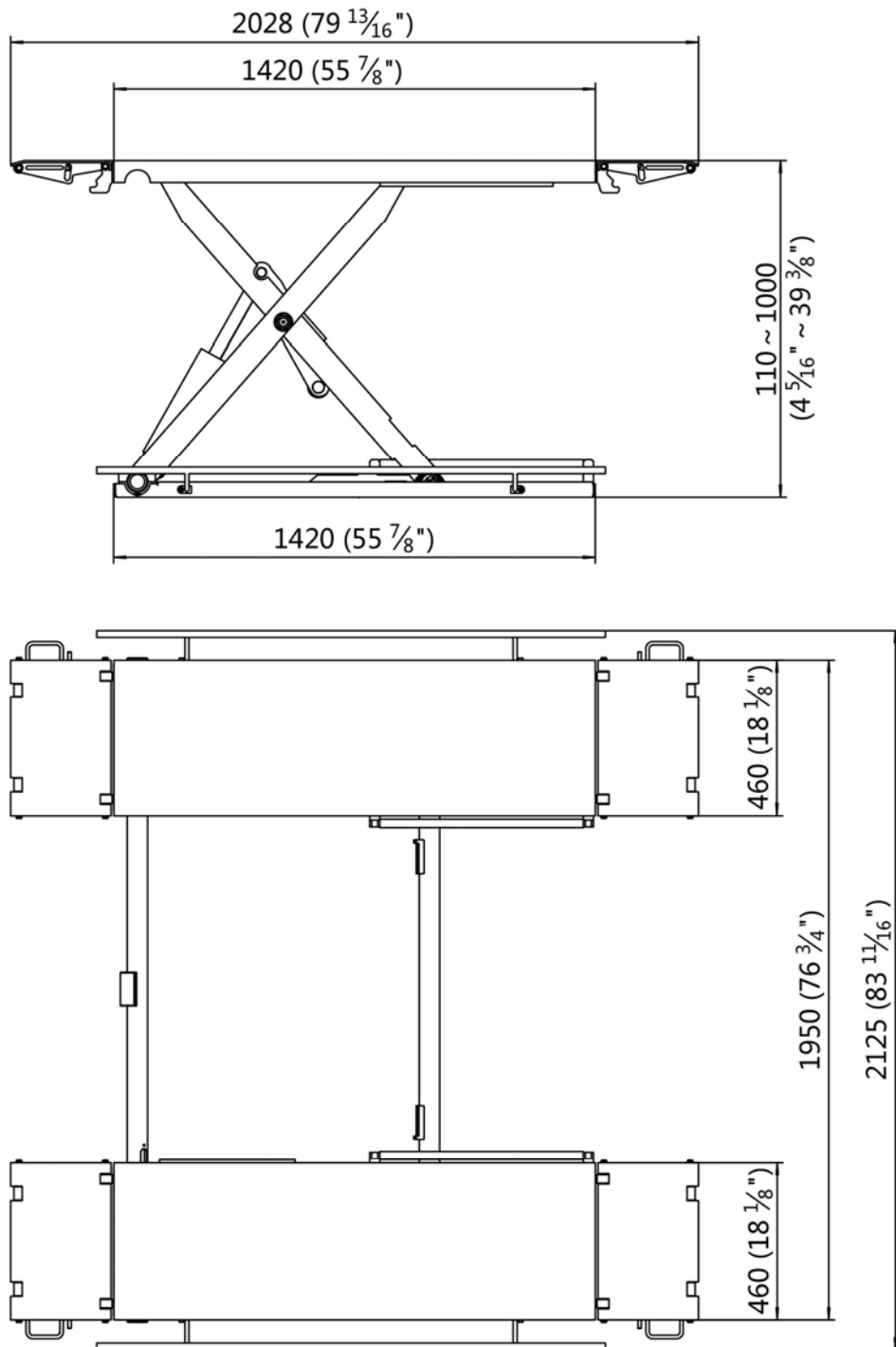
3.3 Dimensions

3.4 Safety device descriptions

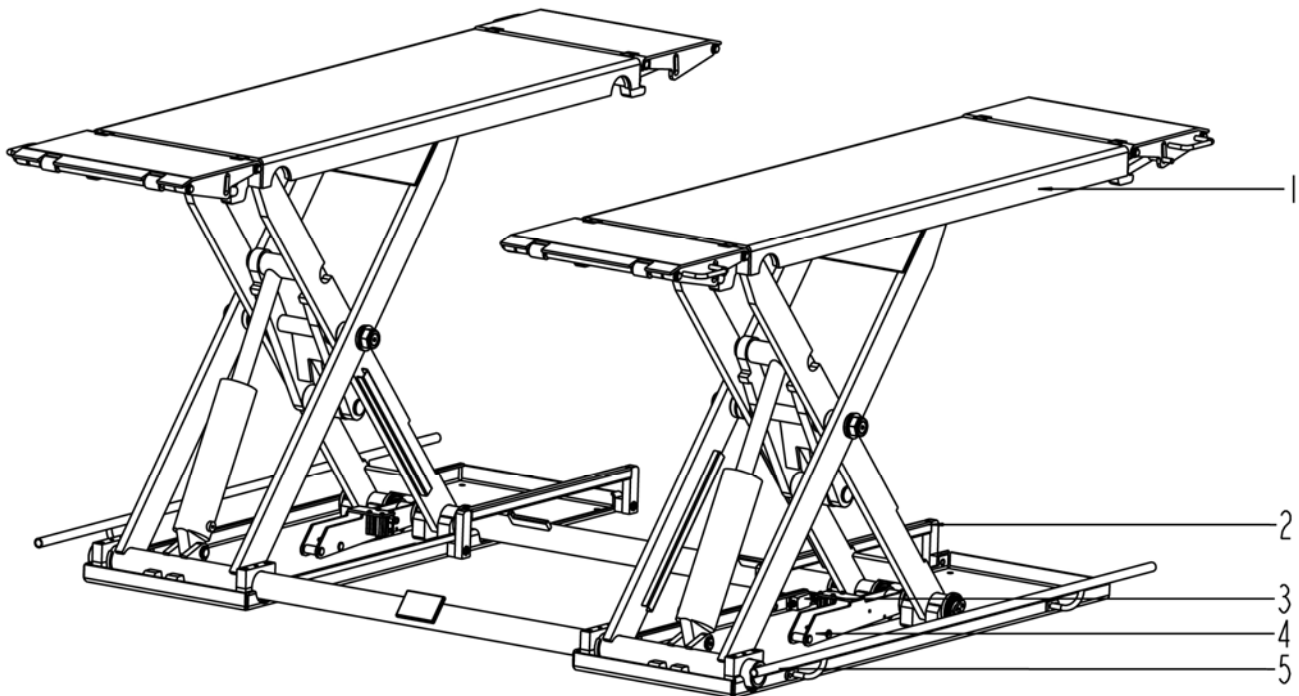

1. *Tip-off protection under the platform*
2. *Tip-off protection fender*
3. *Max height limit switch*
4. *Mechanical safety lock*
5. *Feet protection fender*

3.5 Technical data

| | |
|-------------------------------------|-------------------|
| Rated capacity | 3500kg (8000 lbs) |
| Full raised height | 1000mm (39 3/8") |
| Initial height | 110mm (4 5/16") |
| Full raised time (with rated load) | Approx.30s |
| Full lowered time (with rated load) | ≤15s |
| Hydraulic working pressure | 24 MPa |
| Motor | 2.2kW |
| Oil tank | 6L |

INSTALLATION INSTRUCTIONS

4.1 Preparations before installation

4.1.1 Space requirements.

Refer to 3.3 for the dimensions of the lift. There must also be a clearance of at least 1 meter (39 3/8") between the lifting platform and fixed elements (e.g. wall) in all lifting positions. There must be sufficient space at the ends of the lifting platform for driving vehicles on and off.

To stop vehicles colliding with the ceiling, it is advisable to fit an overhead light barrier in low ceiling buildings.

4.1.2 Foundations and connections

Only use this lift on a surface that is stable, level and dry and not slippery, and capable of sustaining the load. This lift must be installed on a solid level concrete floor with no more than 3-degrees of slope. Failure to do so could cause personal injury or death. Do not install or use the lift on any asphalt surface.

The user must have the following work performed before erecting the lift.

- Construction of the foundation following consultation with the manufacturer's customer service or an authorized service agent.
- Routing of the wiring to the installation location. Refer also to the corresponding information on the name plate and in the operation instructions. Before doing electrical connection, make sure the lift is electrically adapt to the local power supply.
- The user must provide fuse protection for the connection. Requirements for power supply cable of the installation site: at least 2.5mm² wire core for 3Ph power and 4.0mm² wire core for 1Ph power. *Attention: electrical system connection must be done by licensed technicians.*
- Routing of the compressed air connection to the installation location.

4.1.3 Foundations preparations

There must be a clearance of at least 1 meter between the lifting platform and fixed elements (e.g. wall) in all lifting positions.

There must also be sufficient space for driving vehicles on and off.

C25-C30 concrete foundation with a minimum thickness of 150mm (5 7/8").

Surface: Horizontal and even (Gradients max. 0.5 %).

Newly built concrete ground must be older than 20days.

4.1.4 Tools and equipment needed for installation

| Tool name | Specification | Qty |
|--|----------------------------|-----|
| Electrical drill (Only necessary to fixed installation) | With D12 drill bit. | 1 |
| Open spanner | D17-19mm | 2 |
| Cross socket screw driver | PH2 | 1 |
| Socket spanner | D24mm | 1 |
| Lifting equipment | Capacity 1000kg (2200 lbs) | 1 |

4.1.5 Checking parts

Unfold the package and check if any parts missed as per the following list. Do not hesitate to contact us in case any parts missed, but if you do not contact us and insist installing upon the lack of some parts, we as well as our dealers will not bear any responsibility for this and will charge for any parts subsequently demanded by the buyer.

| S/N | Name | Specification | Qty |
|-----|--------------------------------|--|----------|
| 1 | MR35 Mechanical Assembly | MR35-00 | 1 |
| 2 | Portable kit | | Optional |
| 2.1 | Wheel | MR30-A25-B1 | 2 |
| 2.2 | Prop trough | MR30-A25-B2 | 1 |
| 2.3 | All directional wheel | MR30-A25-B3 | 1 |
| 3 | Feet protection fenders | MR30-A1-B7 | 2 |
| 4 | Power and control unit | MR30-A24 | 1 |
| 5 | Rubber pad | 38*120*100 (1 1/2" x 4 3/4" x 3 15/16") | 4 |
| 5 | Rubber pad (optional) | 120*100*70 (4 3/4" x 3 15/16" x 2 3/4") | 4 |
| 6 | Hex socket cylinder head screw | M8*12 | 4 |

4.2 Installation attentions

4.2.1 Joints of oil hoses and wires must be well connected in order to avoid leakage of oil hose and looseness of electrical wires.

4.2.2 All bolts should be firmly screwed up.

4.2.3 Do not place any vehicle on the lift in the case of trial running.

4.3 General Installation Steps

Step 1: Place the lifting platform at expected installation site.

Please do read and understand this manual thoroughly before next step.

Step 2: Dismantle the package of the lifting platforms.

Remove the carton and packing films wrapped on the platform.

Avoid scratching the paint and hoses.

Step 3: Open the package of the control cabinet and take out accessories in it.

Step 4: Connect oil hoses.

Refer to Annex 3.

Connect the fitting of oil hose and its tie-in on the hydraulic block tightly.

Attention: Do not contaminate the hydraulic components during the connection.

Step 5: Connect electrical system.

Refer to Annex 2.

Read the name plate of the motor and understand the wiring diagram before connecting the power supply.

Open the control box and connect electrical wires respectively with the terminals reserved in it.

Pay attention to the number tubes attached with each wire. Wires and terminals with the same number marking are going to be connected together.

Step 6: Fill with hydraulic oil.

CLEAN AND FRESH OIL ONLY. DON'T FILL THE TANK COMPLETELY FULL.

Lift must be fully lowered before changing or adding hydraulic oil

Prepare 5 liters (1.32 us gal) of hydraulic oil. The level of oil shall reach the tippets volume mark of the tank.

Add more oil after running the lift for several cycles until the lift can rise to the maximum lifting height.

Note: It is suggested to use HM NO.46 hydraulic oil. Use HM NO.32 hydraulic oil when average temperature of the location is 10 degree Celsius. **Change the oil 6 months after initial use and change once per year thereafter.**

Step 7: Trial running.

Get familiar with lift controls before loading vehicle onto the lift.

No abnormal sound or leakage before loading.

Run the lift for 5-6 cycles without load. The cylinder is self-bleeding. After bleeding system, fluid level in power unit reservoir may be down.

Add more oil if necessary to raise lift to full height. It is only necessary to add oil to raise lift to full height.

(For three phase power supply, if the lift doesn't raise and the motor may turn in the wrong direction, in such event, interchange wires U, V in the control cabinet).

Note: Refer to Annex 1 for fixed installation.

Step 8: Fix the feet protection fenders.

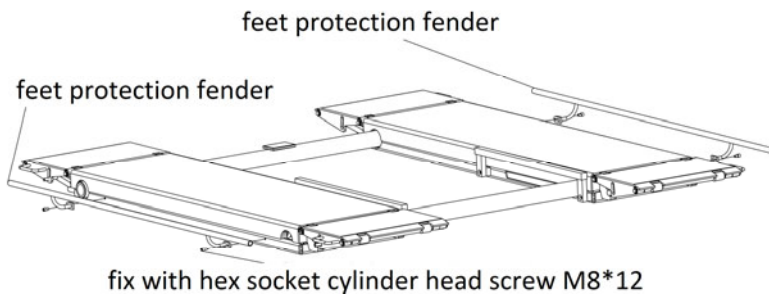

4.4 Items to be checked after installation.

| S/N | Check items | YES | NO |
|-----|---|-----|----|
| 1 | Rising speed $\geq 20\text{mm/s}$; | √ | |
| 2 | Noise with rated load $\leq 75\text{dB(A)}$; | √ | |
| 3 | Grounding resistance: not bigger than 4Ω ; | √ | |
| 4 | Mechanical locks are robust and synchronized when running with rated load ; | √ | |
| 5 | If the control button works as "hold to run"? | √ | |
| 6 | If limit switches work well? | √ | |
| 7 | If grounding wire is connected? | √ | |
| 8 | If rise and lower smoothly? | √ | |
| 9 | If there is no abnormal noise during running with rated load? | √ | |
| 10 | If there is no oil leakage when running with rated load? | √ | |
| 11 | If there is no air leakage when running with rated load? | √ | |
| 12 | If all bolts, nuts or circlips are well secured? | √ | |
| 13 | If max lifting height is 1000mm ($39\ 3/8"$)? | √ | |
| 14 | If safety advices, name plate and logos are clear? | √ | |

OPERATION INSTRUCTIONS

5.1 Precautions

- 5.1.1. Read and digest the complete operation instructions before operating the lift.
- 5.1.2. Only authorized persons are permitted to operate the lift.
- 5.1.3. Do not try to raise the vehicle with excessive length or width.
- 5.1.4. The space above and below the load as well as of the loading carrying devices shall be free of obstructions.
- 5.1.5. Position supporting pads to pick-up positions recommended by vehicle manufacturers.
- 5.1.6. Check the vehicle after raising a short distance to ensure that it is corrected and safely positioned.
- 5.1.7. The load carrying device shall be observed by the operator throughout the motion of the lift.
- 5.1.8. Avoid excessive rocking of vehicle while on the lift
- 5.1.9. It is forbidden for people to stand in the field of motion during raising or lowering movement.
- 5.1.10. Do not climb onto the load or load carrying device when they are raised.

5.2 Descriptions of control box

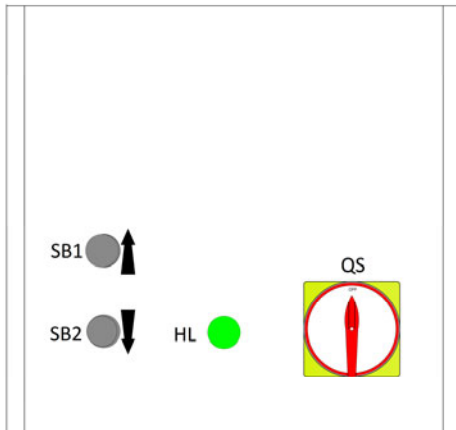

| Pos. | Name | Function |
|------|-----------------|----------------------------------|
| QS | Power switch | Control main power |
| HL | Power indicator | Show if electricity is connected |
| SB1 | UP button | Control the rising movement |
| SB2 | DOWN button | Control the lowering movement |

5.3 Flow chart for operation

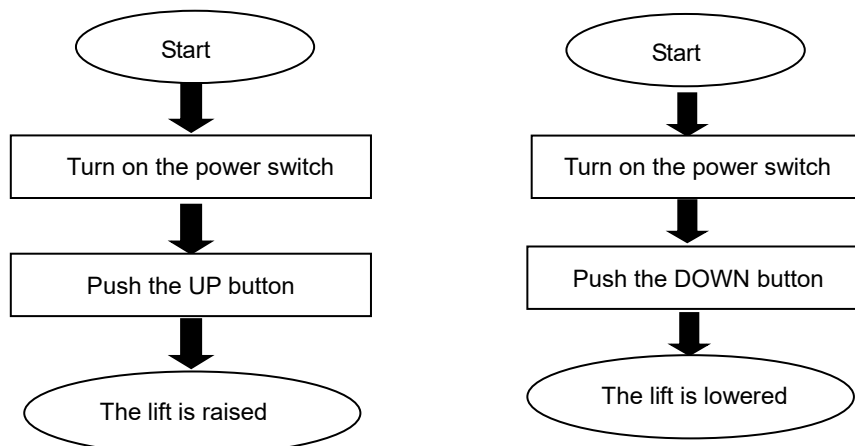

5.4 Operation instructions

The lift must be only used in a static position for lifting and lowering vehicles.

Only use this lift on a surface that is stable and capable of sustaining the load.

Do not use the lift on any asphalt surface.

To avoid personal injury and/or property damage, permit only trained personnel to operate the lift. After reviewing these instructions, get familiar with lift controls by running the lift through a few cycles before loading vehicle on lifting platform.

Always lift the vehicle using all four adapters. Never raise just one end, one corner or one side of vehicle.

Raise the lift

Make sure vehicle is neither front nor rear heavy and center of balance should be midway between adapters and centered over the lift.

1. Make sure that you have read and understood the operation manual before operation.
2. Load vehicle on lift carefully. Position the lift adapters to contact at the vehicle manufacturer's recommended lift points.
3. Push the UP button to raise lift until adapters contact vehicle.
4. Check adapters for secure contact with vehicle. Raise lift to expected working height.

Lower the lift

When lowering the lift pay careful attention that all personnel and objects are kept clear.

1. Push the DOWN button to lower the lifting platform.
2. After the lifting platform is fully lowered, remove rubber pads and other tools to provide an unobstructed exit for moving vehicle from the lift area.
3. Drive the vehicle away.

5.5 Install the optional mobile kit to move the lift



**Always take away all accessories of the optional kit for movable use before loading.
Never attempt to transport the lift when it is loaded.**

1. Raise the platform about 500mm above the floor and fix the mobile kit as indicated in the below fig.

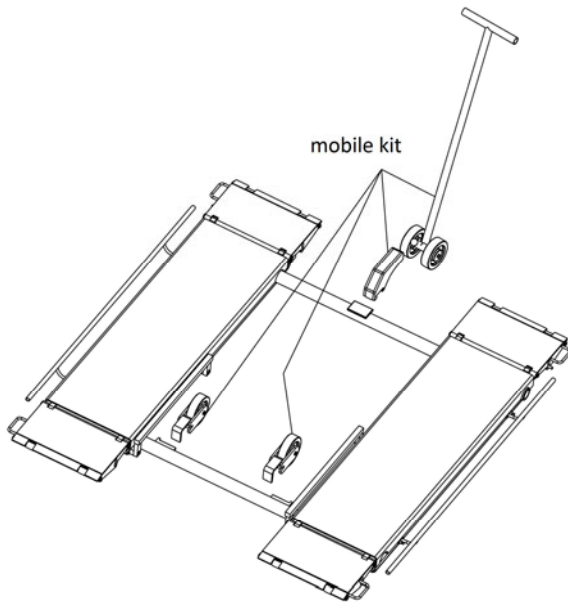

2. Lower the platform to the lowest position.

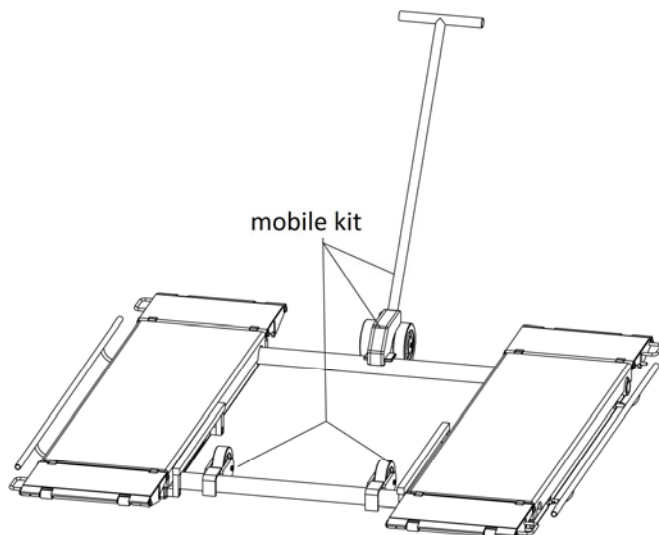

3. Move the lift

TROUBLE SHOOTING

ATTENTION: If the trouble could not be fixed by yourself, please do not hesitate to contact us for help .The troubles will be judged and solved much faster if more details or pictures of the trouble could be provided.

| TROUBLES | CAUSES | SOLUTIONS |
|--|---|-------------------------------------|
| Motor does not run and will not raise. | Loose wire connection | Check and make a good connection. |
| | Burnt motor. | Replace it. |
| | Damaged limit switch or its wire connection is loose. | Adjust or replace the limit switch. |
| Motor runs but will not raise. | The motor run reversely. | Check the wire connection. |
| | Overflow valve is not well screwed up or jammed. | Clean or make adjustment |
| | Damaged gear pump. | Replace it. |
| | Too low oil level. | Add oil. |
| | The hose connection is loose. | Tighten it. |
| | The cushion valve is not well screwed up or jammed. | Clean or make adjustment |
| Platforms go down slowly after being raised. | The oil hose leaks. | Check or replace it. |
| | Untightened oil cylinder. | Replace the seal. |
| | The single way valve leaks. | Clean or replace it. |
| | Solenoid valve fails to work well. | Clean or replace it. |
| | Unloading valve leaks. | Check and adjust the tightness. |
| Raising too slow. | Jammed oil filter | Clean or replace it. |
| | Too low oil level. | Add oil. |
| | The overflow valve is not adjusted to the right position. | Make adjustment. |
| | Too hot hydraulic oil (above 45°). | Change the oil. |
| | Abraded seal of the cylinder | Replace the seal. |
| Lowering too slow. | Jammed throttle valve | Clean or replace it. |
| | Dirty hydraulic oil | Clean or replace. |
| | Jammed anti-surge valve | Change the oil. |
| | Jammed oil hose | Clean it. |

MAINTENANCE

Easy and low cost routine maintenance can ensure the lift work normally and safely.

Follow the below routine maintenance schedule with reference to the actual working condition and frequency of your lift.

Lubricate moving parts with No.1 lithium base grease.

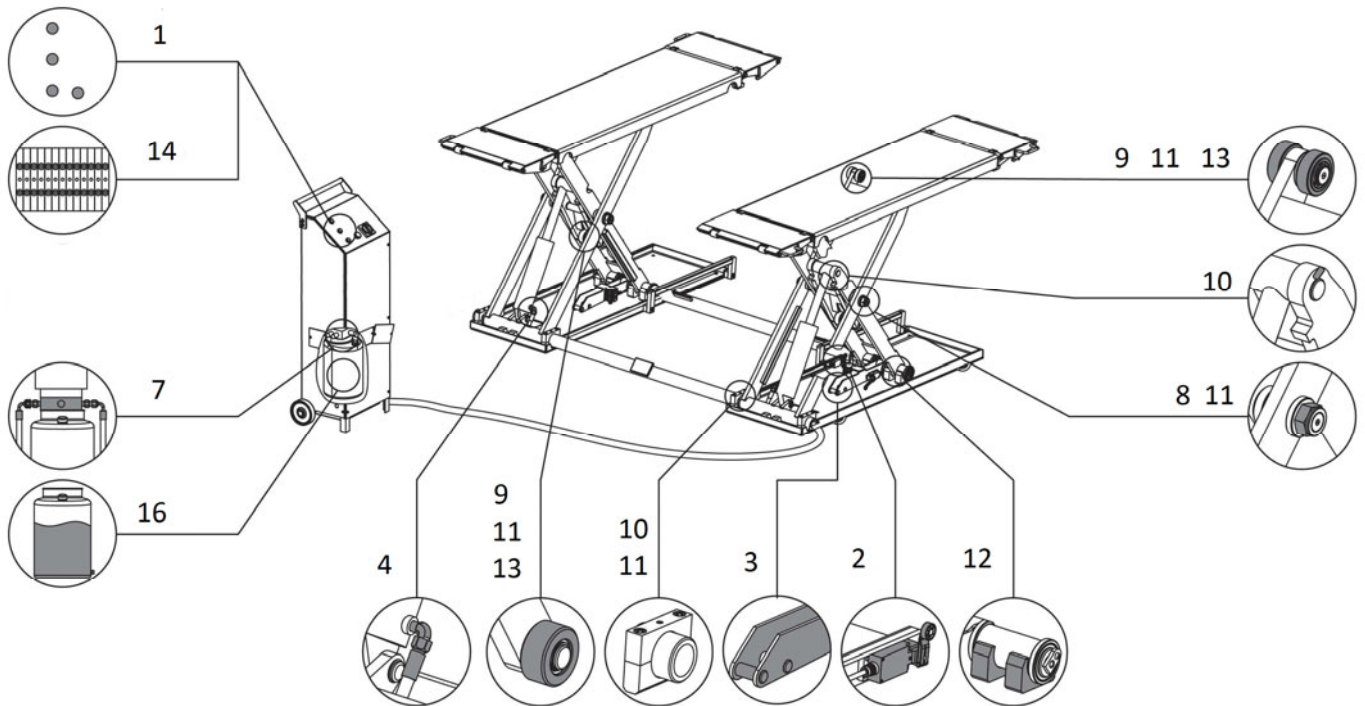

| S/N | Components | Methods | Period |
|-----|----------------------------|--|----------------|
| 1 | Control buttons | Check if control buttons work as "hold- to -run " and check if they work as the function indicated. | Every day |
| 2 | Max height limit switch | Push the UP button and inspect and ensure the lifting platform stops rising at maximum lifting height. | Every day |
| 3 | Mechanical safety catch | Check if both mechanical catches can engage and disengage simultaneously by pushing control buttons. | Every day |
| 4 | Oil hoses and connectors | Inspect to ensure no leakage before using the lift. | Every day |
| 7 | Hydraulic block and valves | Inspect if the valves leak or not. Clean or change the valve if any leakage. | Every month |
| 8 | Self-locking nut | Check with torque spanner. The torque should be no less than 243 lbf.ft (330N.m). | Every month |
| 9 | Circlips | Inspect if any circlip goes off its groove. Make sure they are positioned in the grooves. | Every month |
| 10 | Locking screw | Inspect to ensure the screws are well fastened. | Every month |
| 11 | Joint shafts | Add grease into the oil cups. | Every 3 months |
| 12 | Sliders | Add grease onto the running tracks to ensure smooth running. Check if the sliders are over-worn. Change over-worn sliders. | Every 3 months |

| S/N | Components | Methods | Period |
|-----|----------------------------------|---|----------------|
| 13 | Upside rollers and start rollers | Push the UP and DOWN button to check if the roller is over-worn or cannot roll. Add grease to ensure smooth running. Change over-worn rollers. | Every 3 months |
| 14 | Terminals in the control unit | Open the control unit, inspect the wire terminals and screw firmly if any terminals become loose. | Every 3 months |
| | Whole Lift | Running the lift for several cycles with and without rated load. The lift can run steadily and smoothly with no abnormal noise. | Every 3 months |
| 16 | Hydraulic oil | Change the oil 6 months after initial use and once per year thereafter. Inspect the hydraulic oil and change the oil if the oil becomes black or there is dirt in the oil tank. | Every year |

If users stick to the above maintenance requirements, the lift will always keep a good working condition and its service life could be extended.

Annex 1, Floor plan for fixed installation

Indoor installation only.

There must also be a clearance of at least 1 meter (39 3/8") between the lifting platform and fixed elements (e.g. wall) in all lifting positions. There must be sufficient space for driving vehicles on and off.

C25/30 concrete foundation with a minimum thickness of 150mm (5 7/8").

Surface: Horizontal and even (Gradients max. 0.5 %)

Newly built concrete ground must be older than 20days.

In mm.

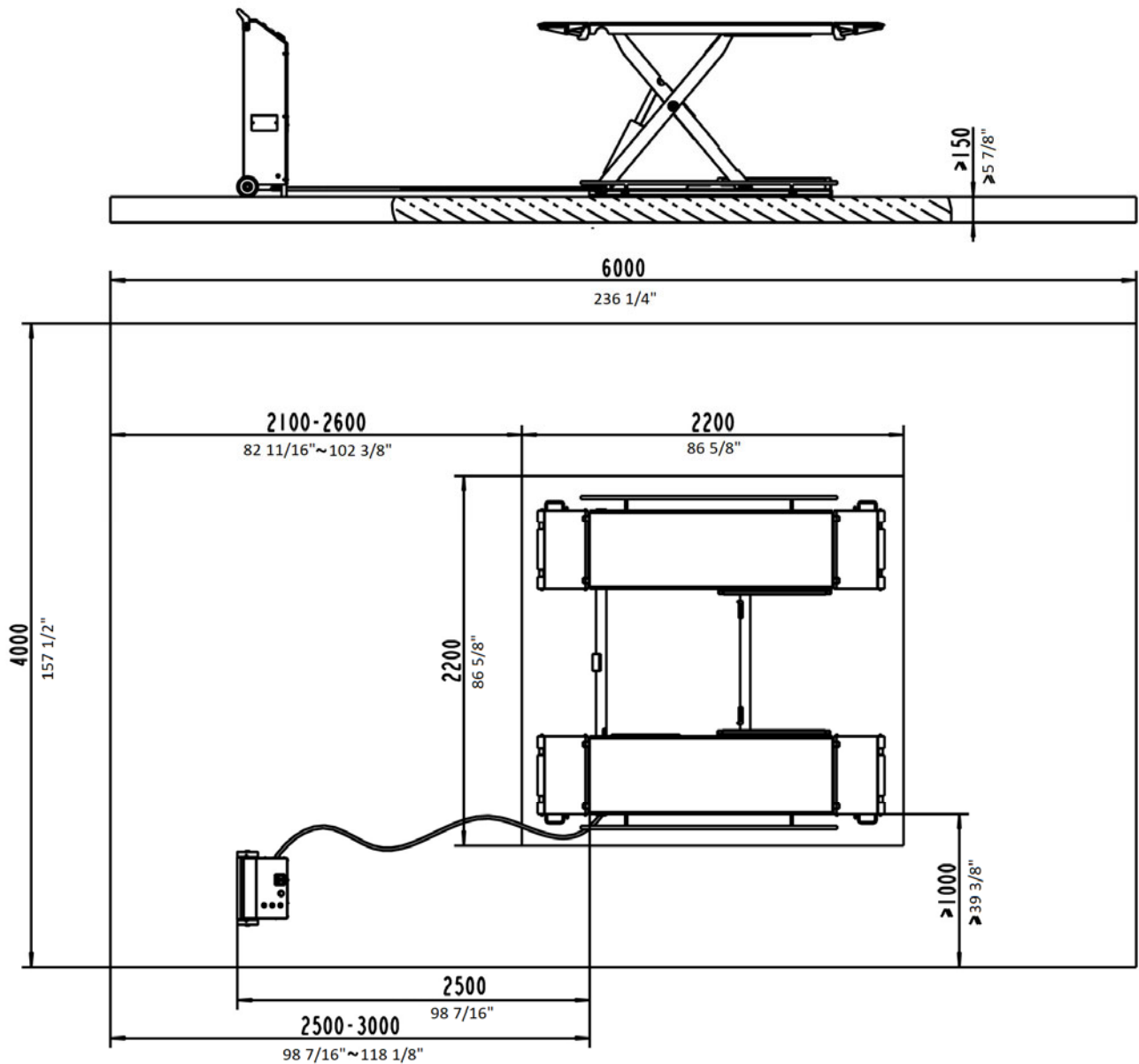

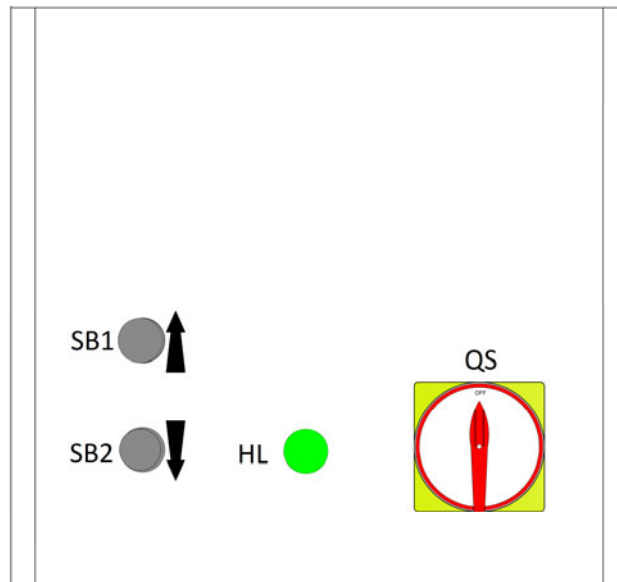
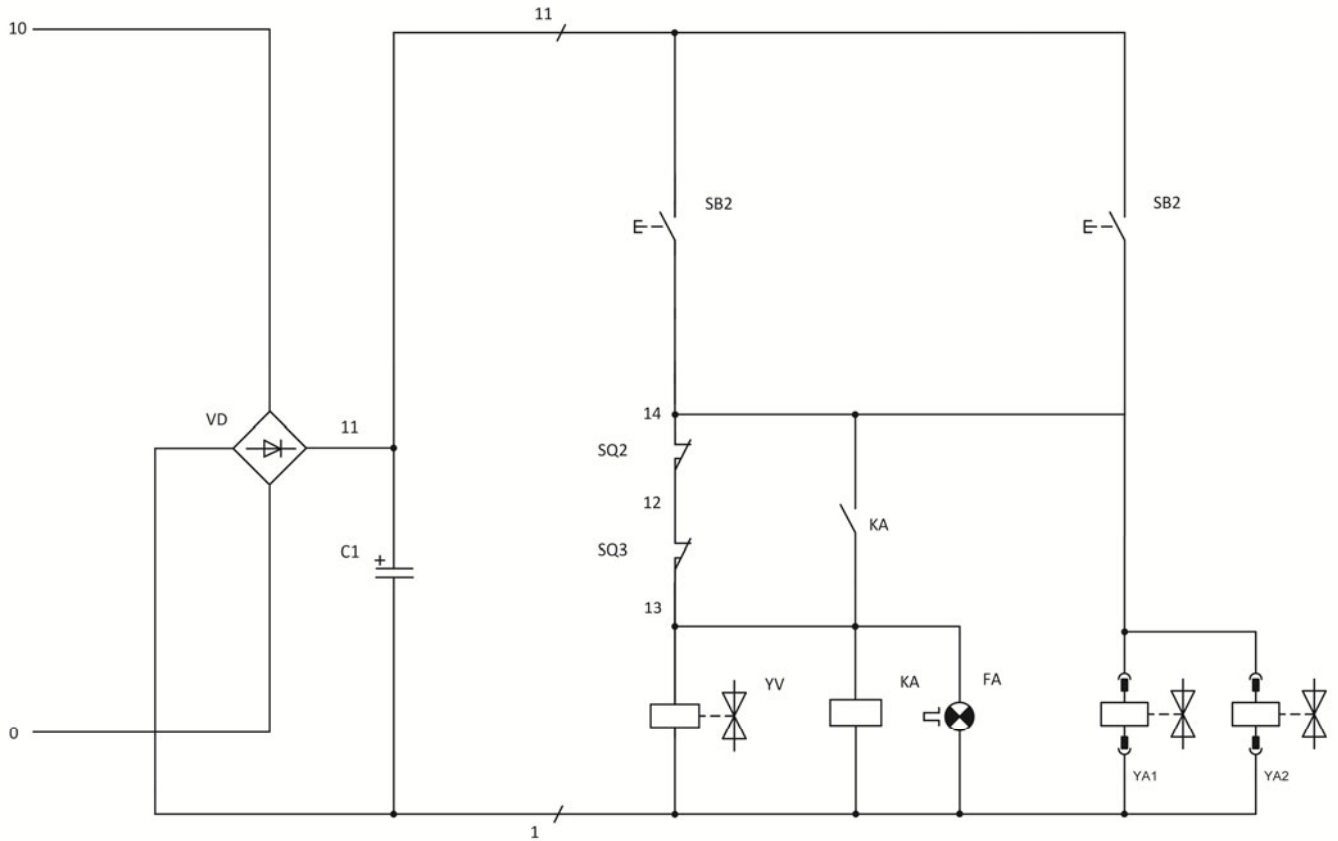

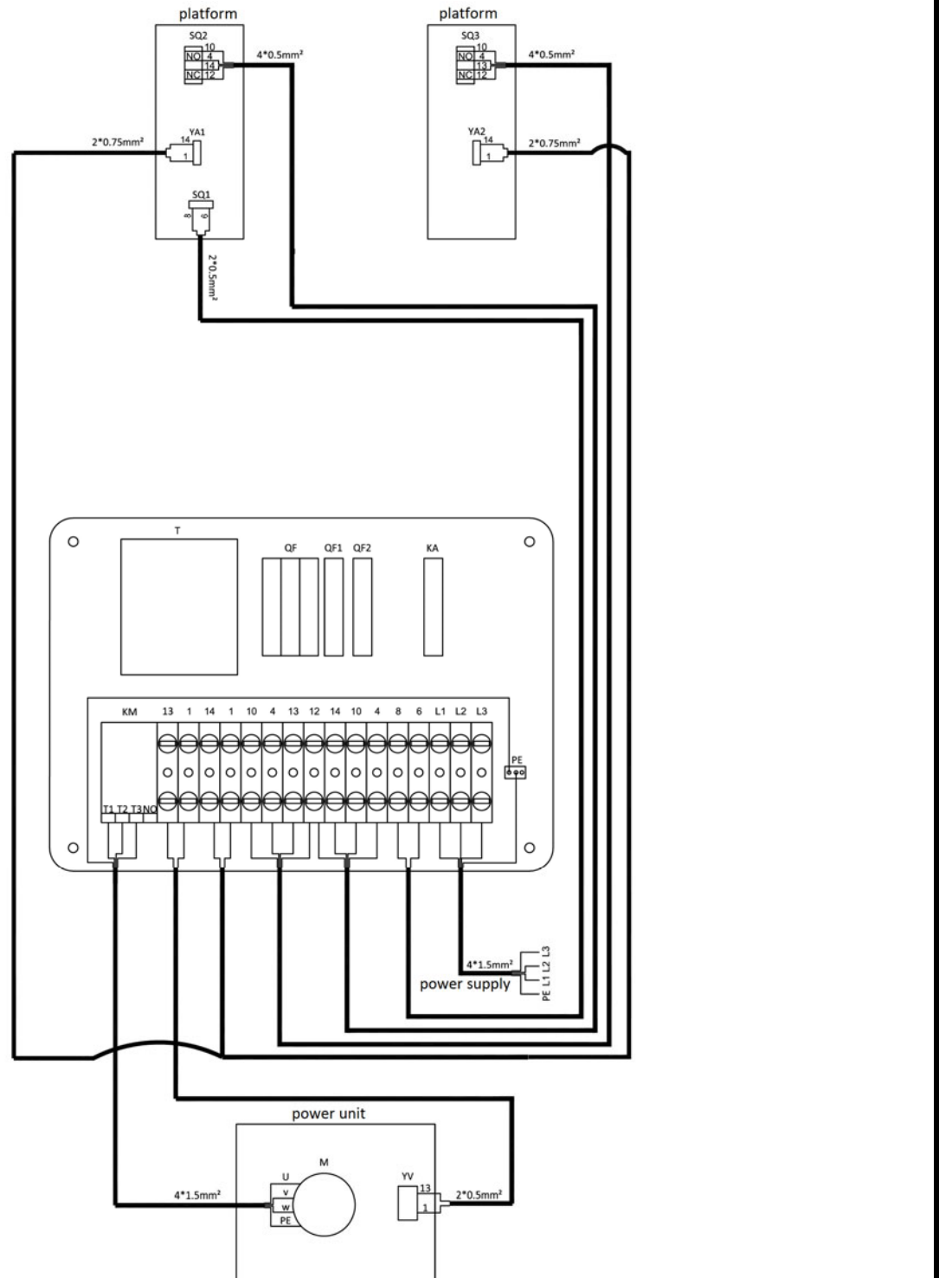

NOTE: There's no internal wire connected with terminal 12.

The two wires which comes from SQ2 and SQ3 and marked with NO.12 share the same terminal 12.

| Supply cable | Yellow-Green | Blue | Other colors |
|--------------|--------------|--------------|--------------|
| 3 wires | Earth wire | Neutral wire | Phase wire |

| Pos. | Code | Description | Qty |
|-------------|------------|------------------------------|-----|
| T | 320101137 | Transformer 110V-24V | 1 |
| T | 320104009 | Transformer 220V230V240V-24V | 1 |
| SQ1,SQ2,SQ3 | 320301011 | Limit switch (TZ8108) | 3 |
| YA1,YA2 | 330310018B | Electromagnet | 2 |
| QS | 320304001 | Power switch | 1 |
| SB1 | 320402013 | Button | 1 |
| SB2 | 320402016 | Button | 1 |
| KA | 320601005 | Relay | 1 |
| | 320601009 | Relay holder | 1 |
| | 320601018 | Relay fixer | 2 |
| QF | 320802002 | Circuit breaker | 1 |
| QF | 320802001 | Circuit breaker | 1 |
| QF1 | 320803003 | Circuit breaker | 1 |
| QF2 | 320803006 | Circuit breaker | 1 |
| KM | 320901011 | AC contactor | 1 |
| C | 321001004 | Capacitor | 1 |
| VD | 321002001 | Rectifier | 1 |
| HL | 321201001 | Power indicator | 1 |
| | 320701096 | Plug (Optional) | 1 |

NOTE: For power supply of other voltage, the transformer is different.
Please check with our customer service people when order spare parts.

Annex 3, Hydraulic diagrams and parts list

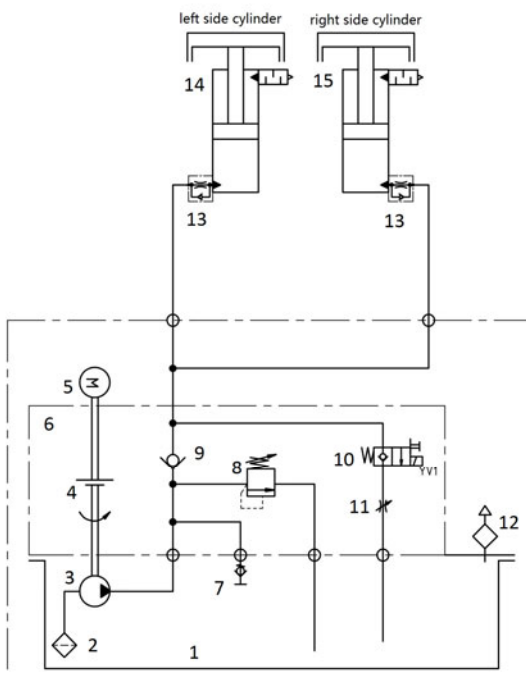

- 1.oil tank
- 2.oil sucking filter
- 3.gear pump
- 4.coupling
- 5.motor
- 6.hydraulic block
- 7.cushion valve
- 8.overflow valve
- 9.single way valve
- 10.solenoid unloading valve
- 11.throttle valve
- 12.oil tank cover
- 13.hose connector (single way throttle valve included)
- 14.cylinder
- 15.cylinder

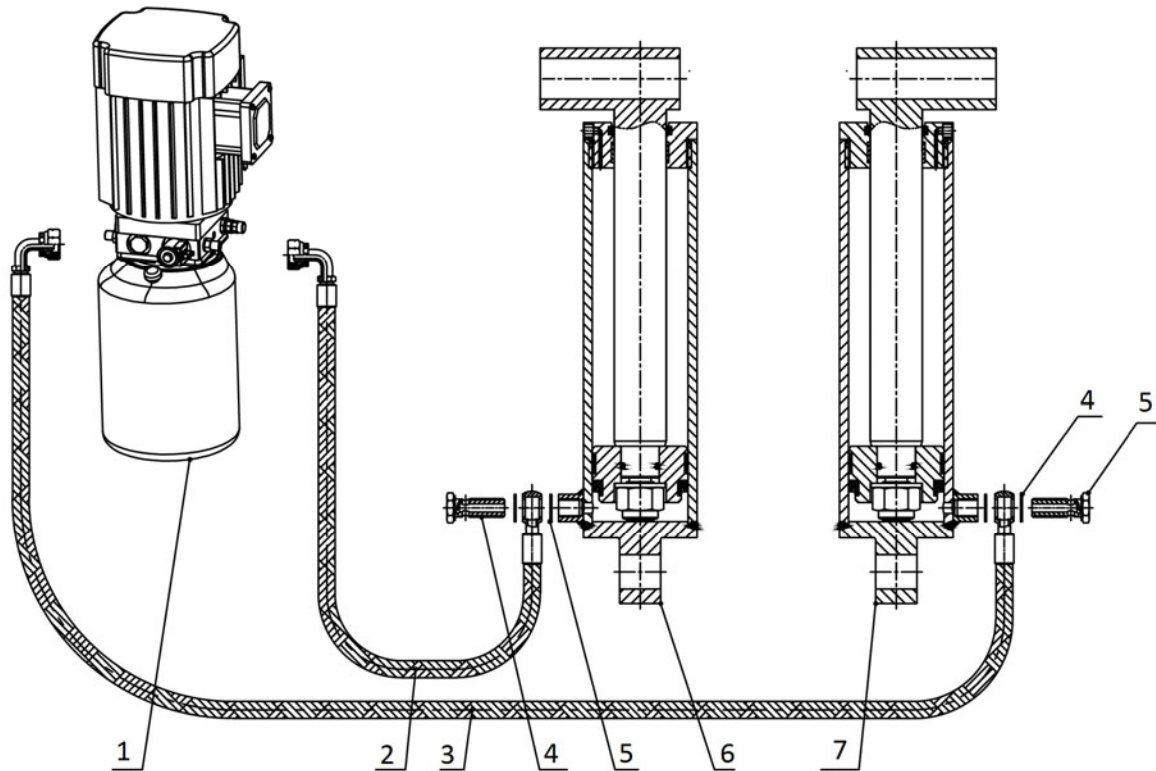

| Pos. | Code | Description | Specification | Qty |
|------|-----------|------------------------|-----------------------|-----|
| 1 | | Hydraulic power unit | 2.2kW | 1 |
| 2 | 624001862 | Rubber oil hose | L=3350mm (131 7/8") | 1 |
| 3 | 624001878 | Rubber oil hose | L=4770mm (187 13/16") | 1 |
| 4 | 410281130 | Oil cylinder connector | CJ-A12-B5-C10 | 2 |
| 5 | 207103025 | Composite washer | 13_7X20X1_5 | 4 |
| 6 | 615050001 | MR35 oil cylinder | MR35-A15-B1 | 1 |
| 7 | 615050002 | MR35 oil cylinder | MR35-A15-B2 | 1 |

Seal ring

| Cylinder CODE | Seal ring type | Seal ring code | Cylinder Specification | Qty |
|-------------------------|-----------------|----------------|------------------------|-----|
| 615050001/ 615050002 | Y Seal ring | 207102018 | B7-70*55*9 | 1 |
| | Y Seal ring | 207102030 | B7-70*60*6 | 1 |
| | Guiding ring | 207106031 | 70*66*15 | 1 |
| | Guiding ring | 207106032 | 38*42*15 | 1 |
| | Dust proof ring | 207105004 | BHS38*46*6 | 1 |

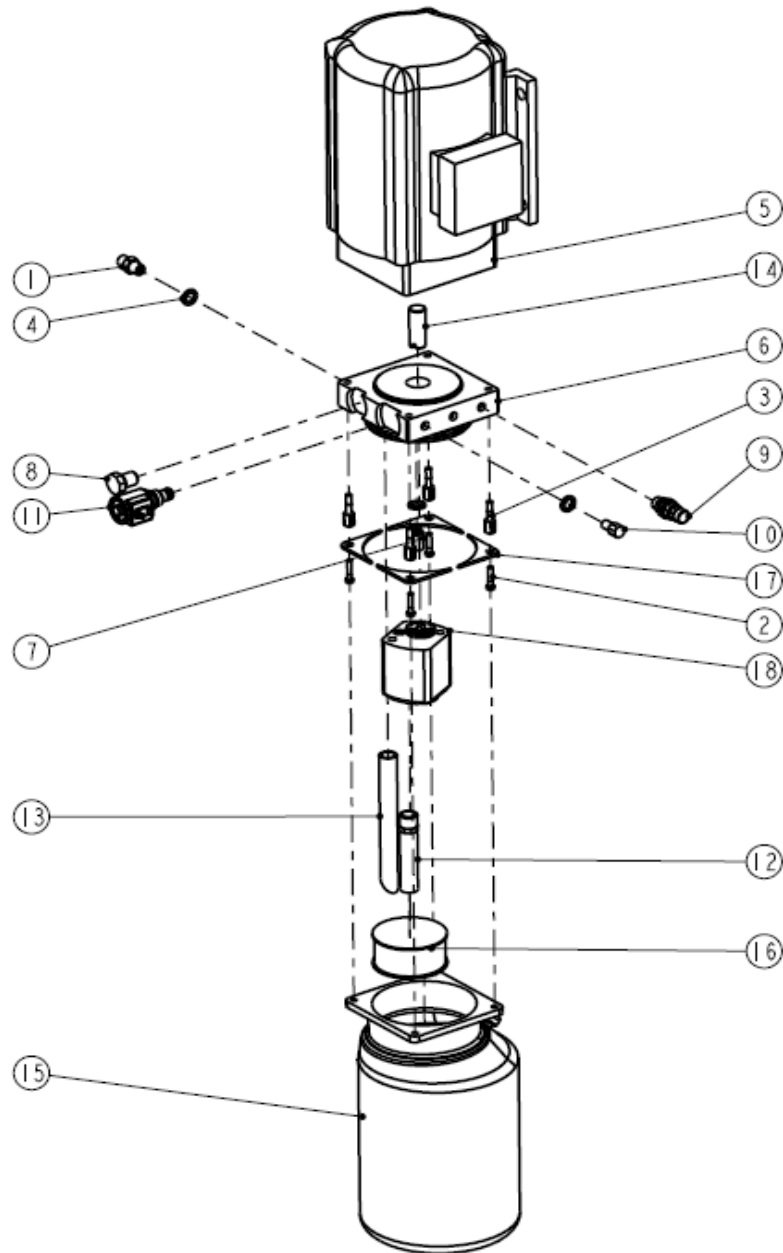

| Pos. | Code | Description | Specification | Qty |
|------|-----------|-----------------------------|-------------------------|-----|
| 1 | 310101008 | Connector | M14*1.5-G1/4inside cone | 1 |
| 2 | 201103001 | Hex flange screw | M5*25 | 4 |
| 3 | 202109064 | Oil tank installation screw | M6*30 | 4 |
| 4 | 207103025 | Composite washer | 13.7*20.00*1.50(BS224) | 3 |
| 5 | 320201294 | Motor | 110V-2.2KW -1PH-60HZ-2P | 1 |
| 5 | 320201011 | Motor | 220V-2.2KW -1PH-60HZ-2P | 1 |
| 6 | 330101005 | Hydraulic block (E) | YF-2D | 1 |
| 7 | 330301001 | Cushion valve | HZYF-C1 | 1 |
| 8 | 330302001 | Single valve | DYF-C | 1 |
| 9 | 330304001 | Overflow valve | EYF-C | 1 |
| 10 | 330305002 | Throttle valve | - | 1 |
| 11 | 330308006 | Solenoid unloading valve | DHF06-* | 1 |

| Pos. | Code | Description | Specification | Qty |
|------|-----------|-------------------------------|---------------|-----|
| 12 | 330401001 | Oil sucking tube | YX-BL=170 | 1 |
| 13 | 330402001 | Oil retuning tube | YH-D | 1 |
| 14 | 330404001 | Coupling | YL-A | 1 |
| 15 | 330405014 | Oil tank | 6L | 1 |
| 16 | 330403001 | Oil filter | YG-C | 1 |
| 17 | 410010091 | Reinforced plate for oil tank | 6254E-A4-B12 | 4 |
| 18 | 330201004 | Gear pump assembly | CBK-F216 | 1 |

NOTE: The motor is different for different voltage or capacity.

Please check with our customer service people when order spare parts.

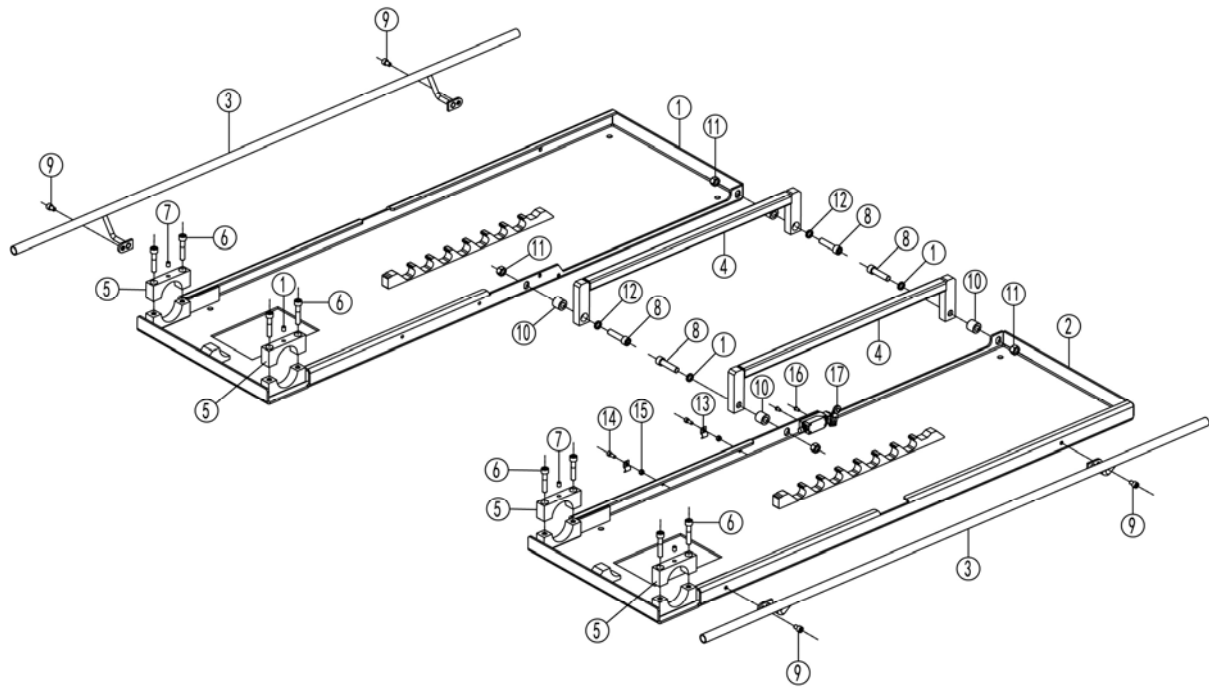
Annex 4, Mechanical exploded drawings and parts list

| Pos. | Code | Description | Specification | Qty |
|------|------------|--------------------------------|---------------|-----|
| 1 | 614901315 | Welded base frame assembly A | MR35-A01-B01 | 1 |
| 2 | 614901316 | Welded base frame assembly B | MR35-A02-B01 | 1 |
| 3 | 614018002 | Feet protection fender | MR30-A1-B7 | 2 |
| 4 | 614018018B | Connection bar | MR30-A26 | 2 |
| 5 | 410180013 | U block | MR30-A4 | 4 |
| 6 | 202109046 | Hex socket cylinder head screw | M10x50 | 8 |
| 7 | 208106002 | Oil cup | M8 | 4 |
| 8 | 202109081 | Hex socket cylinder head screw | M12X50-GB70 | 4 |
| 9 | 202109027 | Hex socket cylinder head screw | M8 x 12 | 4 |
| 10 | 410901876 | Spacer | MR30V2-A1-B14 | 4 |
| 11 | 203103008 | Hex locking nut | M12-GB889_1 | 4 |
| 12 | 204201006 | Spring washer | D12-GB93 | 4 |
| 13 | 206202005 | Air hose clip | D8-304 | 4 |
| 14 | 202109020 | Hex socket cylinder head screw | M6X15-GB70_1 | 4 |
| 15 | 203101004 | Hex nut | M6-GB6170 | 4 |
| 16 | 202101021 | Cross socket cap head screw | M5X10-GB818 | 2 |
| 17 | 320301011 | Limit switch | TZ-8108 | 1 |

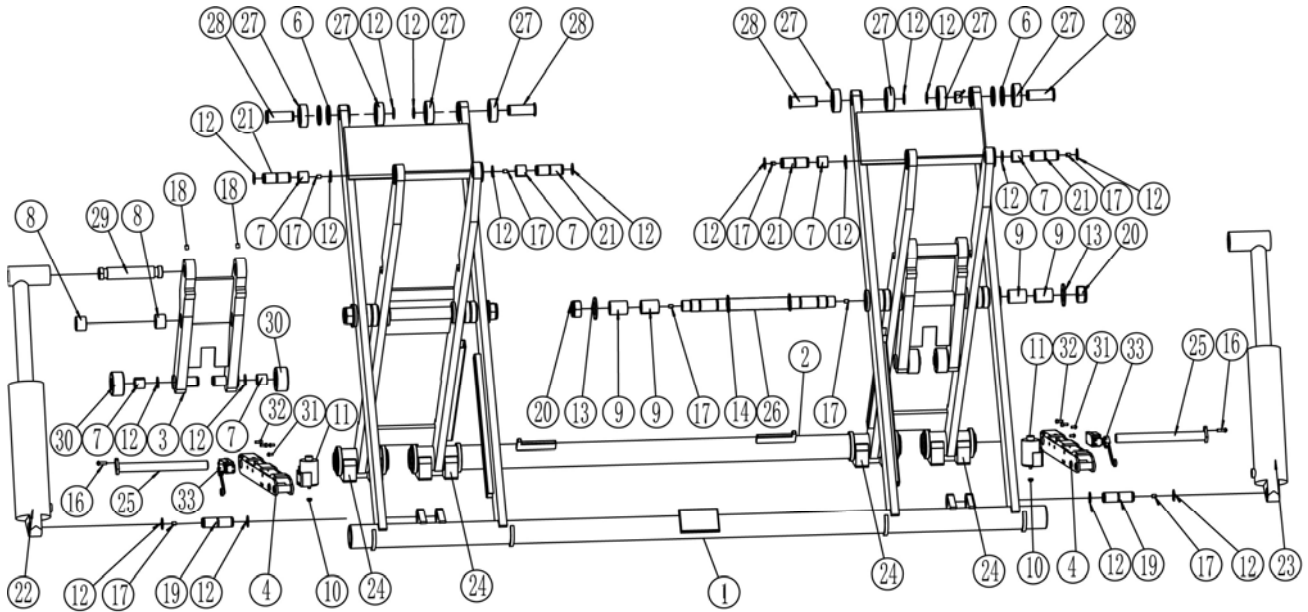

| Pos. | Code | Description | Specification | Qty |
|------|------------|-------------------------------|---------------|-----|
| 1 | 614050001B | Slave arm | MR35-A03-B01 | 1 |
| 2 | 614050002B | Drive arm | MR35-A03-B02 | 1 |
| 3 | 614050005 | Start plate | MR35-A08-B01 | 2 |
| 4 | 614901210 | Mechanical claw | MR35V2-A9-B1 | 2 |
| 6 | 204101012 | Flat washer | D24-GB95 | 8 |
| 7 | 205101010 | Bearing | 2525-SF-1 | 8 |
| 8 | 205101018 | Bearing | 3025-SF-1 | 4 |
| 9 | 205101022 | Bearing | 3045-SF-1 | 8 |
| 10 | 420180100 | Adjustable head | MR30E-A09-B03 | 2 |
| 11 | 330310018B | Electromagnet | DCT45X20 | 2 |
| 12 | 204301009 | Circlip | D25_GB894-2 | 20 |
| 13 | 204101014 | Flat washer | M27 | 4 |
| 14 | 204301011 | Circlip | D30-GB894_2 | 4 |
| 16 | 202101033 | Cross socket cap head screw | M6X20-GB818 | 2 |
| 17 | 208106002 | Oil cup M8 | M8-JB7940-4 | 14 |
| 18 | 202207002 | Hex socket tapping screw | M8X16-GB80 | 4 |
| 19 | 410180031C | Fixing shaft for oil cylinder | MR30-A16 | 2 |
| 20 | 203103013 | Self-locking nut | MR30-A18 | 4 |
| 21 | 410180051B | Platform fixing shaft | MR30-A21 | 4 |
| 22 | 615050002 | Cylinder 2 | MR35-A15-B2 | 1 |
| 23 | 615050001 | Cylinder 1 | MR35-A15-B1 | 1 |
| 24 | 420180040B | Slider | MR30-A5-B6 | 4 |
| 25 | 612018001 | Safety shaft | MR30-A5-B14 | 2 |
| 26 | 410500101B | X shaft | MR35-A03-B03 | 2 |
| 27 | 420180020B | UP rolling wheel | MR30-A8 | 8 |

| Pos. | Code | Description | Specification | Qty |
|------|-----------|--------------------------------|---------------|-----|
| 28 | 410180021 | Shaft of up rolling wheel | MR30-A9 | 4 |
| 29 | 410500241 | Cylinder shaft of start plate | MR35-A08-B02 | 2 |
| 30 | 410500271 | Start rolling wheel | MR35-A08-B03 | 4 |
| 31 | 202101021 | Cross socket cap head screw | M5X10 | 4 |
| 32 | 202109008 | Hex socket cylinder head screw | M5X12-GB70_1 | 4 |
| 33 | 320301011 | Limit switch (TZ8108) | TZ8108) | 2 |

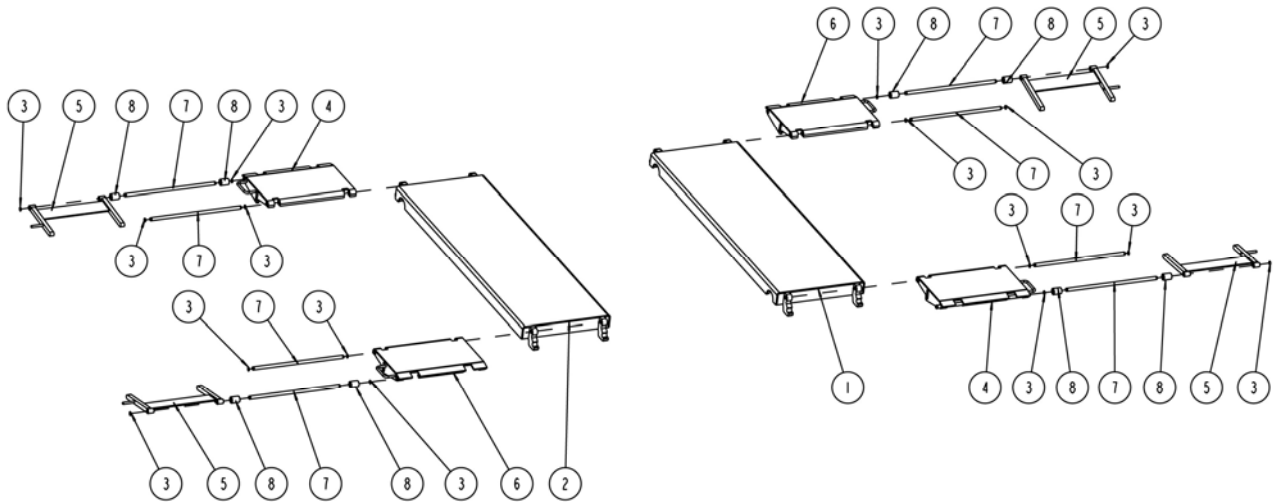

| Pos. | Code | Description | Specification | Qty |
|------|------------|---------------------|---------------|-----|
| 1 | 614901318 | Platform | MR35V2-A20 | 1 |
| 1 | 614901318 | Platform | MR35V2-A20 | 1 |
| 3 | 204301004 | Circlip $\phi 12$ | D15_GB894_2 | 16 |
| 4 | 614018011C | Ramp B assembly | MR30-A07-B01 | 2 |
| 5 | 614018010B | Supporting rod | MR30-A06-B02 | 2 |
| 6 | 614018009C | Ramp A assembly | MR30-A06-B01 | 2 |
| 7 | 410180061 | Shaft for the ramp | MR30-A22-B4 | 8 |
| 8 | 420180010 | Small rolling wheel | MR30-A22-B5 | 8 |

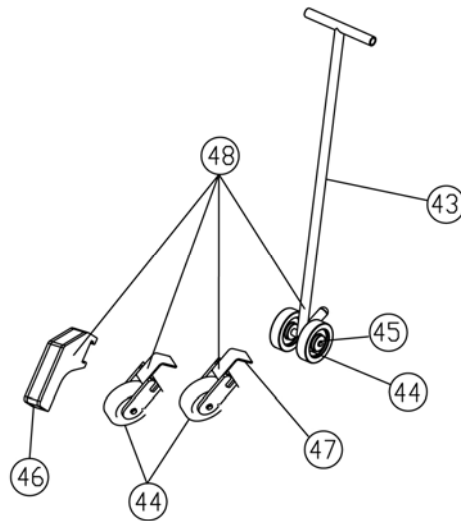
Optional mobile kit

| Pos. | Code | Description | Specification | Qty |
|------|-----------|---------------------------|-----------------|-----|
| 43 | 614018015 | All directional wheel kit | MR30-A25-B3 | 1 |
| 44 | 208107002 | Wheel | Rubber | 4 |
| 45 | 204301006 | Circlip D17 | Standard | 2 |
| 46 | 614018014 | Prop trough | MR30-A25-B2 | 1 |
| 47 | 410901747 | Wheel support kit | MR30-A25-B1-C1B | 2 |
| 48 | 615018006 | Mobile kit | Assembly | 1 |