

Model No. EE-6503V2

Short platform scissor lift

Electrical Levelling

With synchronization protection

Lifting capacity: 3500KG

Installation, Operation  
and Parts Manual



EAE

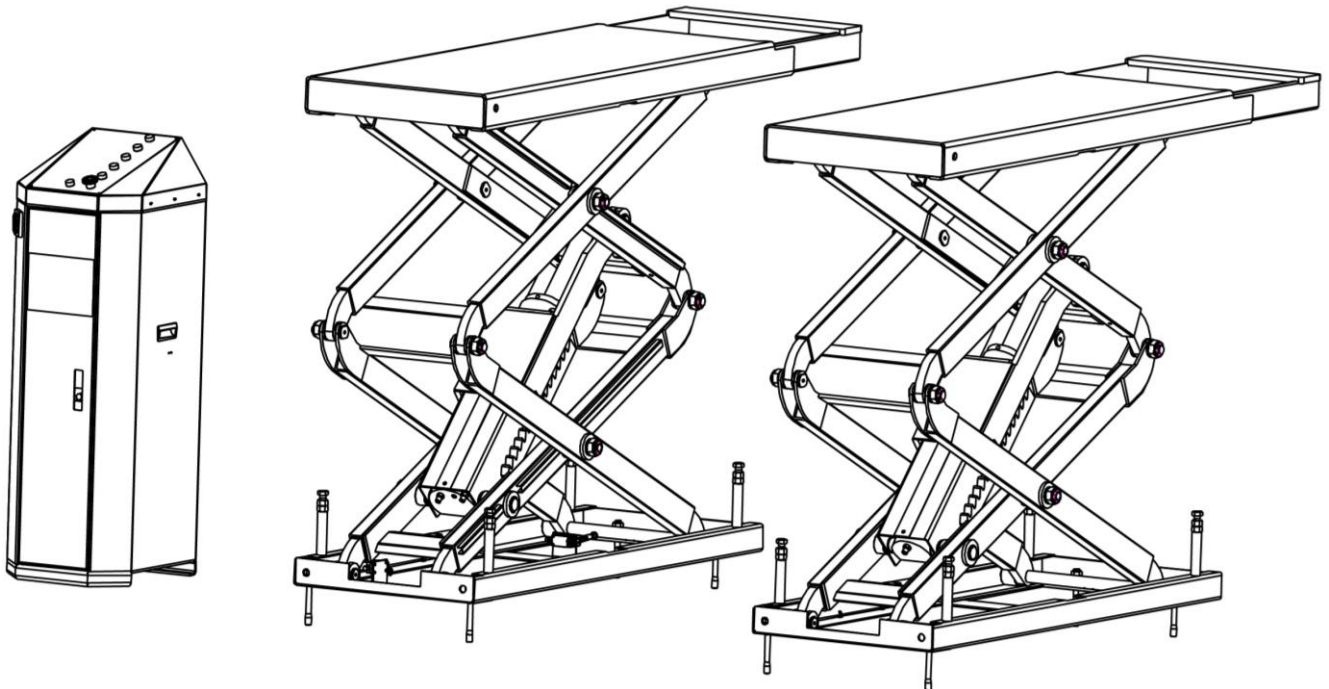

*Distributed by*

*Please read this entire manual carefully and completely before installation or operation of the lift.*

Date: 15/03/2024

[www.eae-ae.com](http://www.eae-ae.com)

## IMPORTANT NOTES

Before start up, connecting and operating EAE products, it is absolutely essential that the operating instructions/owner's manual and, in particular the safety instructions are studied carefully. By doing so you can eliminate any uncertainties in handling EAE products and thus associated safety risks up front; something which is in the interest of you own safety and will ultimately help avoid damage to the device, When an EAE product is handed over to another person, not only the operating instructions but also the safety instructions and information on its designated use must be handed over to the person.

By using the product you agree the following conditions:

### **Copy right**

The enclosed instructions are the property of EAE or its supplier, and are protected against duplication and reproduction by copyright laws, international agreements, and other domestic legislation. The reproduction or disclosure of instructions or an extract thereof is prohibited and offenders are liable to prosecution; EAE reserves the right or initiates criminal proceedings and asserts claims for damages in the event of infringements.

### **Warranty**

The use of non-approved hardware will result in a modification of our products and thus to the exclusion of any liability or warranty, even if such hardware has been removed again in the interim.

It is not permissible to make any changes to our products and these are not only to be used together with genuine accessories and genuine replacement parts. Otherwise any warranty claims will be invalid.

### **Liability**

The liability of EAE is limit to the amount that the customer has actually paid for this product. This exclusion of liability does not apply to damages caused through willful misconduct or gross negligence on the part of EAE.

**All information in this manual is believed to be correct at time of publication.**

**EAE reserves the right to amend and alter technical data and composition without prior notice.**

**Please confirm at time of ordering.**

<b>IMPORTANT NOTES .....</b>	<b>2</b>
<b>SAFETY NOTES .....</b>	<b>4</b>
1.1 Operation of lifting platforms .....	4
1.2 Checking of the lifting platforms .....	4
1.3 Important safety notices.....	5
1.4 Warning labels.....	6
1.5 Potential safety risks.....	7
1.6 Noise level .....	7
<b>PACKING, STORAGE AND TRANSPORTATION .....</b>	<b>8</b>
2.1 The lift was dismantled into the following 2 parts for transportation .....	8
2.2 Storage .....	8
2.3 Lifting and handling.....	8
<b>PRODUCT DESCRIPTIONS .....</b>	<b>9</b>
3.1 General descriptions.....	9
3.2 Construction of the lift.....	9
3.3 Dimensions .....	9
3.4 Safety devices descriptions.....	10
3.5 Technical data .....	10
<b>INSTALLATION INSTRUCTIONS .....</b>	<b>11</b>
4.1 Preparations before installation.....	11
4.2 Installation attentions .....	13
4.3 General Installation Steps .....	13
4.4 Items to be checked after installation. ....	16
<b>OPERATION INSTRUCTIONS .....</b>	<b>16</b>
5.1 Precautions.....	16
5.2 Operation instructions.....	17
5.3 Flow chart for operation.....	17
5.4 Operation instructions.....	18
5.5 Emergency lowering.....	19
<b>TROUBLE SHOOTING.....</b>	<b>20</b>
<b>MAINTENANCE .....</b>	<b>21</b>
Annex 1, Electrical diagrams and parts list .....	23
Annex 2, Hydraulic diagrams and parts list.....	27
Annex 3, Pneumatic diagrams and parts list.....	31
Annex 4, Mechanically exploded drawings and parts list .....	32

# SAFETY NOTES

## 1.1 Operation of lifting platforms

This lift is specially designed for lifting motor vehicles. Users are not allowed to use it for any other purposes. The applicable national regulations, laws and directives must be observed.

Only users aged 18 or above who have been instructed on how to operate the lifting platform and have proven their ability to do so to the owner are to be entrusted with unsupervised operation of lifting platforms. The task of operating the lifting platforms must be granted in writing.

Before loading a vehicle onto the lifting platform, users should study the original operation instructions and familiarize themselves with the operating procedures in several trial runs.

**Lift vehicle within the rated load. Don't attempt to raise vehicles with excessive weight.**

## 1.2 Checking of the lifting platforms

Checks are to be based on the following directives and regulations:

- Basic principles for testing lifting platforms
- The basic health and safety requirements stipulated in the directive 2006/42/EC
- Harmonized European standards
- The applicable accident prevention regulations

The checks are to be organized by the user of the lifting platform. The user is responsible for appointing an expert or qualified person to perform checking. It must be ensured that the person chosen satisfies the requirements.

The user bears special responsibility if employees of the company are appointed as experts or qualified persons.

### 1.2.1 Scope of checking

Regular checking essentially involves performing a visual inspection and a functional test. This includes checking the condition of the components and equipment, checking that the safety systems are complete and functioning properly and that the inspection log book is completely filled in. The scope of exceptional checking depends on the nature and extent of any structural modification or repair work.

### 1.2.2 Regular checking

After initial commissioning, lifting platforms are to be checked by a qualified person at intervals of not longer than one year.

**A qualified person** is somebody with the training and experience required to possess sufficient knowledge of lifting platforms and who is sufficiently familiar with the pertinent national regulations, accident prevention regulations and generally acknowledged rules of engineering to be able to assess the safe operating condition of lifting platforms.

### 1.2.3 Exceptional checking

Lifting platforms with a lift height of more than 2 meters and lifting platforms intended for use with people standing under the load bearing elements of the load are to be checked by an expert prior or reuse following structural modifications and major repairs to load bearing components.

**An expert** is somebody with the training and experience required to possess specialist knowledge of lifting platforms and who is sufficiently familiar with the pertinent national work safety regulations, accident prevention regulations and generally acknowledged rules of engineering to be able to check and give an expert option on lifting platforms.

### 1.3 Important safety notices

1.3.1 Recommend for indoor use only. DO not expose the lift to rain, snow or excessive moisture.

1.3.2 Only use this lift on a surface that is stable, level and dry and not slippery, and capable of sustaining the load. Do not install the lift on any asphalt surface.

1.3.3 Read and understand all safety warnings before operating the lift.

1.3.4 Do not leave the controls while the lift is still in motion.

1.3.5 Keep hands and feet away from any moving parts. Keep feet clear of the lift when lowering.

1.3.6 Only these properly trained personnel can operate the lift.

1.3.7 Do not wear unfit clothes such as large clothes with flounces, tires, etc., which could be caught by moving parts of the lift.

1.3.8 To prevent evitable incidents, surrounding areas of the lift must be tidy and with nothing unconcerned.

1.3.9 The lift is simply designed to lift the entire body of vehicles, with its maximum weight within the lifting capacity.

1.3.10 Never remove safety related components from the lift. Do not use if safety related components are damaged or missing.

1.3.11 Do not rock the vehicle while on the lift or remove any heavy component from vehicle that may cause excessive weight shift.

1.3.12 Check at any time the parts of the lift to ensure the agility of moving parts and the performance of synchronization. Ensure regular maintenance and if anything abnormal occurs, stop using the lift immediately and contact our dealers for help.

1.3.13 Lower the lift to its lowest position and do remember to cut off the power source when service finishes.

1.3.14 Do not modify any parts of the lift without manufacturer's advice.

1.3.15 If the lift is going to be left unused for a long time, users are required to:

- a. Disconnect the power;
- b. Empty the oil tank;
- c. Lubricate the moving parts with hydraulic oil.

**WARNING:** The warnings, cautions and instructions discussed in this instruction manual cannot cover all possible conditions and situations that may occur. It must be understood by the operator that common sense and caution are factors which cannot be built into this product, but must be supplied by the operator.







**Attention:** For environment protection, please dispose the disused oil in a proper way.

### 1.4 Warning labels

All safety warning labels are clearly depicted on the lift to ensure that the operator is aware of and avoid the dangers of using the lift in an incorrect manner. The labels must be kept clean and they have to be replaced if detached or damaged. Please read carefully the meaning of each label and memories them for future operation.

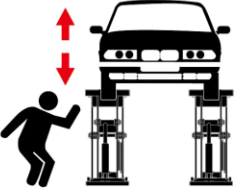
## SAFETY ADVICE

540101634

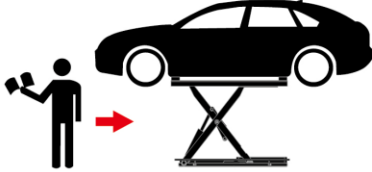
 <p>Only trained personnel are allowed to operate the lift.</p>	<p>Always keep lift area clear when lowering or raising vehicle.</p> 
 <p>Do not try to raise a vehicle exceeds the rated capacity.</p>	<p>Never raise or lower a vehicle with one side platform.</p> 
 <p>Watch closely the vehicle during raising or lowering.</p>	<p>Make sure vehicle is neither front nor rear heavy and center of balance should be centered over the lift.</p> 
 <p>Make sure that two platforms are of equal height from the floor when safety teeth engaged.</p>	<p>Avoid excessive rocking of vehicle while on lift.</p> 
 <p>Do not climb onto the lift platforms or raised vehicle during lifting or lowering.</p>	<p>Always keep the lift pit clean and clear of any objects or contaminants.</p> 
 <p>Do not change the safety mechanism.</p>	<p>Carryout maintenance regularly as indicated in the manual.</p> 

**EAE**
www.eae-ae.com

Copyright © EAE Automotive Equipment Company Limited, All rights reserved.

## 1.5 Potential safety risks

### 1.5.1 Mains voltage



Insulation damage and other faults may result in accessible components being live

Safety measures:

- Only ever use the power cord provided or a tested power cord.
- Replace wires with damaged insulation.
- Do not open the operating unit.

### 1.5.2 Risk of injury, danger of crushing



In the event of excessive vehicle weight, incorrect mounting of the vehicle or on removing heavy object, there is a risk of the vehicle falling off the lifting platform or tipping up.

Safety measures:

- The lifting platform is only ever to be employed for the intended purpose.
- Carefully study and heed all the information given in Section 1.4.
- Observe the warning notices for operation.

## 1.6 Noise level

Noise emitted during operating the lift should be less than 70dB. For your health consideration, it is suggested to place a noise detector in your working area.

# PACKING, STORAGE AND TRANSPORTATION

Packing, lifting, handling, transporting operations must be performed only by experienced personnel with appropriate knowledge of the lift and after reading this manual.

## 2.1 The lift was dismantled into the following 2 parts for transportation

Name	Packed by	Dimension(mm)	Weight(kg)	Quantity
Control cabinet	Wooden case	500*470*1020	80	1
Lift platform	Carton with wooden base	1700*600*950	657	1

## 2.2 Storage

The packs must be kept in a covered and protected area in a temperature range of  $-10^{\circ}\text{C}$  to  $+40^{\circ}\text{C}$ . They must not be exposed to direct sunlight, rain or water.

### Stacking the packs

We advise against stacking because the packs are not designed for this type of storage. The narrow base, heavy weight and large size of the packs make stacking difficult and potentially dangerous.

If stacking is unavoidable, use all appropriate precautions:

-never stack to more than 2 meters in height.

-never make stacks of single packs. Always stack pairs of packs in a cross pattern so that the base is bigger and the resulting stack is more stable. Once the stack is complete, restrain it using straps, ropes or other suitable methods.

A maximum of two packs can be stacked on lorries, in containers, and in railway wagons, on condition that the packs are strapped together and restrained to stop them falling.

## 2.3 Lifting and handling

The packs can be lifted and transported only by using lift trucks.

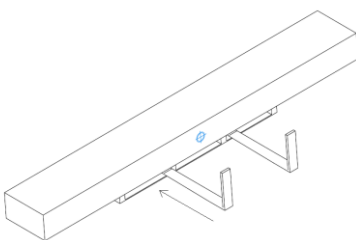

### Opening the packs

When the lift is delivered make sure that it has not been damaged during transportation and that all the parts specified on the packing list are present.

Packs must be opened adopting all the precautions required to avoid injury to persons (keep at a safe distance when cutting the straps) or damage to parts of the machine (be careful that no parts are dropped while you are opening the packing)

**Take special care with the hydraulic power unit, the control panel and the platform cylinder.**



# PRODUCT DESCRIPTIONS

## 3.1 General descriptions

This model is chassis supporting vehicle lift for road vehicles. It is designed for recessed mounting and is composed by two lifting platforms and a set of power unit. The gear pump works to make oil in the pump push upwards the pistons of oil cylinders. Meanwhile support scissor brackets of the lift rise accordingly. In the process of rising, the independent mechanical safety locking system protects the lift from slipping in case of hydraulic failure. Besides, safety designs like 24V working voltage of control box and limit switch, low-height alarming buzzer, anti-surge valves have fully considered your personal security.

## 3.2 Construction of the lift

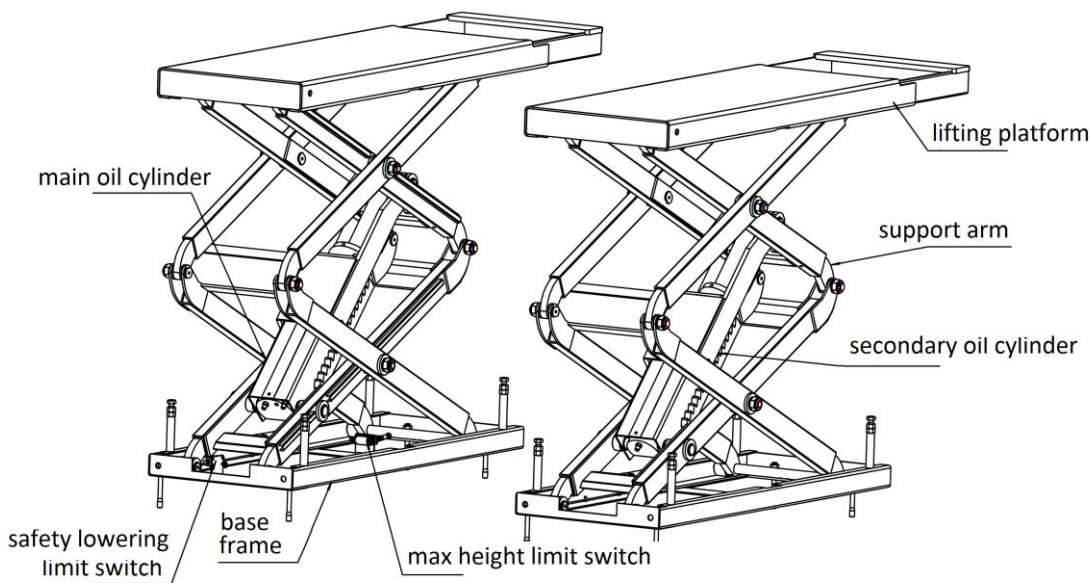

## 3.3 Dimensions

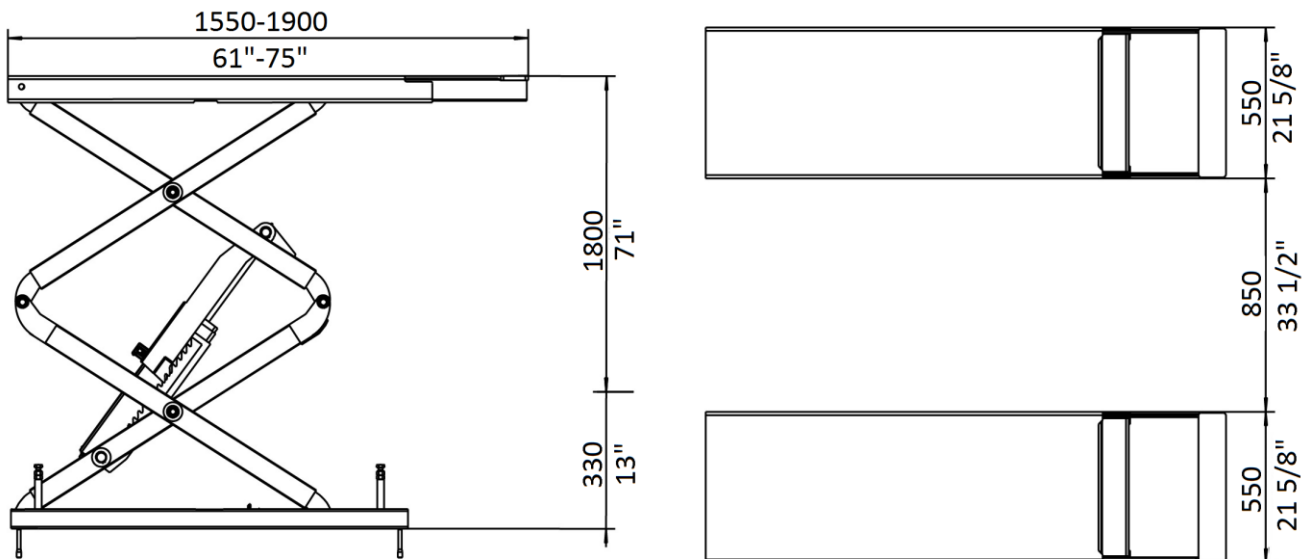

### 3.4 Safety devices descriptions

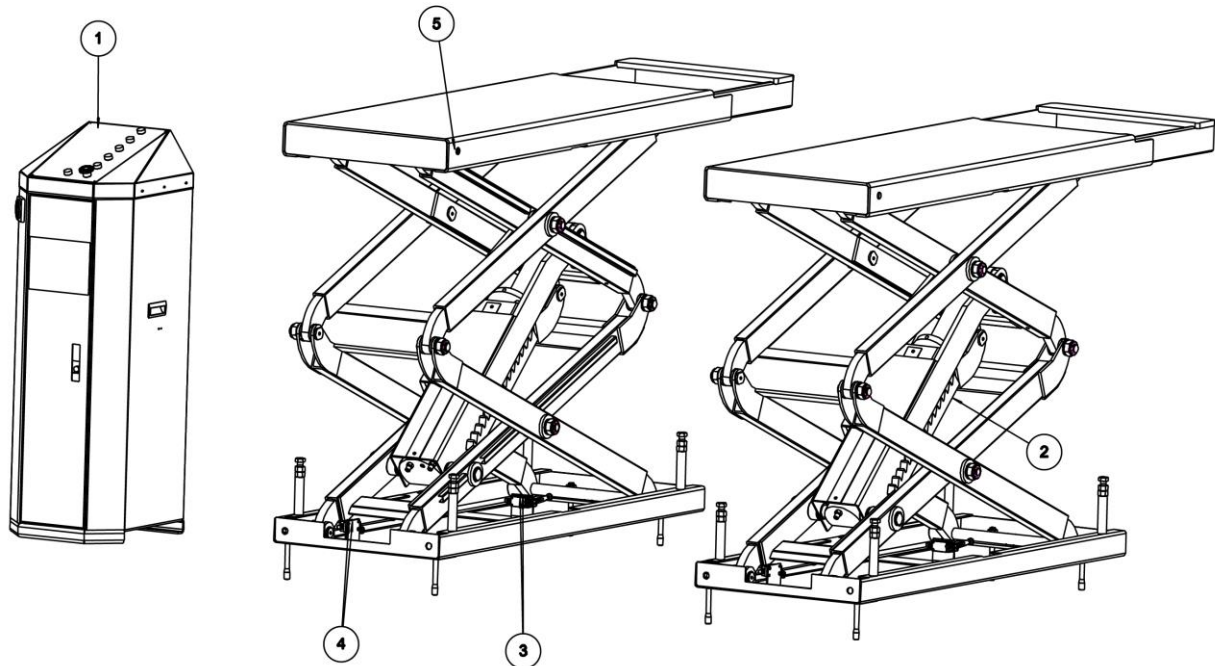

POS.	Safety device	Function
1	24V operation voltage	Safety voltage for operators.
2	Mechanical locking unit	Protect the lifting platform from descending dangerously in case of hydraulic failure.
3	Max height limit switch	Stop raising once the rated maximum height is reached.
4	Safe lowering height limit switch	The lifting platforms stop lowering at a safety height above the ground. Push DOWN II button to continue the lowering movement, which accompanies with acoustic buzz warning service persons being away from the moving parts.
5	Synchronization protection device	Disconnect operation power in case unacceptable desynchronization occurs so as to prevent incidents caused by unintended desynchronization.

### 3.5 Technical data

Rated load capacity	3500kg
Full rise height	1800mm
Full lowered height	330mm
Full rise time with load	≤60s
Full lowering time with load	≤30s
Hydraulic pressure	22-24MPa
Pneumatic pressure	6-8 bar
Oil Volume	10L

# INSTALLATION INSTRUCTIONS

## 4.1 Preparations before installation

### 4.1.1 Space requirements.

Refer to 3.3 for the dimensions of the lift. There must also be a clearance of at least 1 meter between the lifting platform and fixed elements (e.g. wall) in all lifting positions. There must be sufficient space at the ends of the lifting platform for driving vehicles on and off.

**To stop vehicles colliding with the ceiling, it is advisable to fit an overhead light barrier in low ceiling buildings.**

### 4.1.2 Foundations and connections

The user must have the following work performed before erecting the lift.

- Construction of the foundation following consultation with the manufacturer's customer service or an authorized service agent.
- Routing of the wiring to the installation location. Refer also to the corresponding information on the name plate and in the operation instructions. Before doing electrical connection, make sure the lift is electrically adapt to the local power supply.
- The user must provide fuse protection for the connection. Requirements for power supply cable of the installation site: at least 2.5mm<sup>2</sup> wire core for 3Ph power and 4.0mm<sup>2</sup> wire core for 1Ph power. *Attention: electrical system connection must be done by licensed technicians.*
- Routing of the compressed air connection to the installation location.

### 4.1.3 Foundations preparations

#### Indoor installation only.

There must also be a clearance of at least 1 meter between the lifting platform and fixed elements (e.g. wall) in all lifting positions. There must be sufficient space for driving vehicles on and off.

C25/30 concrete foundation with a minimum thickness of 150mm.

Surface: Horizontal and even (Gradients max. 0.5 %)

Embed L40 angle iron around the pit for edging (optional);

Reserve a water collection pit in the case drain pipes are not available;

Newly built concrete foundation must be older than 20days.

In mm.

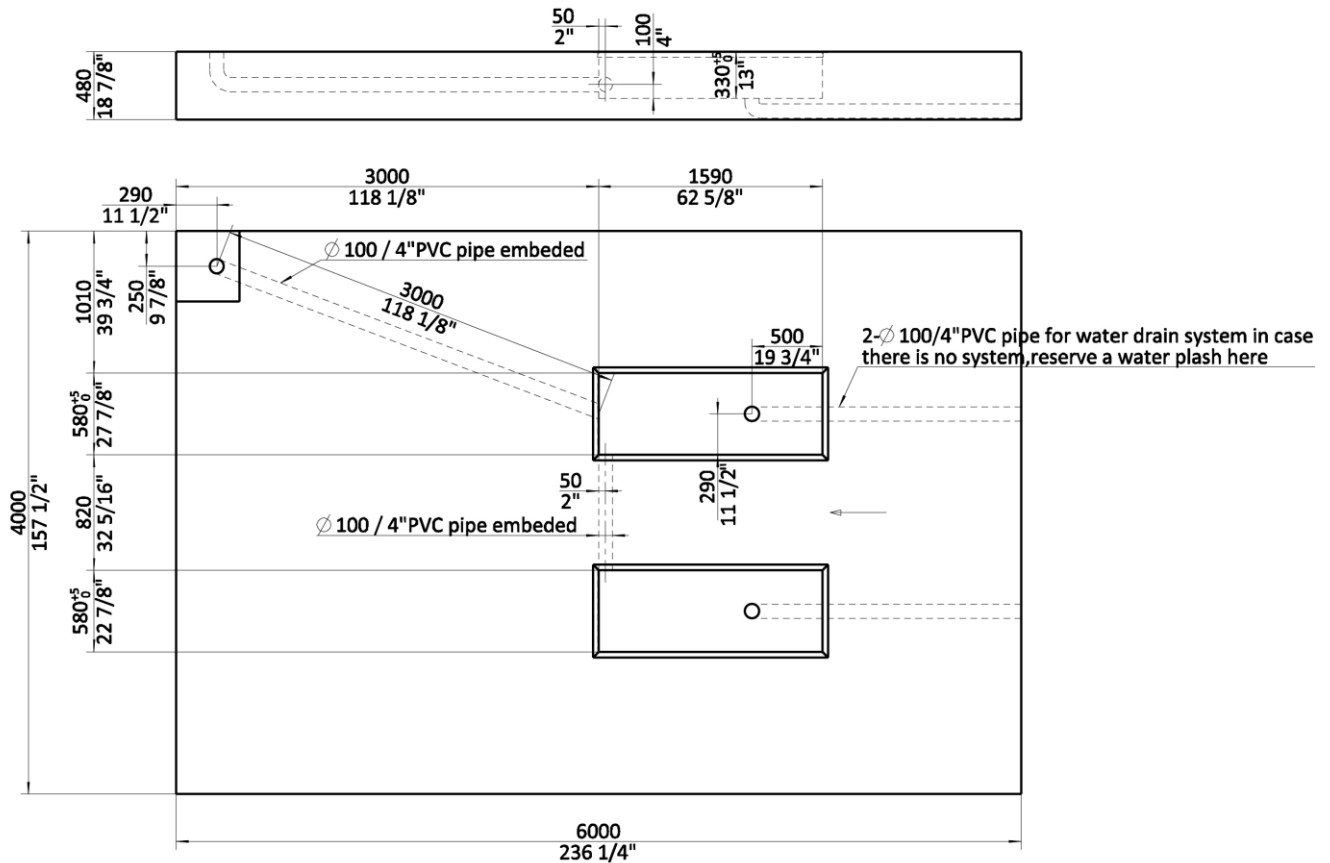

#### 4.1.4 Tools and equipment needed for installation

Tool name	Specification	Quantity
Electrical drill	With D16 and D18 drill bit.	1
Open spanner	D17-19mm	2
Adjustable spanner	bigger than D30mm	1
Cross socket screw driver	PH2	1
Quick spanner handle adapter/ Ratchet		1
Socket spanner	D24mm	1
Levelling device		1
Hammer	10 pounds	1
Truck lift	Capacity,1000 kg	1
Lifting strap	Capacity,1000 kg	2

#### 4.1.5 Checking parts

Unfold the package and check if any parts missed as per the following list. Do not hesitate to contact us in case any parts missed, but if you do not contact us and insist installing upon the lack of some parts, we as well as our dealers will not bear any responsibility for this and will charge for any parts subsequently demanded by the buyer.

Control cabinet		
No.	Name	Qty
1	6503V2 control cabinet	1
2	Rubber pad	4
3	Expansion bolt	8
4	Air hose	2m
5	Manual	1
6	Key	1
7	Oil tank label	1
Lifting platforms		
No.	Name	Qty
1	6503V2 -main platform	1
2	6503V2-secondary platform	1

#### 4.2 Installation attentions

4.2.1 Joints of oil hose and wiring must be firmly connected in order to avoid leakage of oil hose and looseness of electrical wires.

4.2.2 All bolts should be firmly screwed up.

4.2.3 Do not place any vehicle on the lift in the case of trial running.

#### 4.3 General Installation Steps

##### Step 1: Dismantle the package of the lifting platforms.

Remove the carton and packing films wrapped on the platform.

**WARNING! : Take off oil hose protectors when cut off the packing strips.**

**WARNING! : Avoid scratching the painting surface and hoses.**

##### Step 2: Place the lifting platform at expected installation site.

Raise the platform by using a forklift and 2 lifting strings until the mechanical lock is engaged. And then hoist the platform onto the expected installation site. Dismantle the bolts that fix the platform and its wooden package and move it to the installation site in the same way as the upper platform.

**Attention 1: Before hoisting, make sure the hoses and wires are well protected against damage.**

**Attention 2: It is necessary to hold the platform during the hoisting process. Irrelevant person is not allowed in installation area.**

##### Step 3: Open the package of the control cabinet and take out accessories in it.

**Step 4: Connect hydraulic oil hoses.**

Refer to Annex 2. Screw torque for oil hose connector is 60N\*m.

Firstly, connect the oil hoses between the two platforms. There are 3 oil hoses together. And then, connect the 2 oil hoses from the main platform with the tie-ins remained on the hydraulic block in the control cabinet. Oil hoses go into the cabinet through the holes remained at the bottom of the cabinet.

*Attention: Connect as per the marks on the hoses and do not contaminate the hydraulic components during the connection.*

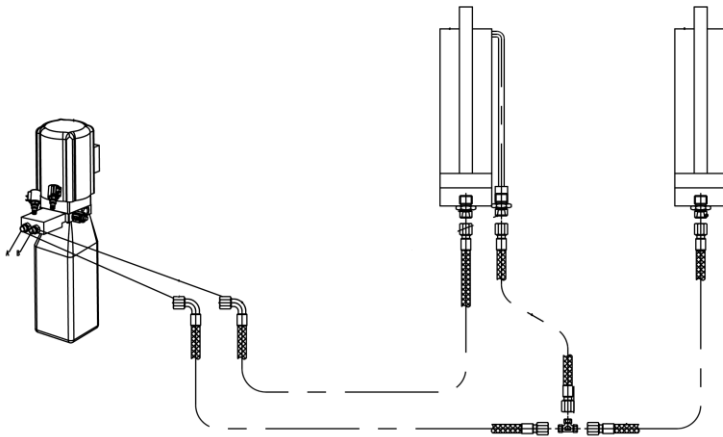
**Step 5: Connect the electrical system.**

Refer to Annex 1 when fix the electrical system.

Connect the wire connectors for rising and lowering limit switches

Connect the power supplier cable to external electricity supply.

*(For three phase power supply, if the lift doesn't raise and the motor may turn in the wrong direction, in such event, interchange wires U, V in the control cabinet).*

**Step 6: Connect the pneumatic release system.**

Refer to Annex 3.

Screw torque for pneumatic hose connector is 20Nm.

External compressed air shall be prepared by the end user before installation.

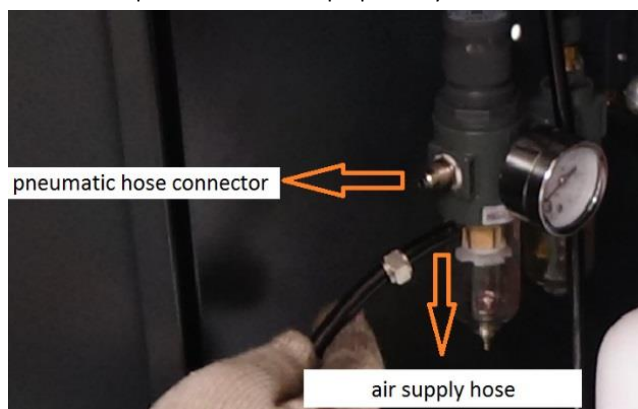

Set the pneumatic pressure between 6-8 bars.

Push upward the button indicated in the following fig and turn the button until the hand of the pressure meter points to the NUMBER "6".

Push the button down thereafter.



It is suggested to add ISO VG32 mechanical oil into the oil tank.

Adjust the oil dripping quantity using the button on top of the oil cup.



### Step 7: Fill with hydraulic oil.

**CLEAN AND FRESH OIL ONLY. DON'T FILL THE TANK COMPLETELY FULL.**

**Lift must be fully lowered before changing or adding hydraulic oil**

Pour 10 liters anti-abrasion hydraulic oil into the oil tank. The level of oil shall reach the tippets volume mark of the tank.

Add more oil after running the lift for several cycles until the lift can rise to the maximum lifting height.

**Note:** It is suggested to use HM NO.46 hydraulic oil. Use NO.32 hydraulic oil when average temperature of the location is below 10 degree Celsius.

**Change the oil 6 months after initial use and change once per year thereafter.**

### Step 8: Levelling

**Check the connection of the hydraulic and electrical system before levelling operation**

**Review operation instructions and get familiar with lift controls by running the lift through a few cycles before levelling operation.**

**WARNING! : Level the platforms before connecting max height limit switch because if not, platforms may not rise to the highest position.**

**The operator needs to know clear which levelling valve controls which platform. This could be judged by the way that the oil hose was connected or by trial raising or lowering.**

**Turn the selection switch SA2 to "off" mode before levelling operation.**

1. Connect the power supply and turn on the main power switch on the control panel.
2. Push the "UP" button for 30 seconds. Normally at least one of the platforms will rise at this moment.

*(For three phase power supply, if the lift doesn't raise and the motor may turn in the wrong direction, in such event, interchange wires U, V).*

3. Turn the selection switch in the control box to "levelling" mode then push the "UP" or "DOWN" button to adjust the height of the secondary platform until it reaches to the same height as that of the main platform. Turn the selection switch in the control box to "working" mode and push the "UP" and "DOWN" button to check the synchronization of the two platforms. If synchronization is not achieved, repeat the above levelling steps until synchronization reached.

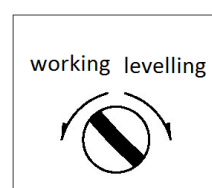

**Step 9: Fix base frames with expansion bolts.**

Screw torque of the bolts : 60 -80Nm;

1. Adjust the distance between the two lifting platforms and mark the points for each anchoring bolt.
2. Drill anchor holes with an electrical drill. Make sure to drill vertically.
3. Remove thoroughly the debris and dust in holes and hammer in and secure with expansion bolts.

**4.4 Items to be checked after installation.**

S/N	Check items	YES	NO
1	Screw torque of expansion bolts : 60 -80Nm;		
2	Rising speed $\geq 20$ mm/s;		
3	Noise with rated load $\leq 75$ dB;		
4	Grounding resistance: not bigger than $4\Omega$ ;		
5	Height difference of the two platform $\leq 5$ mm;		
6	Mechanical locks are robust and synchronized when running with rated load ;		
7	If the control button works as "hold to run"?		
8	If limit switches work well?		
9	If grounding wire is connected?		
10	If rising and lowering smoothly?		
11	If there is no abnormal notice during running with rated load?		
12	If there is no oil leakage when running with rated load?		
13	If there is no air leakage when running with rated load?		
14	If expansion bolts, nuts or circlips is well secured?		
15	If max lifting height is 1800mm (above ground)?		
16	If Safety advices, name plate and logos are clear?		

## OPERATION INSTRUCTIONS

### 5.1 Precautions

- 5.1.1 Read and digest the complete operation instructions before operating the lift.
- 5.1.2 Only authorized persons are permitted to operate the lift.
- 5.1.3 Do not try to raise the vehicle with excessive length or width.
- 5.1.4 The space above and below the load as well as of the loading carrying devices shall be free of obstructions.
- 5.1.5 Position supporting pads to pick-up positions recommended by vehicle manufacturers.
- 5.1.6 Check the vehicle after raising a short distance to ensure that it is corrected and safely positioned.
- 5.1.7 The load carrying device shall be observed by the operator throughout the motion of the lift.
- 5.1.8 Engage the safety locking mechanism before entering under the raised vehicle.
- 5.1.9 Always use safety stands before removing and installing heavy component which may cause uneven load distribution.
- 5.1.10 Avoid excessive rocking of vehicle while on the lift
- 5.1.11 It is forbidden for people to stand in the field of motion during raising or lowering movement.
- 5.1.12 Do not climb onto the load or load carrying device when they are raised.



### 5.2 Operation instructions

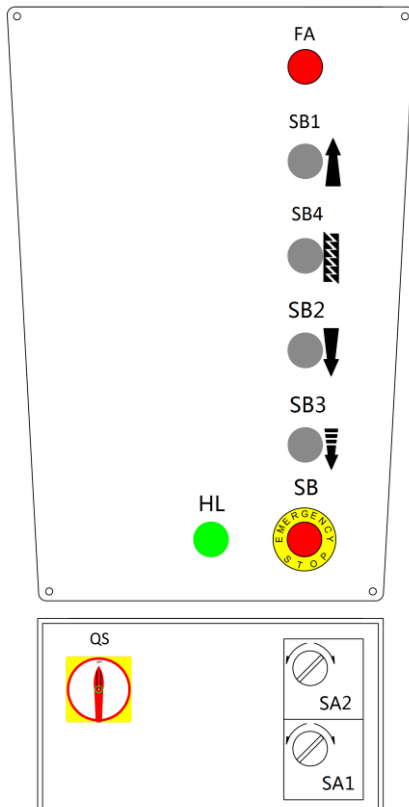

Pos.	Name	Function
FA	Alarm buzzer	Acoustic warning
SB1	UP button	Control the rising movement
SB4	Lock button	Engage the mechanical locking unit
SB2	DOWN I button	Control the lowering movement
SB3	DOWN II button	Control the lowering movement (for lowering safety )
SB	Emergency stop	Disconnect operation power in emergency case
HL	Power indicator	Show if electricity is connected
QS	Power switch	Control main power
SA1	Selection switch	Select working or levelling mode
SA2	Selection switch	Select synchronization protection device on or off mode

### 5.3 Flow chart for operation

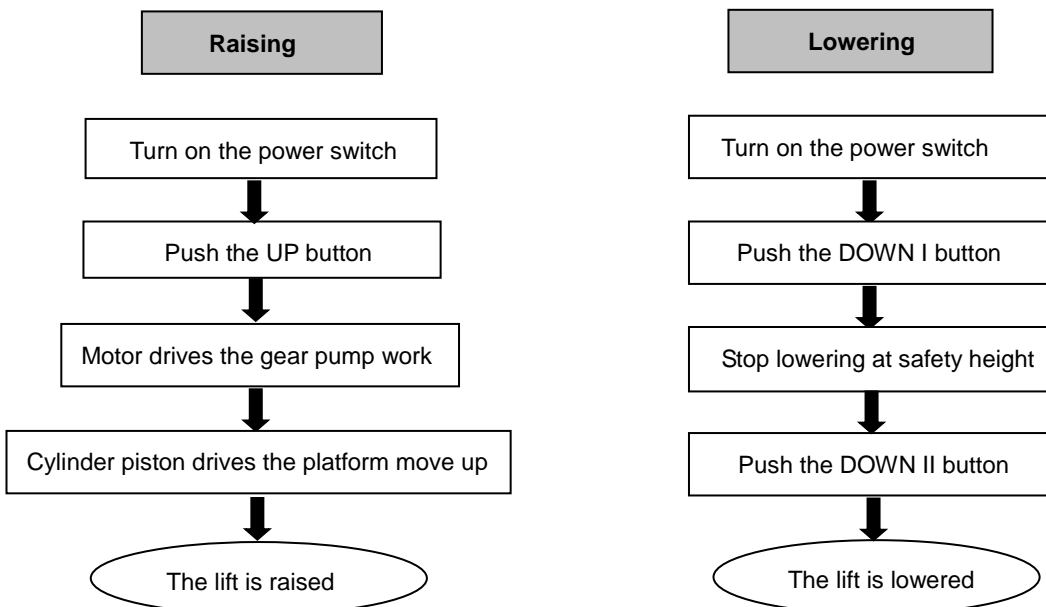

## 5.4 Operation instructions

To avoid personal injury and/or property damage, permit only trained personnel to operate the lift.

After reviewing these instructions, get familiar with lift controls by running the lift through a few cycles before loading vehicle on lift. Always lift the vehicle using all four adapters. Never raise just one end, one corner or one side of vehicle.

The lift must be only used in a static position for lifting and lowering vehicles.

Turn SA1 to WORKING and SA2 to ON mode before normal use. \

The normal users are not allowed to open the door of control cabinet.

### **Raise the lift**

Make sure vehicle is neither front nor rear heavy and center of balance should be midway between adapters and centered over the lift.

1. Make sure that you have read and understood the operation manual before operation.
2. Load vehicle on lift carefully. Position the lift adapters to contact at the vehicle manufacturer's recommended lift points.
3. Push the UP button to raise lift until adapters contact vehicle.
4. Check adapters for secure contact with vehicle. Raise the lift to expected working height.

### **Lower the lift**

When lowering the lift pay careful attention that all personnel and objects are kept clear.

1. Push the DOWN I button to lower the lifting platform. It will stop lowering at safety height.
2. Push DOWN II button to continue lowering the platforms which accompanies with safety alarming buzz.
3. After the lifting platform is fully lowered, remove rubber pads and other tools to provide an unobstructed exit for moving vehicle from the lift area.
4. Drive the vehicle away.

**Attention: In the case the desynchronisation of the two platforms are unacceptable (about 6CM difference) during lifting or lowering process, the synchronization protection device will be activated to stop any raising or lowering movement. In this case the normal operator needs to ask professional help from maintenance operator to restore the lift to normal working condition.**

### **Restore to the normal working status.**

Open the door of the control cabinet;

Turn SA1 to OFF mode;

PUSH DOWN I and DOWN II button to fully lower the platform;

Level the lift until both platform are synchronized. (Refer to Step 8: Levelling)

Turn SA1 to ON mode.

## 5.5 Emergency lowering

Emergency situation means: 1. Electricity power failure 2. Failure on equipment itself

**Suitable condition:** Compressed air is available.

Normally, in case of sudden electricity power failure, the compressed air remained can still make the pneumatic system of the lift work.

**In the case the mechanical safety locks are not engaged, follow the following steps for emergency lowering.**

**Attention:** Pay careful attention as there could be potential hazards in doing so.

1. Open the control cabinet and find out the manually controlled air-supplying button and emergency unloading solenoid valve.



2. Take off the protective cap of the valve and see red spool of the valve.

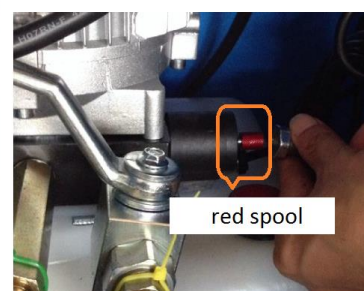

3. Push the blue air-supplying button and meanwhile push and turn anticlockwise the red spool until hear sound which implicate the valve is open. At this time, lifting platforms may lower.

**Attention:** when do the above operation, operators need to focus on the lowering platform.

**If any abnormal occurs, stop pushing the blue air-supplying button and push and turn clockwise the red spool until hear the sound which implicate the valve is closed.**

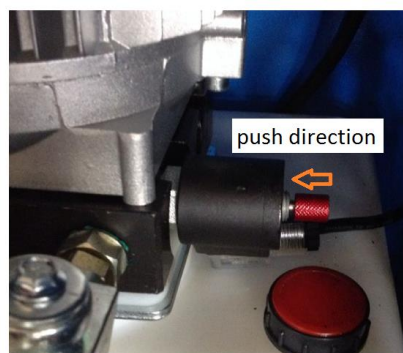

4. Turn off the unloading valve by pushing and turning clockwise the red spool until hear the sound which implicate the valve is closed.

**NOTE:** For different models, the pictures showing above may differ from lift to lift, but the methods is the same.

## TROUBLE SHOOTING

ATTENTION: If the trouble could not be fixed up by yourself, please do not hesitate to contact EAE or its distributor to get professional help. The trouble will be judged and solved much faster if more details or pictures of the trouble can be provided.

TROUBLES	CAUSES	SOLUTIONS
Motor does not run and will not raise.	Loose wire connection	Check and make a good connection.
	Burnt motor.	Replace it.
	Damaged limit switch or its wire connection is loose.	Adjust or replace the limit switch.
Motor runs but will not raise.	The motor run reversely.	Check the wire connection.
	Overflow valve is not well screwed up or jammed.	Clean or make adjustment.
	Damaged gear pump.	Replace it.
	Too low oil level.	Add oil.
	The hose connection is loose.	Tighten it.
	The cushion valve is not well screwed up or jammed.	Clean or make adjustment
Platforms go down slowly after being raised.	The oil hose leaks.	Check or replace it.
	Untightened oil cylinder.	Replace the seal.
	The single way valve leaks.	Clean or replace it.
	Solenoid valve fails to work well.	Clean or replace it.
	Unloading valve leaks.	Check and adjust the tightness.
Raising too slow.	Jammed oil filter	Clean or replace it.
	Too low oil level.	Add oil.
	The overflow valve is not adjusted to the right position.	Make adjustment.
	Too hot hydraulic oil ( above 45° ) .	Change the oil.
	Abraded seal of the cylinder	Replace the seal.
Lowering too slow.	Jammed throttle valve	Clean or replace it.
	Dirty hydraulic oil	Clean or replace it.
	Jammed <i>parachute valve</i> .	Clean or replace it.
	Jammed oil hose	Clean it.

# MAINTENANCE

Easy and low cost routine maintenance can ensure the lift work normally and safely.

Following are requirements for routine maintenance.

Follow the below routine maintenance schedule with reference to the actual working condition and frequency of your lift.

**Lubricated moving parts with NO.1 lithium grease before use.**

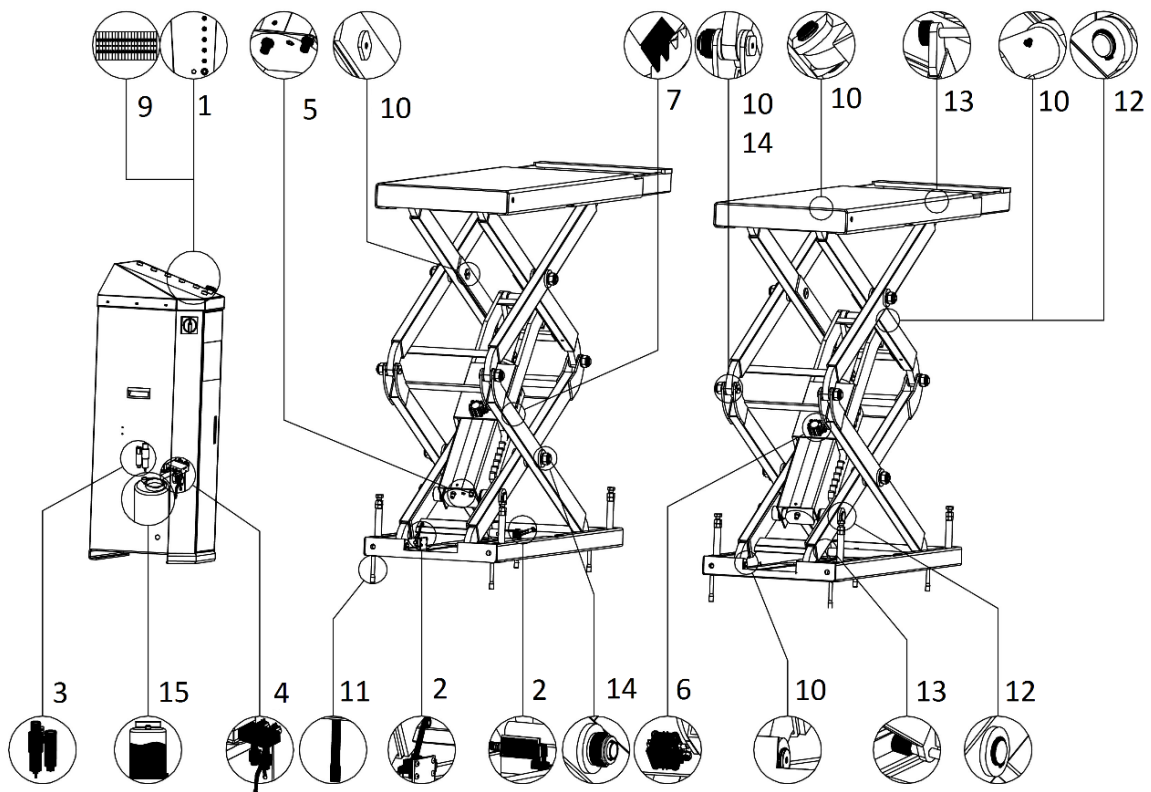

S/N	Components	Methods	Period
1	Control buttons	Check if control buttons work as "hold- to -run " and check if they work as the function indicated.	Every day
2	Max height limit switch	Push the UP button, inspect and ensure the lifting platform stops rising at maximum lifting height.	Every day
	Safe descent limit switch	Push the DOWN I button, inspect and ensure the lifting platform stops descending at proper height above ground.	Every day
3	Pneumatic filter	Listen and inspect the filter to ensure no leakage. Inspect and ensure the water level is below its max limit mark and the oil level is above the minimum limit mark.	Every day
4	Hydraulic block and valves	Inspect if the valves leak or not. Clean or change the valve if any leakage.	Every day
5	Oil hoses and connectors	Inspect to ensure no leakage before using the lift.	Every day
6	Pneumatic hoses and connectors	Inspect to ensure no leakage before using the lift.	Every day

S/N	Components	Methods	Period
7	Mechanical safety catch	Check if both mechanical catches can engage and disengage effectively and synchronously by pushing control buttons.	Every day
8	Alarming buzzer	Push DOWN II button to continue the lowering movement when the lifting platforms automatically stop lowering at safety height above the ground. Check if the buzzer alarms.	Every day
	Whole Lift	Running the lift for several cycles with and without rated load. The lift can run steadily and smoothly with no abnormal noise. Check the synchronization of both lifting platforms. Ensure both platforms ascend and descend synchronously.	Every day
9	Terminals in the control unit	Open the control unit, inspect the wire terminals and screw firmly if any terminals become loose.	Every 3 months
10	Joint shafts	Add grease into the oil cups.	Every 3 months
11	Anchored expansion bolts	Check with torque spanner. Torque: 60-80N.m	Every 3 months
12	Circlips of oil cylinder shaft	Inspect if any circlip goes off its groove. Make sure they are positioned in the grooves.	Every 3 months
13	Rolling wheels and their running tracks	Push the UP and DOWN button to check if the wheel is over-worn or cannot roll. Add grease to ensure smooth running. Change over-worn wheels.	Every 3 months
14	Self-locking nut	Check with torque spanner. The torque should be no less than 330N.m.	Every 3 months
15	Hydraulic oil	Change the oil 6 months after initial use and once per year thereafter. Inspect the hydraulic oil and change the oil if the oil becomes black or there is dirt in the oil tank.	Every year

*If users stick to the above maintenance requirements, the lift will always keep a good working condition and its service life could be extended.*

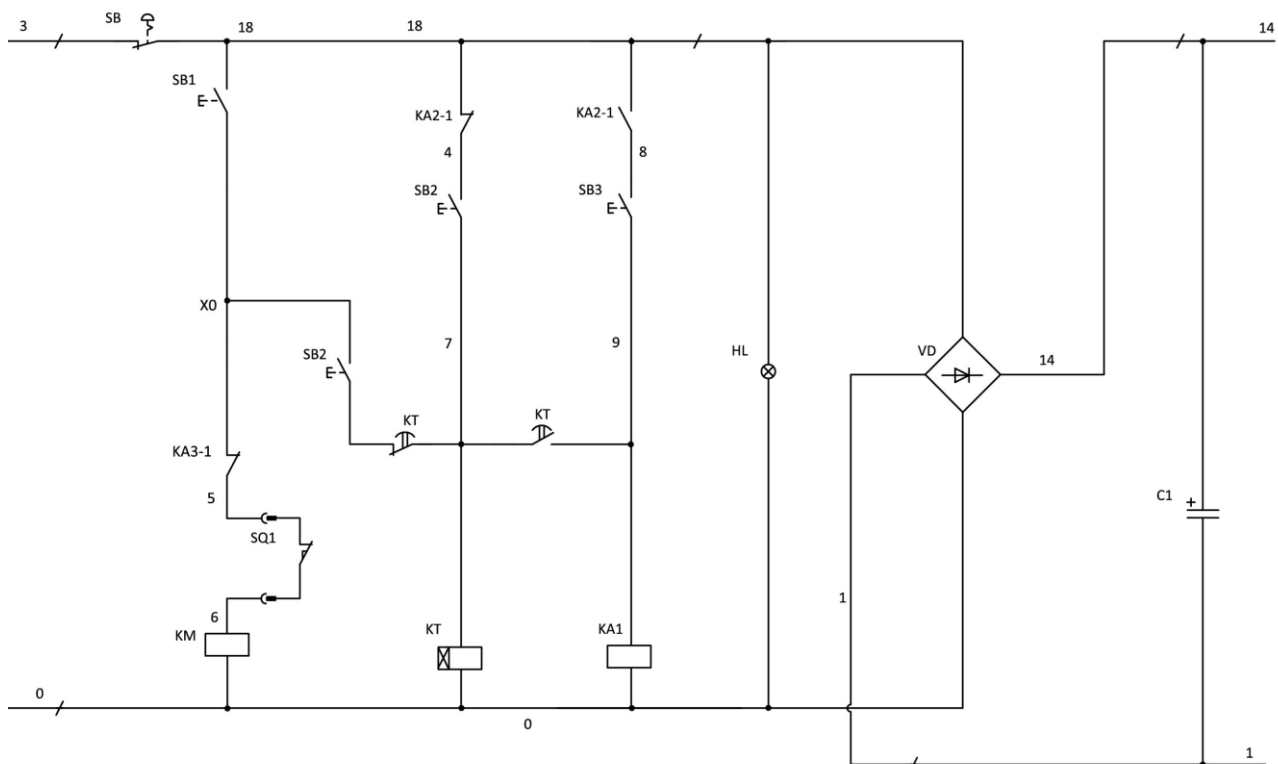
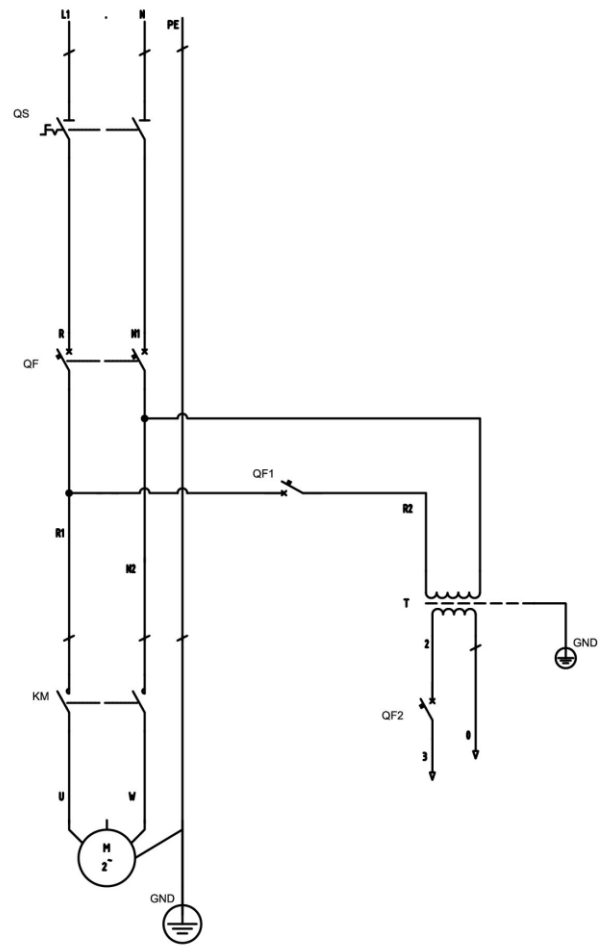
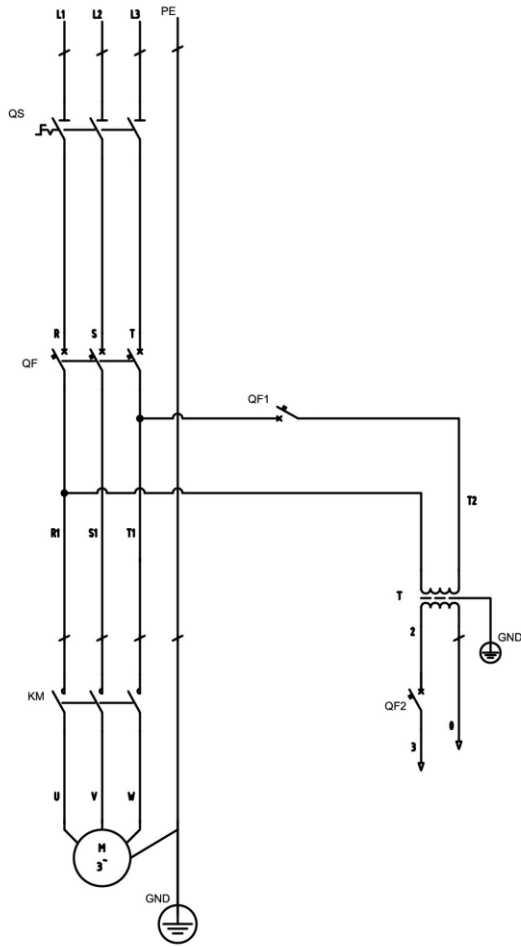
**Annex 1, Electrical diagrams and parts list**

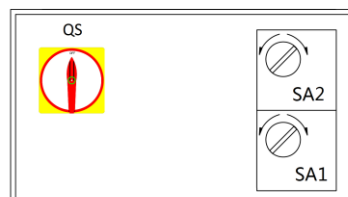
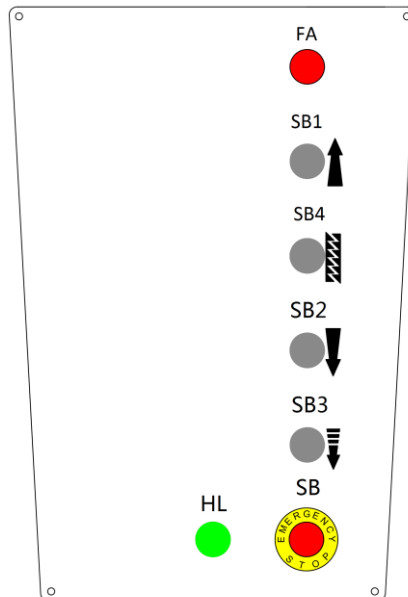
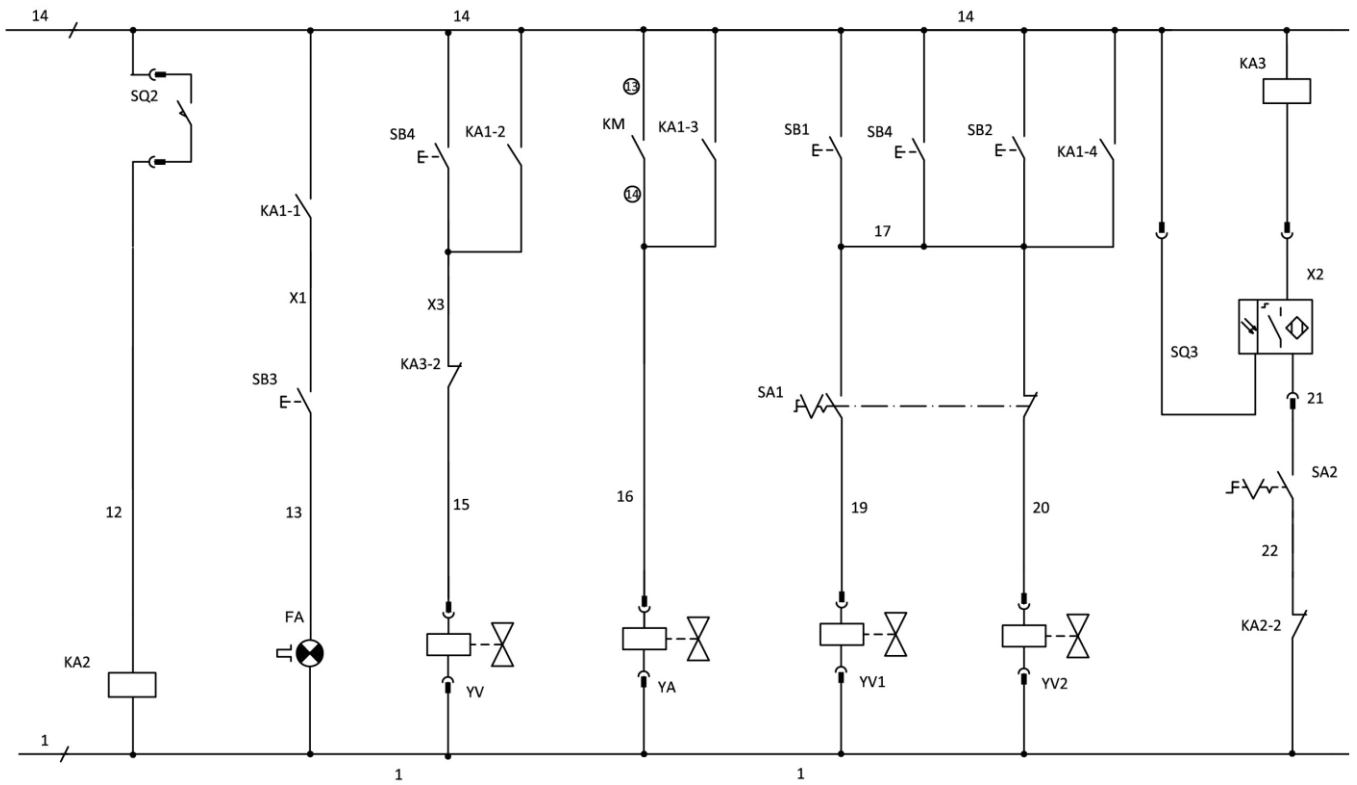



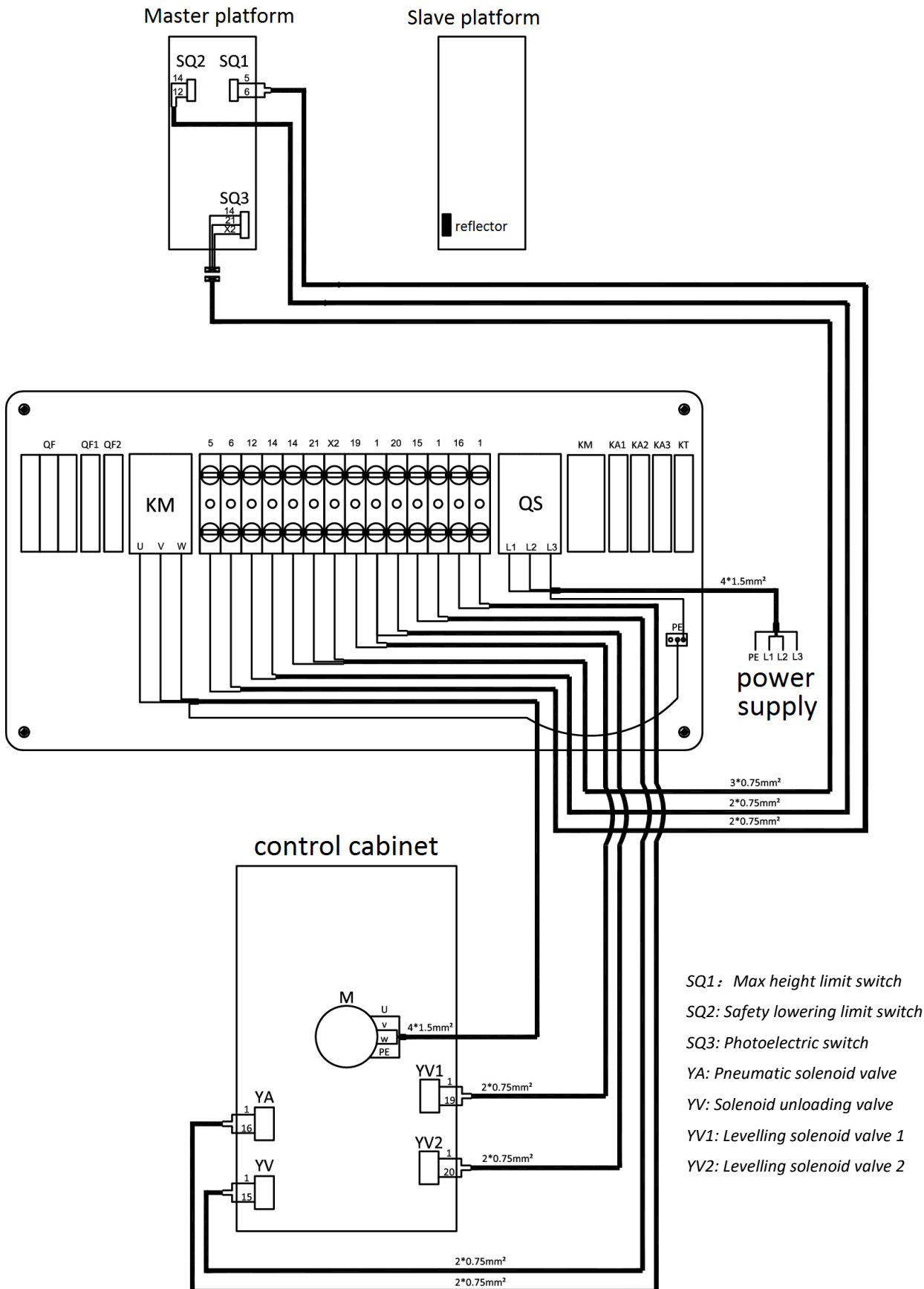

Pos.	Code	Description	Qty
T	320104004	Transformer (380V/400V/415V)	1
T	320104003	Transformer (220V/230V/240V)	1
T	320102004	Transformer (380V 220V-dual)	1
M		Motor	1
SQ1;SQ2	320301011	Limit switch	2
SQ3	320306025	Photoelectric switch	1
SA1;SA2	320303019	Selection switch	2
QS	320304001	Power switch	1
SB1;SB3;SB4	320401038	Button	3
SB2	320401044	Button	1
SB	320402002	Emergency stop	1
	320503002	Ground terminals	1
	320505006	Wire terminal	14
	320505011	Spacing Chip	2
KA2;KA3	320601001	Relay	2
KA1	320601002	Relay	1
	320601011	Relay holder	3
	320601018	Relay feet fixer	6
KT	320602009	Integrated time relay	1
QF	320802001	Circuit breaker (1Ph)	1
QF	320801001	Circuit breaker (3Ph)	1
QF	320801003	Circuit breaker (Dual)	1
QF1	320803001	Circuit breaker	1
QF2	320803003	Circuit breaker	1
KM	320901001	AC contactor (3Ph)	1
KM	320901011	AC contactor (1Ph)	1
C	321001004	Capacitor	1
VD	321002001	Bridge rectifier	1
HL	321201001	Power indicator	1
FA	321202001	Alarm buzzer	1

**NOTE: For power supply of other voltages, the transformer is different.  
Please check with our customers service people when order spare parts.**

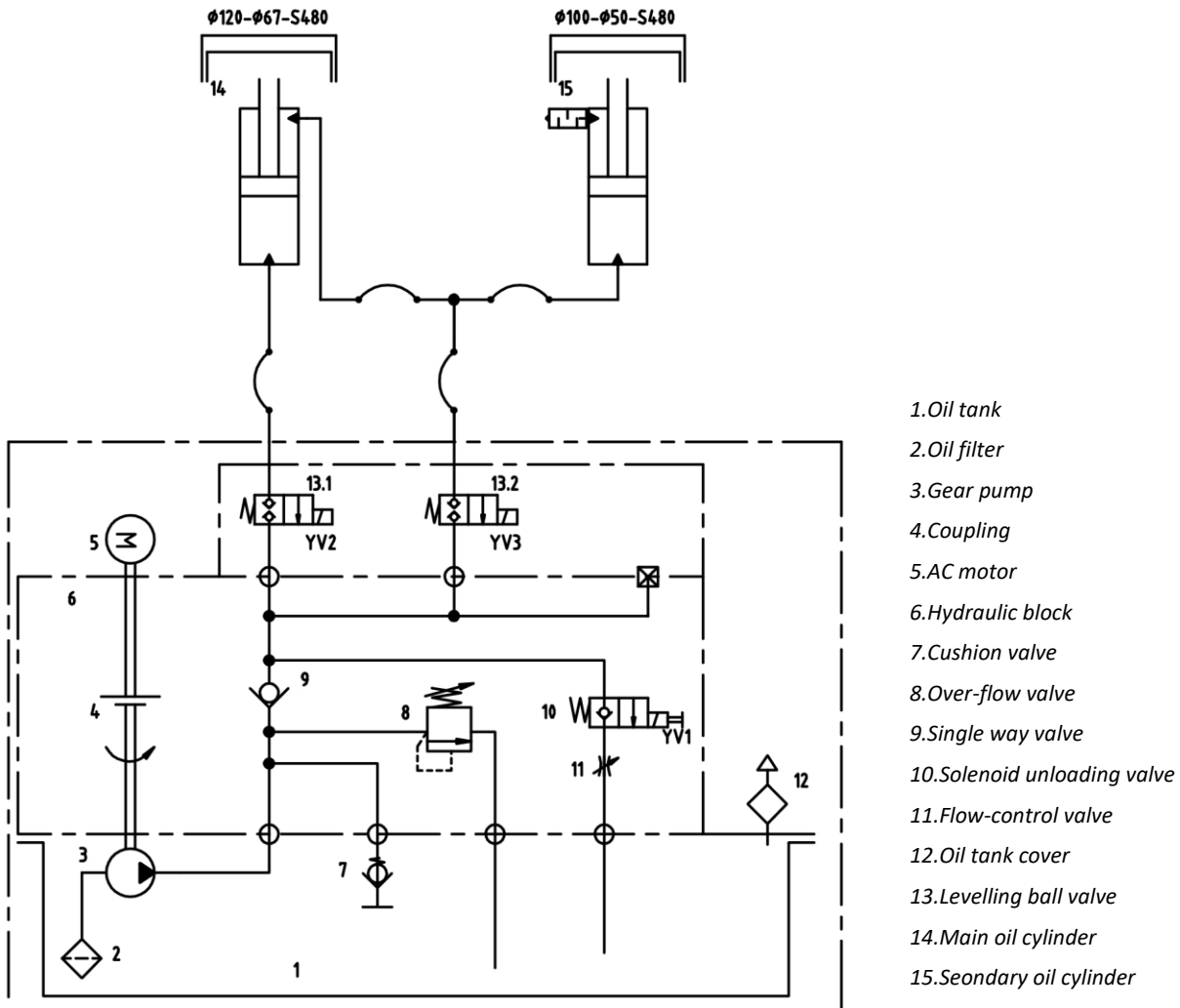
**Annex 2, Hydraulic diagrams and parts list**

**SEAL RINGS**

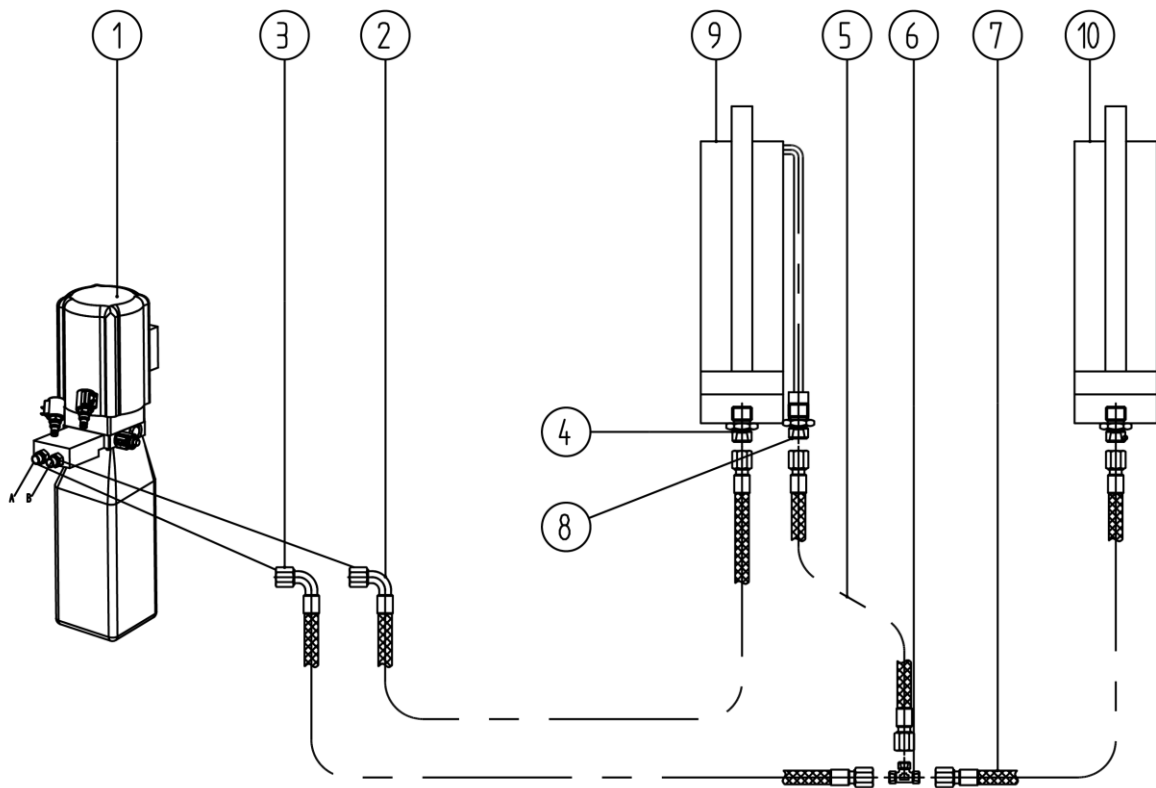
Cylinder code	Seal ring code	Description	Specification	Qty
615020001	207103009	Composite seal ring	KGD120*95*22.4*6.35	1
	207101005	Type O seal ring	53*3.55	1
	207101010	Type O seal ring	109*5.3	1
	207101011	Type O seal ring	118*3.55	1
	207102004	Type Y seal ring	SD67*77*6	1
	207105018	Dust proof ring	DH67	1
615020002	207103010	Composite seal ring	KGD100*75*22.4*6.35	1
	207101012	Type O seal ring	38.7*3.55	1
	207101013	Type O seal ring	92.5*3.55	1
	207105007	Dust proof ring	DHS50 (50*58*6)	1

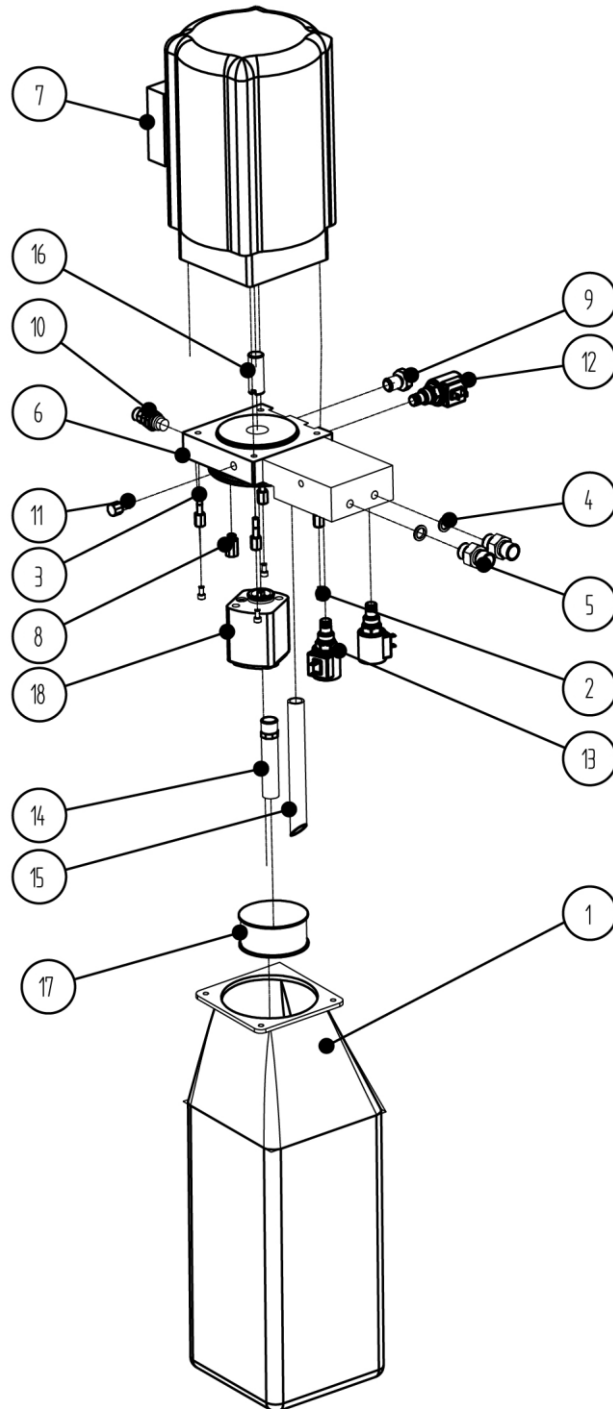

Pos.	Code	Description	Specification	Qty
1		Power unit	2.2kW	1
2	624001052	Rubber oil hose	L=3800	1
3	624001061	Rubber oil hose	L=4200	1
4	330305009	Straight throttle valve	BDPF-G14-G14-I60	2
5	624001056	Rubber oil hose	L=350	1
6	410210181	Three way connector	6603B-A9-B7	1
7	624001037	Rubber oil hose	L=1900	1
8	310101010	Connector B	G1/4--G1/4	1
9	615020001	Main oil cylinder	6503-A4-B1	1
10	615020002	The secondary oil cylinder	6503-A3-B2	1



Pos.	Code	Description	Specification	Qty
1	330405001	oil tank	10L	1
2	201102002	hex head full swivel screw	M5*10	4
3	202109064	oil tank installation screw	M6*30	4
4	207103025	composite washer	13.7*20.00*1.50(BS224)	2

Pos.	Code	Description	Specification	Qty
5	310101010	transfer fitting	G1/4---G1/4	2
6	330101033	hydraulic block		1
7	320201001	Motor	220V-2.2KW-1PH-50HZ-2p	1
	320201002	Motor	230V-2.2KW-1PH-50HZ-2P	1
	320201003	Motor	240V-2.2KW -1PH-50HZ-2P	1
	320201004	Motor	380V-2.2KW -3PH-50HZ-2P	1
	320201005	Motor	400V-2.2KW -3PH-50HZ-2P	1
	320201006	Motor	415V-2.2KW-3PH-50HZ-2P	1
	320204016	Motor	380V-3.0KW -3PH-50HZ-2P	1
	320204017	Motor	400V-3.0KW-3PH-50HZ-2P	1
	320204018	Motor	415V-3.0KW -3PH-50HZ-2P	1
	320201001	Motor	220V-2.2KW-1PH-50HZ-2p	1
8	330301001	cushion valve	HZYF-C1	1
9	330302001	single way valve	DYF-C	1
10	330304001	relief valve	EYF-C	1
11	330305002	throttle valve		1
12	330308006	unloading solenoid valve	DHF06-220H/DC24	1
13	330308008	levelling solenoid valve	DHF06-228H/DC24	2
14	330401005	oil sucking tube	XYGN-L293	1
15	330402001	oil back tube	YH-D	1
16	330404001	coupling	YL-A	1
17	330403001	filter	YG-C	1
18	330201005	Gear pump assembly (3Ph/2.2KW motor)	CBK-F220/CBK-2.1F	1
	330201007	Gear pump assembly ( 3Ph/3.0KW motor)	CBK-F233	1
	330201004	Gear pump assembly (1Ph/2.2kW motor)	CBK-F216	1

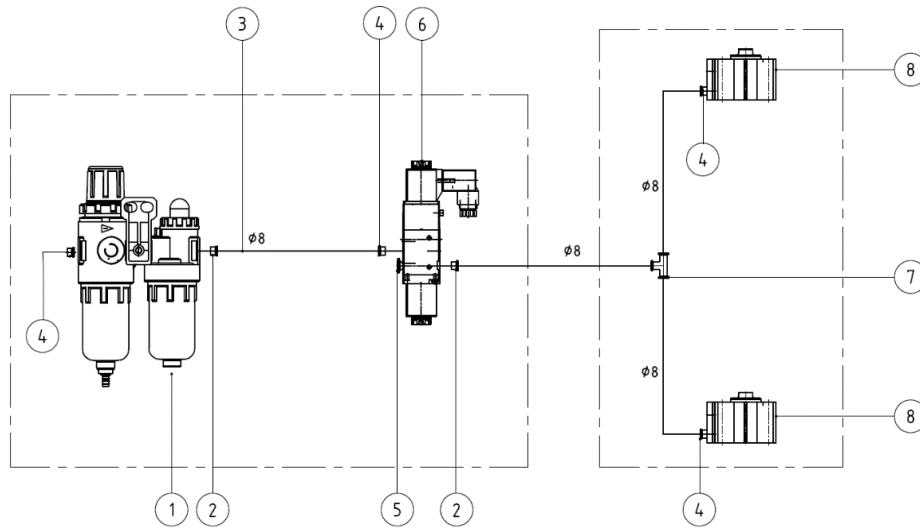
**Annex 3, Pneumatic diagrams and parts list**

Pos.	Code	Description	Specification	Qty
1	321004006	AFC Air filter combination	AFC2000	1
2	310101015	Pneumatic straight connector	KLC8-02	2
3	123010201	Air hose	DE8	1
4	310102015	Pneumatic elbow connector	KLL8-02	4
5	310201002	Silencer	SLM02 R1/8 (M8)	3
6	310401001	Pneumatic directional valve	3V210-08DC24V	1
7	310103006	Pneumatic three way connector	KLE-8	1
8	310501001	Pneumatic cylinder	CQ2B32*20	2

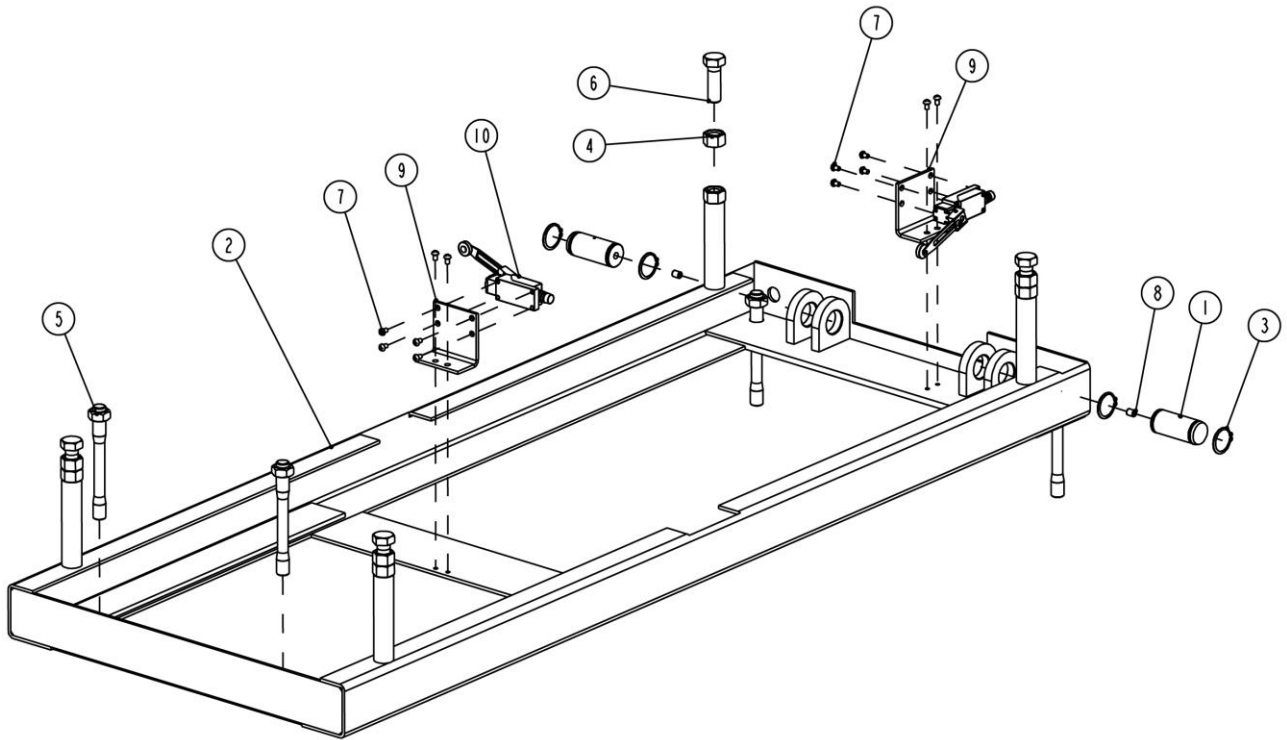
**Annex 4, Mechanically exploded drawings and parts list**

POS.	Code	Description	Specification	Qty
1	410200031	Shaft A	6503-A2	2
2	614901321	Base plate	6503V2-A1-B1	2
3	204301011	Circlip	D30-GB894_1	4
4	203101009	Hex nut	M16-GB_T6170	4
5	201201005	Expansion bolt M16*120	M16X120	4
6	201101102	Hex head full swivel screw	M16X180-GB5783	8
7	202101020	Cross socket cap head screw M5*8	M5X8_GB818	12
8	208106002	Straight oil cup	M8YP_GB7940_4	2
9	410470271	Installation plate for limit switch	TSS30-A8	2
10	320301011	Limit switch	TZ8108	2



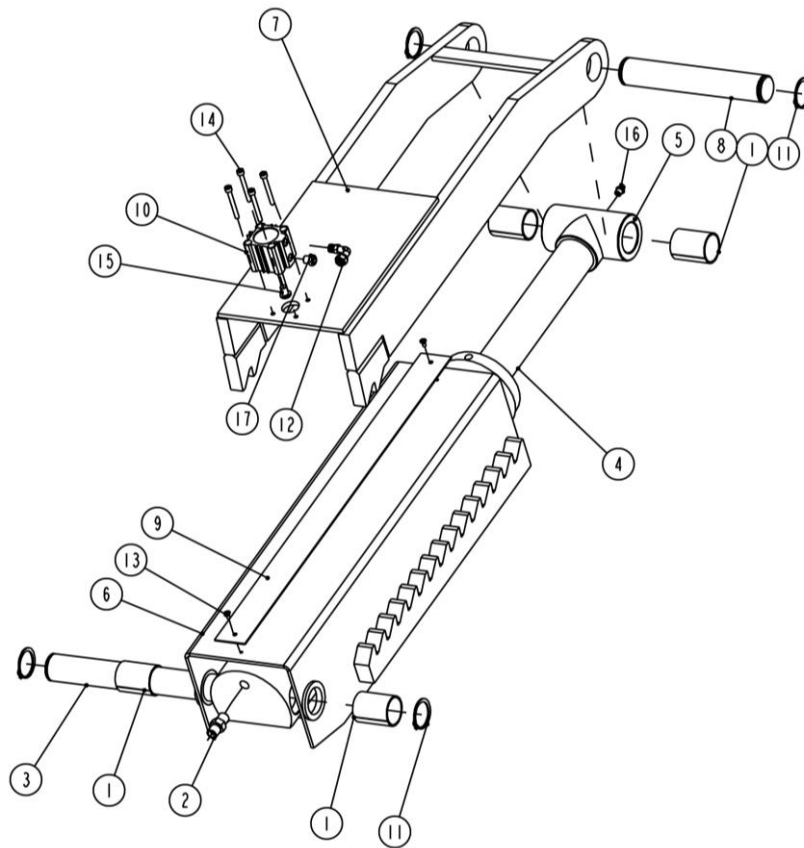

POS.	Code	Description	Specification	Qty
1	205101030	Bearing	3550-SF-2X	4
2	<b>330305009</b>	Straight fitting with flow restrictive valve	<b>BDPF-G14-G14-I60</b>	1
3	410200101B	Rotate shaft of oil cylinder	6503-A3-B1	1
4	615020002	The secondary oil cylinder	6503-A3-B2	1
5	410203403	Oil cylinder connector	6503V2-A3-B6	1
6	614020212B	Sheath for secondary oil cylinder	6503V2-A3-B3	1
7	614020213	Mechanic lock assembly	6503V2-A3-B5	1
8	410203251	UP shaft of oil cylinder	6503V2-A3-B8	1
9	410203290B	Stainless steel pad plate	6503V2-A3-B9	1
10	310501001	Pneumatic cylinder	CQ2B32X20	1
11	204301012	Circlip	D35_GB894-2	4
12	310102024	Quick pneumatic connector	KLL8-01	1
13	202101007	Cross socket cap head screw	M4*8	2
14	202109014	Hex socket cylinder head screw	M5X45_GB_T70_1	4
15	202110004	Hex socket button head screw	M8X12_GB70_2	1
16	208106001	Straight oil cup	M8X1_JBT7940_1	1
17	310201003	Silencer	SLM01-R1-8	1

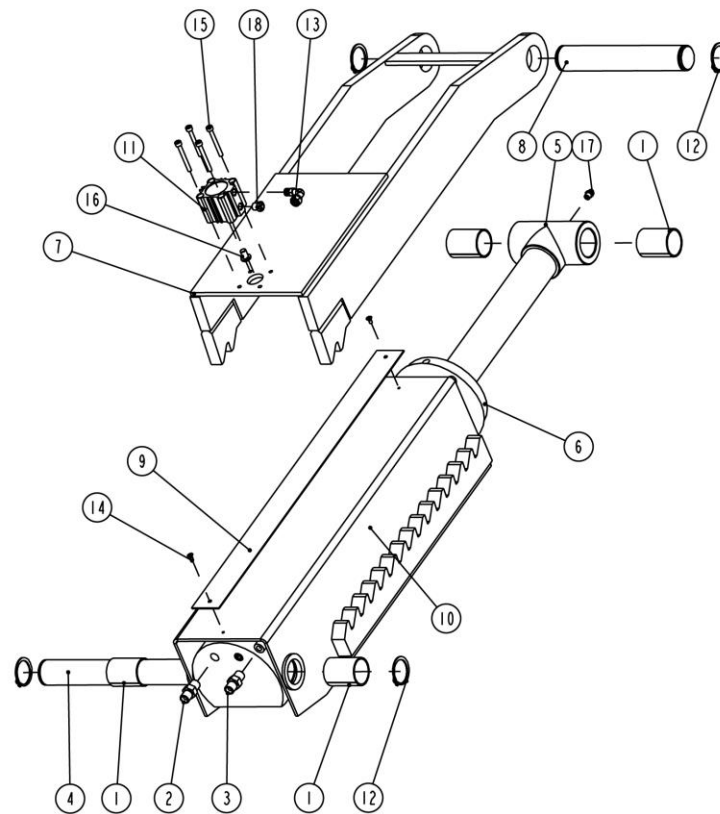

POS.	Code	Description	Specification	Qty
1	205101030	Bearing	3550-SF-2X	4
2	330305009	Straight fitting with flow restrictive valve	BDPF-G14-G14-I60	1
3	310101010	Straight fitting	G1/4---G1/4	1
4	410200101B	Rotate shaft of oil cylinder	6503-A3-B1	1
5	410203403	Oil cylinder connector	6503-A3-B6	1
6	615020001	Main oil cylinder	6503-A4-B1	1
7	614020213	Mechanic lock assembly	6503V2-A3-B5	1
8	410203251	UP shaft of oil cylinder	6503V2-A3-B8	1
9	410203290B	Stainless steel pad plate	6503V2-A3-B9	1
10	614020214	Sheath for main oil cylinder	6503V2-A4-B2	1
11	310501001	Pneumatic cylinder	CQ2B32X20	1
12	204301012	Circlip	D35_GB894-2	4
13	310102024	Quick pneumatic connector	KLL8-01	1
14	202101007	Cross socket flat head screw	M4*8	2
15	202109014	Hex socket cylinder head screw	M5X45_GB_T70_1	4
16	202110004	Hex socket button head screw	M8X12_GB70_2	1
17	208106001	Straight oil cup	M8X1_JBT7940_1	1
18	310201003	Silencer	SLM01-R1-8	1

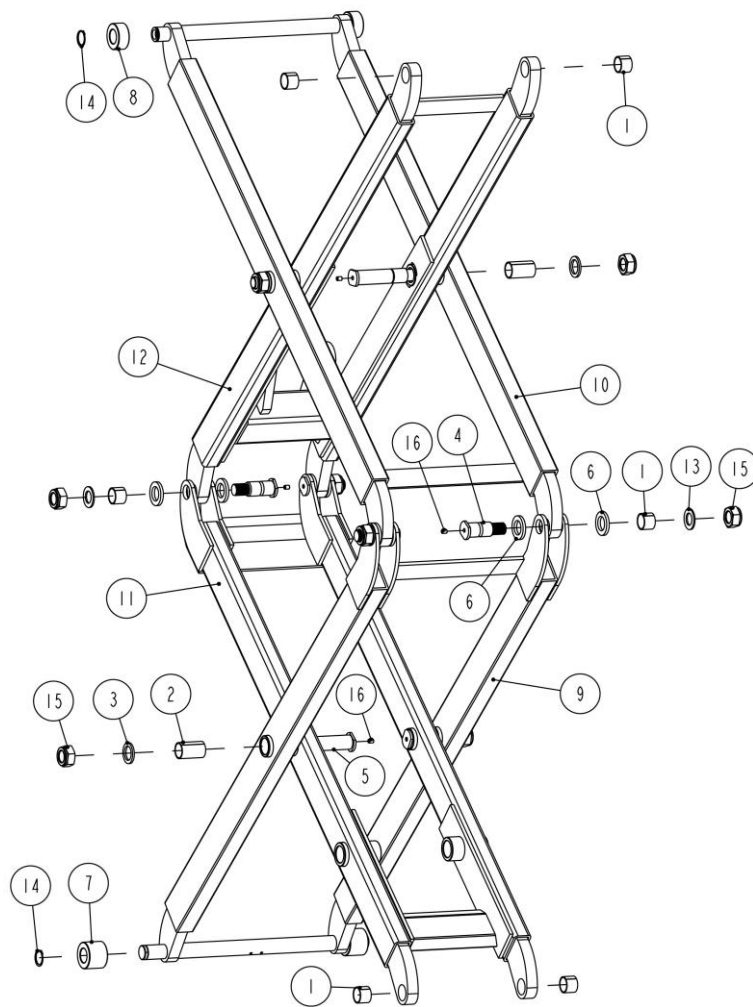

Pos.	Code	Description	Specification	Qty
1	205101018	Bearing	3025-SF-1	8
2	205101025	Bearing	3058-SF-1	4
3	410190101	Thin space ring	6501-A2-B8	4
4	410200171	Pin shaft C	6503-A7	4
5	410200141C	Pin shaft B	6503-A5-B5	4
6	410200181	Bracket washer	6503-A5-B7	8
7	410200450	Nylon down wheel	6503-A5-B2-C3	2
8	420200030	Nylon roller	6503-A5-B2-C4	2
9	614068006	Rotate arm B	6503-A5B-B2	1
10	614068007	Rotate arm C	6503-A5B-B3	1
11	614068013	Rotate arm A	6503V2-A5B-B1	1
12	614068014	Rotate arm D	6503V2-A5B-B4	1
13	204101012	Flat washer C	M24_GB95	4
14	204301011	Circlip	D30_GB894-2	4
15	203103011	Hex locking nut	M24_GB889_1	8
16	208106002	Straight oil cup	M8YP_GB7940_4	8

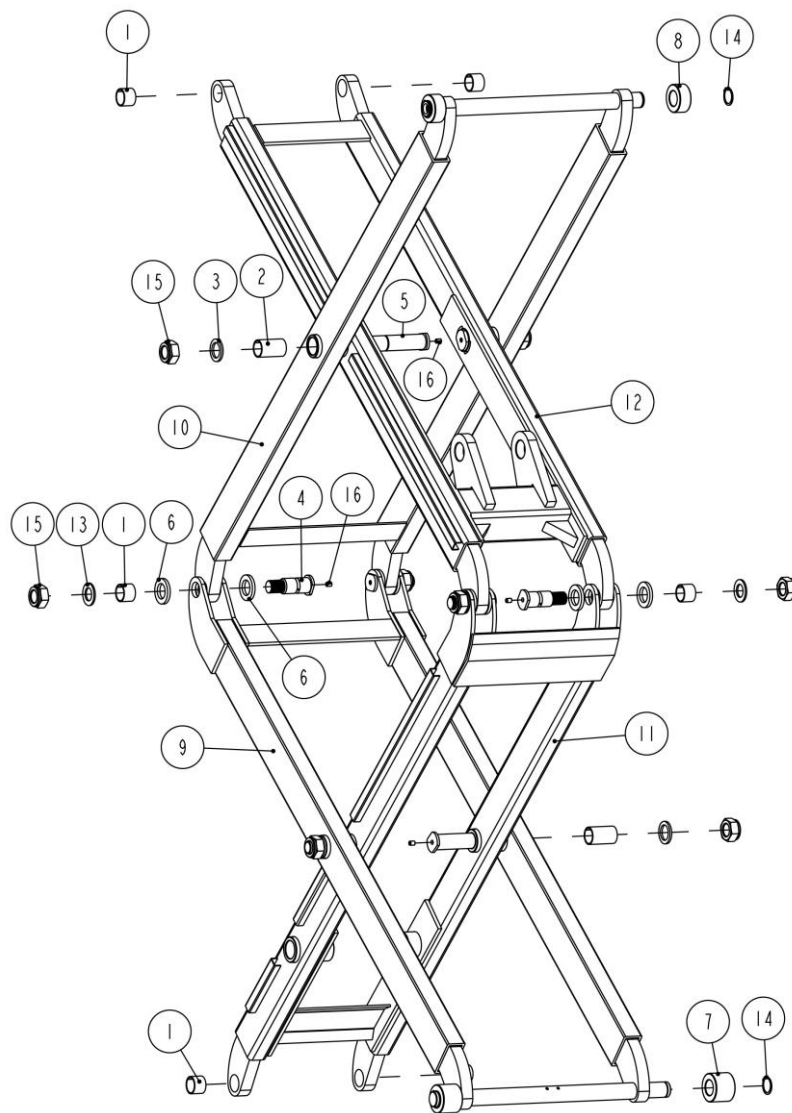

Pos.	Code	Description	Specification	Qty
1	205101018	Bearing	3025-SF-1	8
2	205101025	Bearing	3058-SF-1	4
3	410190101	Thin space ring	6501-A2-B8	4
4	410200171	Pin shaft C	6503-A7	4
5	410200141C	Pin shaft B	6503-A5-B5	4
6	410200181	Bracket washer	6503-A5-B7	8
7	410200450	Nylon down wheel	6503-A5-B2-C3	2
8	420200030	Nylon roller	6503-A5-B2-C4	2
9	614068006	Rotate arm B	6503-A5B-B2	1
10	614068007	Rotate arm C	6503-A5B-B3	1
11	614068011	Rotate arm A	6503V2L-A5B-B1	1
12	614068012	Rotate arm D	6503V2L-A5B-B4	1
13	204101012	Flat washer C	M24_GB95	4
14	204301011	Circlip	D30_GB894-2	4

Pos.	Code	Description	Specification	Qty
15	203103011	Hex locking nut	M24_GB889_1	8
16	208106002	Straight oil cup	M8YP_GB7940_4	8

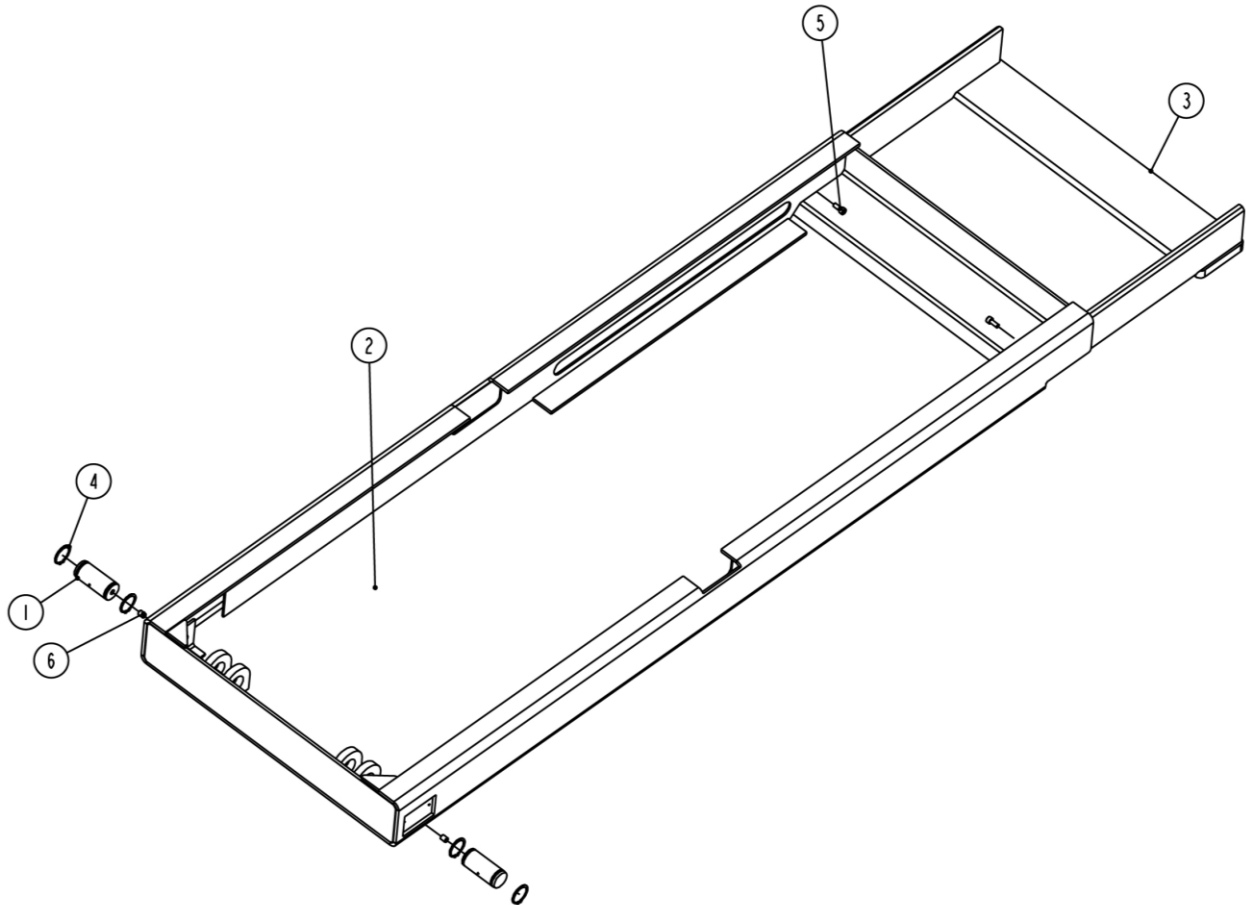

POS.	Code	Description	Specification	Qty
1	410200031	Shaft A	6503-A2	2
2	614901323	Lifting platform (A)	6503V2-A7-B3	1
	614901324	Lifting platform (B)	6503V2-A7-B4	1
3	614020219	Platform extension	6503V2L-A7-B3	1
4	204301011	Circlip	D30-GB894_1	4
5	202109027	Hex socket cylinder head screw	M8*12	2
6	208106002	Straight oil cup	M8YP_GB7940_4	2