

Model No. EE-HX50BWF.PD8

Long platform scissor lift

Electrical Levelling

Pneumatic Controlled Slip Plate

Lifting Capacity 5000kg

Installation, Operation and Parts Manual



EAE

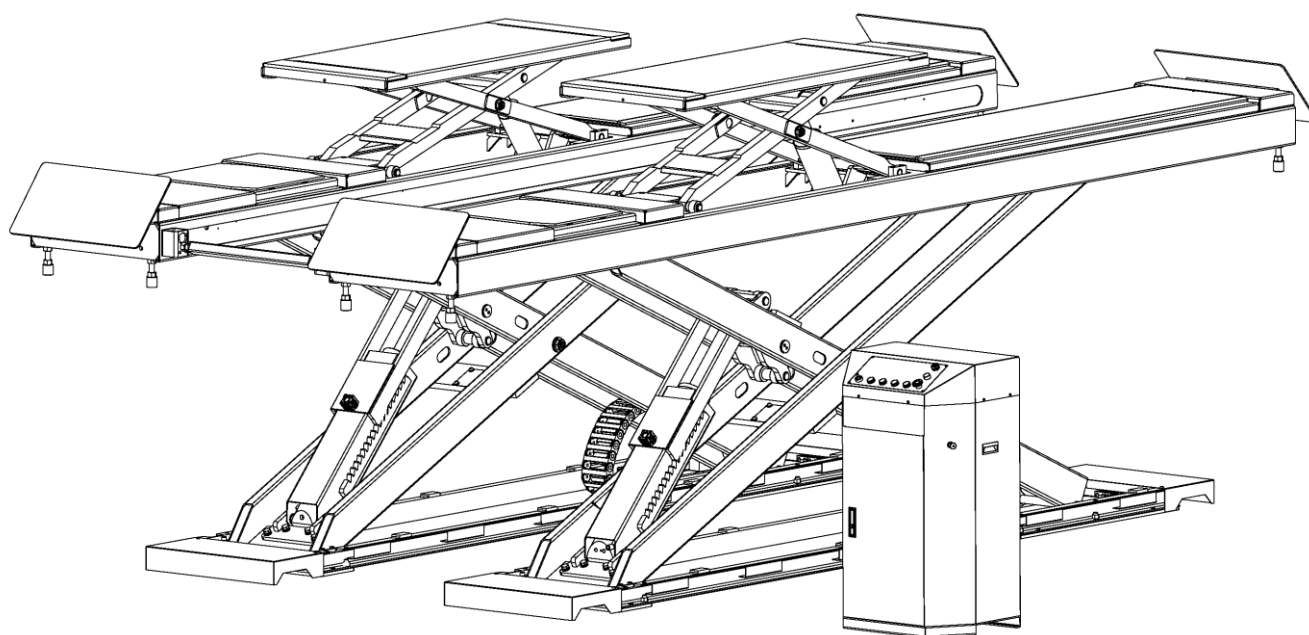

Distributed by

Please read this entire manual carefully and completely before installation or operation of the lift.

DATE: 13/11/2023

www.eae-ae.com

IMPORTANT NOTES

Before start up, connecting and operating EAE products, it is absolutely essential that the operating instructions/owner's manual and, in particular the safety instructions are studied carefully. By doing so you can eliminate any uncertainties in handling EAE products and thus associated safety risks up front; something which is in the interest of you own safety and will ultimately help avoid damage to the device, When an EAE product is handed over to another person, not only the operating instructions but also the safety instructions and information on its designated use must be handed over to the person.

By using the product you agree the following conditions:

Copy right

The enclosed instructions are the property of EAE or its supplier, and are protected against duplication and reproduction by copyright laws, international agreements, and other domestic legislation. The reproduction or disclosure of instructions or an extract thereof is prohibited and offenders are liable to prosecution; EAE reserves the right or initiates criminal proceedings and asserts claims for damages in the event of infringements.

Warranty

The use of non-approved hardware will result in a modification of our products and thus to the exclusion of any liability or warranty, even if such hardware has been removed again in the interim.

It is not permissible to make any changes to our products and these are not only to be used together with genuine accessories and genuine replacement parts. Otherwise any warranty claims will be invalid.

Liability

The liability of EAE is limit to the amount that the customer has actually paid for this product. This exclusion of liability does not apply to damages caused through willful misconduct or gross negligence on the part of EAE.

All information in this manual is believed to be correct at time of publication.

EAE reserves the right to amend and alter technical data and composition without prior notice.

Please confirm at time of ordering.

<i>IMPORTANT NOTES</i>	2
<i>SAFETY NOTES</i>	4
1.1 <i>Operation of lifting platforms</i>	4
1.2 <i>Checking of the lifting platforms</i>	4
1.3 <i>Important safety notices</i>	5
1.4 <i>Warning labels</i>	6
1.5 <i>Potential safety risks</i>	7
1.6 <i>Noise level</i>	7
<i>PACKING, STORAGE AND TRANSPORTATION</i>	8
2.1 <i>The lift was dismantled into 3 parts for transportation</i>	8
2.2 <i>Lifting and handling</i>	8
<i>PRODUCT DESCRIPTIONS</i>	9
3.1 <i>General descriptions</i>	9
3.2 <i>Construction of the lift</i>	9
3.3 <i>Dimensions</i>	10
3.4 <i>Safety device descriptions</i>	11
3.5 <i>Technical data</i>	12
<i>INSTALLATION INSTRUCTIONS</i>	12
4.1 <i>Preparations before installation</i>	12
4.2 <i>Installation attentions</i>	13
4.3 <i>General Installation Steps</i>	14
4.4 <i>Items to be checked after installation</i>	17
<i>OPERATION INSTRUCTIONS</i>	17
5.1 <i>Precautions</i>	17
5.2 <i>Descriptions of control panel</i>	18
5.3 <i>Flow chart for operation</i>	18
5.4 <i>Operation instructions</i>	19
<i>TROUBLE SHOOTING</i>	22
<i>MAINTENANCE</i>	24
<i>Annex 1, Floor Plan</i>	26
<i>Annex 2, Electrical schemes and parts list</i>	27
<i>Annex 3, Hydraulic schemes and parts list</i>	33
<i>Annex 4, Pneumatic schemes and parts list</i>	40
<i>Annex 5, Mechanically exploded drawings and parts list</i>	41

SAFETY NOTES

1.1 Operation of lifting platforms

This lift is specially designed for lifting motor vehicles. Users are not allowed to use it for any other purposes. The applicable national regulations, laws and directives must be observed.

Only users aged 18 or above who have been instructed on how to operate the lifting platform and have proven their ability to do so to the owner are to be entrusted with unsupervised operation of lifting platforms. The task of operating the lifting platforms must be granted in writing.

Before loading a vehicle onto the lifting platform, users should study the original operation instructions and familiarize themselves with the operating procedures in several trial runs.

1.2 Checking of the lifting platforms

Checks are to be based on the following directives and regulations:

- Basic principles for testing lifting platforms
- The basic safety requirements stipulated in the directive 2006/42/EC
- Harmonized European standards
- The applicable accident prevention regulations

The checks are to be organized by the user of the lifting platform. The user is responsible for appointing an expert or qualified person to perform checking.

The user bears special responsibility if employees of the company are appointed as experts or qualified persons.

1.2.1 Scope of checking

Regular checking essentially involves performing a visual inspection and a functional test. This includes checking the condition of the components and equipment, checking that the safety systems are complete and functioning properly and that the inspection log book is completely filled in. The scope of exceptional checking depends on the nature and extent of any structural modification or repair work.

1.2.2 Regular checking

After initial commissioning, lifting platforms are to be checked by a qualified person at intervals of not longer than one year.

A qualified person is somebody with the training and experience required to possess sufficient knowledge of lifting platforms and who is sufficiently familiar with the pertinent national regulations, accident prevention regulations and generally acknowledged rules of engineering to be able to assess the safe operating condition of lifting platforms.

1.2.3 Exceptional checking

Lifting platforms with a lift height of more than 2 meters and lifting platforms intended for use with people standing under the load bearing elements of the load are to be checked by an expert prior or reuse following structural modifications and major repairs to load bearing components.

An expert is somebody with the training and experience required to possess specialist knowledge of lifting platforms and who is sufficiently familiar with the pertinent national work safety regulations, accident prevention regulations and generally acknowledged rules of engineering to be able to check and give an expert opinion on lifting platforms.

1.3 Important safety notices

- 1.3.1 Recommend for indoor use only. DO not expose the lift to rain, snow or excessive moisture.
- 1.3.2 Only use this lift on a surface that is stable, level and dry and not slippery, and capable of sustaining the load. Do not install the lift on any asphalt surface.
- 1.3.3 Read and understand all safety warnings before operating the lift.
- 1.3.4 Do not leave the controls while the lift is still in motion.
- 1.3.5 Keep hands and feet away from any moving parts. Keep feet clear of the lift when lowering.
- 1.3.6 Only these properly trained personnel can operate the lift.
- 1.3.7 Do not wear unfit clothes such as large clothes with flounces, tires, etc., which could be caught by moving parts of the lift.
- 1.3.8 To prevent evitable incidents, surrounding areas of the lift must be tidy and with nothing unconcerned.
- 1.3.9 The lift is simply designed to lift the entire body of vehicles, with its maximum weight within the lifting capacity.
- 1.3.10 always insure the safety locks are engaged before any attempt to work near or under the vehicle. Never remove safety related components from the lift. Do not use if safety related components are damaged or missing.
- 1.3.11 do not rock the vehicle while on the lift or remove any heavy component from vehicle that may cause excessive weight shift.
- 1.3.12 Check at any time the parts of the lift to ensure the agility of moving parts and the performance of synchronization. Ensure regular maintenance and if anything abnormal occurs, stop using the lift immediately and contact our dealers for help.
- 1.3.13 Lower the lift to its lowest position and do remember to cut off the power source when service finishes.
- 1.3.14 do not modify any parts of the lift without manufacturer's advice.
- 1.3.15 if the lift is going to be left unused for a long time, users are required to:
- a. Disconnect the power;
 - b. Empty the oil tank;
 - c. Lubricate the moving parts with grease.

WARNING: The warnings, cautions and instructions discussed in this instruction manual cannot cover all possible conditions and situations that may occur. It must be understood by the operator that common sense and caution are factors which cannot be built into this product, but must be supplied by the operator.

Attention: For environment protection, please dispose the disused oil in a proper way.

1.4 Warning labels

All safety warning labels are clearly depicted on the lift to ensure that the operator is aware of and avoid the dangers of using the lift in an incorrect manner. The labels must be kept clean and they have to be replaced if detached or damaged. Please read carefully the meaning of each label and memories them for future operation.

SAFETY ADVICE
540101444

 <p>Only trained personnel are allowed to operate the lift.</p>	<p>Always keep lift area clear when lowering or raising vehicle.</p> 
 <p>Do not try to raise a vehicle exceeds the rated capacity.</p>	<p>Never raise or lower a vehicle with one side platform.</p> 
 <p>Watch closely the vehicle during raising or lowering.</p>	<p>It is not allowed to work under the vehicle if safety teeth are not engaged.</p> 
 <p>Make sure that two platforms are of equal height from the floor when safety teeth engaged.</p>	<p>Avoid excessive rocking of vehicle while on lift.</p> 
 <p>Do not climb onto the lift platforms or raised vehicle during lifting or lowering.</p>	<p>Always keep the lift pit clean and clear of any objects or contaminants.</p> 
 <p>Do not change the safety mechanism.</p>	<p>Carryout maintenance regularly as indicated in the manual.</p> 

1.5 Potential safety risks

1.5.1 Mains voltage



Insulation damage and other faults may result in accessible components being live

Safety measures:

- Only ever use the power cord provided or a tested power cord.
- Replace wires with damaged insulation.
- Do not open the operating unit.

1.5.2 Risk of injury, danger of crushing



In the event of excessive vehicle weight, incorrect mounting of the vehicle or on removing heavy object, there is a risk of the vehicle falling off the lifting platform or tipping up.

Safety measures:

- The lifting platform is only ever to be employed for the intended purpose.
- Carefully study and heed all the information given in Section 1.4.
- Observe the warning notices for operation.

1.6 Noise level

Noise emitted during operating the lift should be less than 70dB (A). For your health consideration, it is suggested to place a noise detector in your working area.

PACKING, STORAGE AND TRANSPORTATION

Packing, lifting, handling, transporting operations must be performed only by experienced personnel with appropriate knowledge of the lift and after reading this manual.

2.1 The lift was dismantled into 2 parts for transportation

Name	Packed by	Dimension(mm)	Weight(kg)	Quantity
Control cabinet	Wooden case	700x560x1300	170	1
2 lifting platforms	Steel bracket	5420x700x830	2800	1

The packs must be kept in a covered and protected area in a temperature range of -10°C to $+40^{\circ}\text{C}$. They must not be exposed to direct sunlight, rain or water.

Stacking the packs

We advise against stacking because the packs are not designed for this type of storage. The narrow base, heavy weight and large size of the packs make stacking difficult and potentially dangerous.

If stacking is unavoidable, use all appropriate precautions:

- never stack to more than 2 meters in height.
- never make stacks of single packs. Always stack pairs of packs in a cross pattern so that the base is bigger and the resulting stack is more stable. Once the stack is complete, restrain it using straps, ropes or other suitable methods.

A maximum of two packs can be stacked on lorries, in containers, and in railway wagons, on condition that the packs are strapped together and restrained to stop them falling.

2.2 Lifting and handling

The packs can be lifted and transported only by using lift trucks. The center of gravity and lashing points are marked on the packaging. Never attempt to hoist or transport the unit using lifting slings.

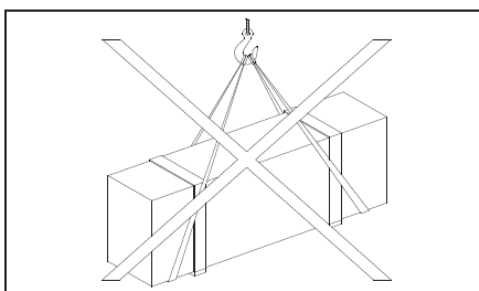
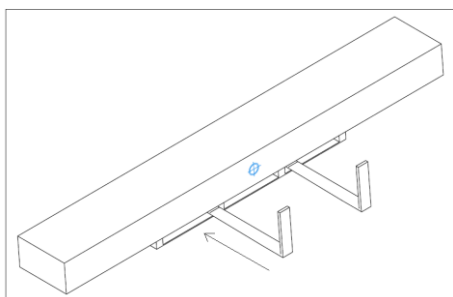

Opening the packs

When the lift is delivered make sure that it has not been damaged during transportation and that all the parts specified on the packing list are present.

Packs must be opened adopting all the precautions required to avoid injury to persons (keep at a safe distance when cutting the straps) or damage to parts of the machine (be careful that no parts are dropped while you are opening the packing)

Take special care with the hydraulic power unit, the control panel and the platform cylinder.

PRODUCT DESCRIPTIONS

3.1 General descriptions

This is heavy duty wheel-support vehicle lift with auxiliary wheel-free lifting device. It is preferably for recessed mounting and is mainly composed by two lifting platforms and a power and control cabinet. Being hydraulically powered, the gear pump delivers oil to push upwards the pistons of oil cylinders and let the scissor arms of the lift rise accordingly.

The lift is fitted with a PD system with an RF wireless controller so that the PD can be operated whilst under the vehicle allowing inspection of the underside of the vehicle.

3.2 Construction of the lift

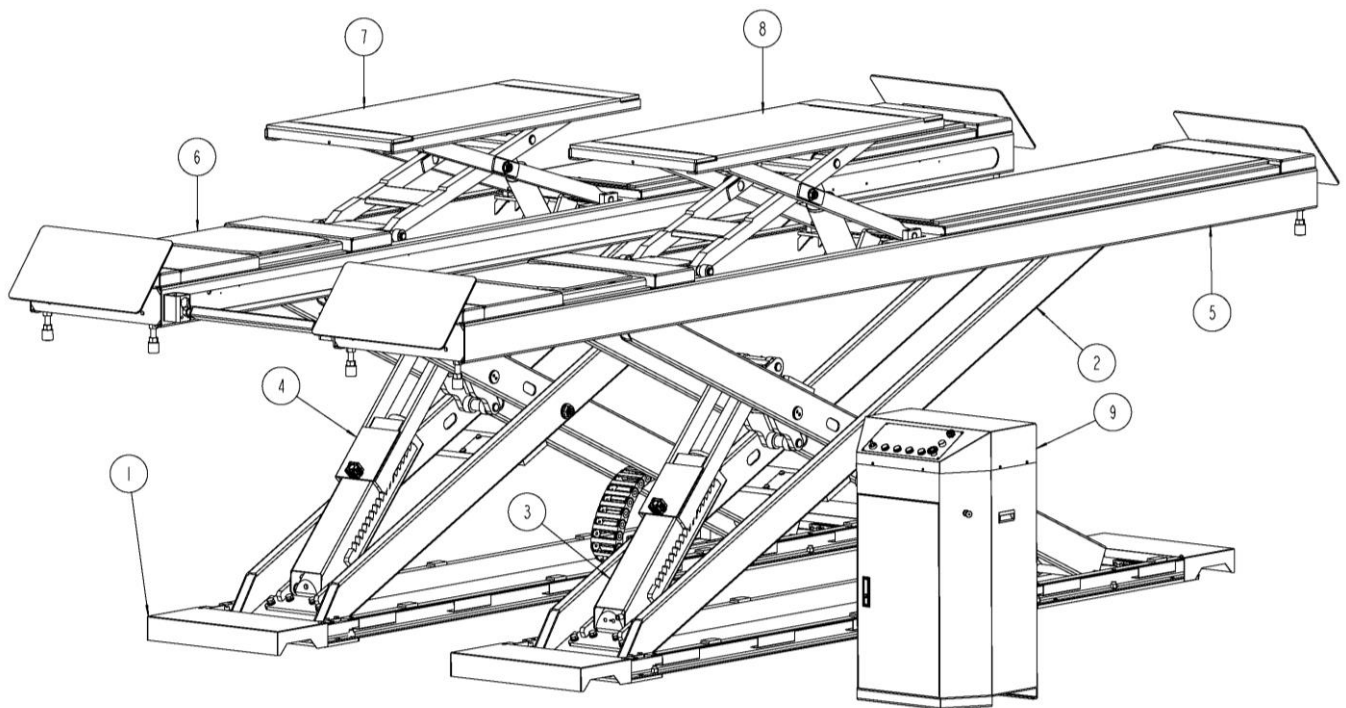

1. Base frame assembly
2. Scissor arm assembly
3. Master cylinder assembly
4. Slave cylinder assembly
5. Wheel-support platform A assembly
6. Wheel-support platform B assembly
7. Slave wheel-free platform
8. Master wheel-free platform
9. Control and power unit

3.3 Dimensions

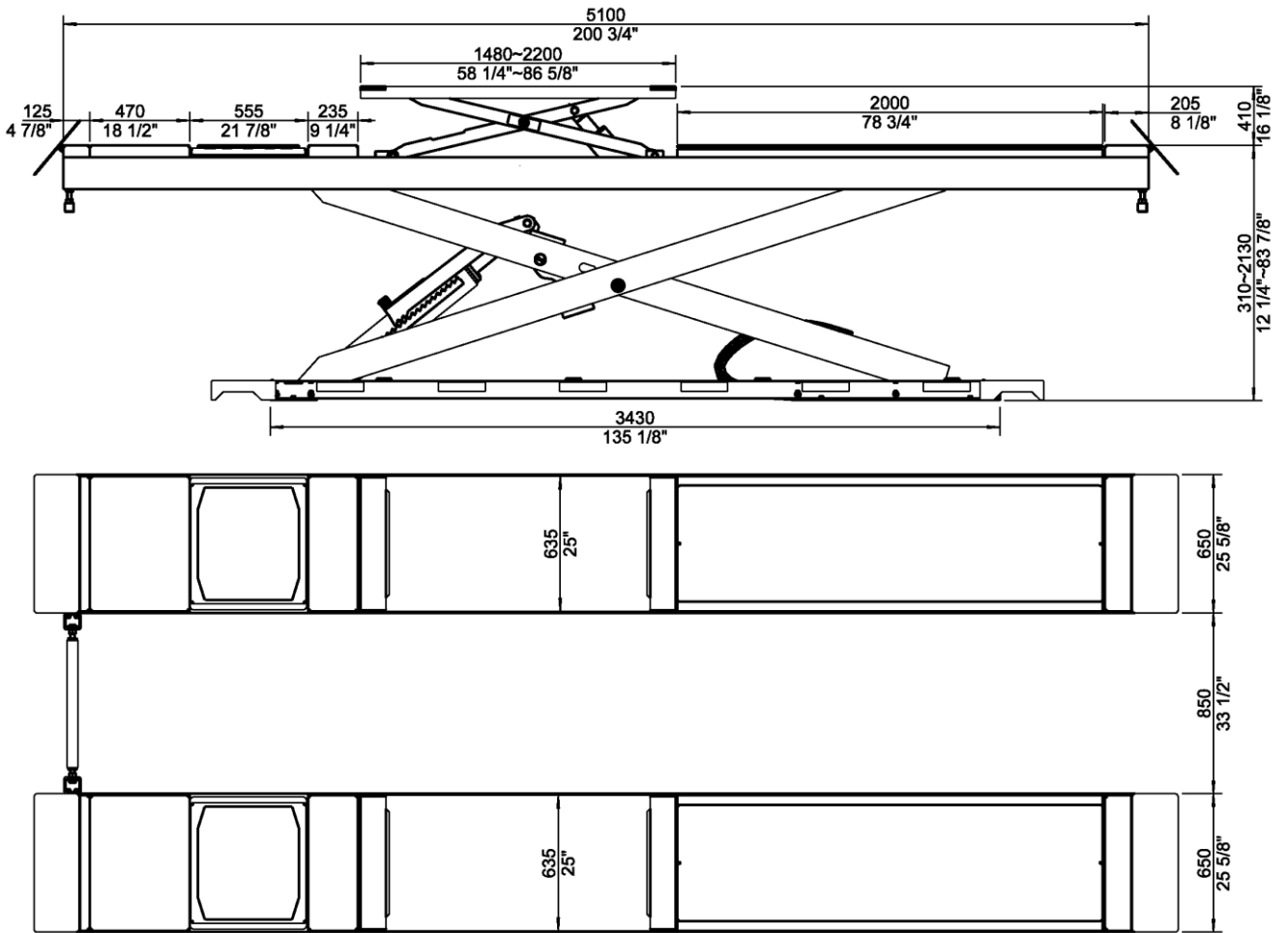

3.4 Safety device descriptions

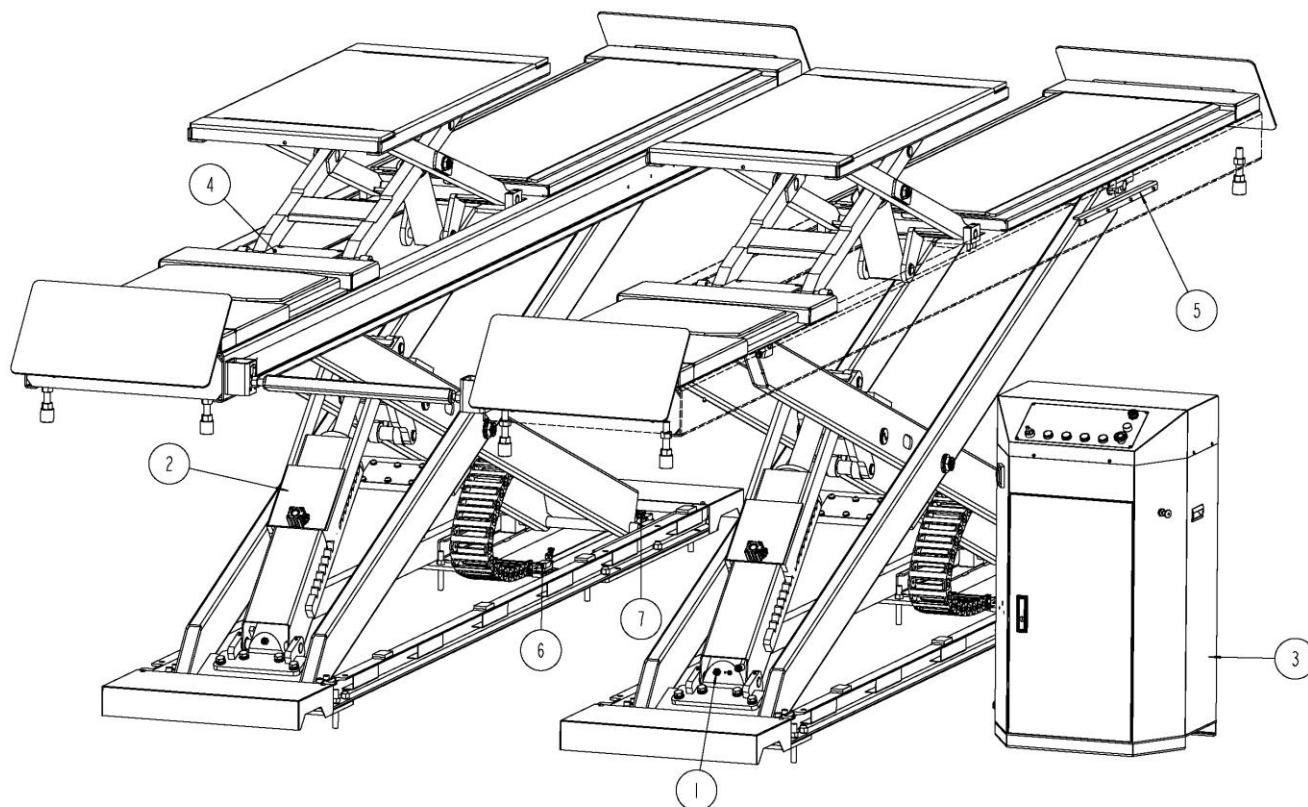

NO.	Safety device	Function
1	Restrictive valve	Protect the platform from lowering too faster, in case of leakage in the hydraulic circuit.
2	Mechanical safety locking unit	Catching device preventing unintentional lowering. Hold still the lifting platform in case of hydraulic leakage.
3	24V safe control voltage	Safety voltage for operator.
4	Protective device against tipping up	Protect the wheel-free platform from tipping up, in case of unbalanced load distribution.
5	Protection against tipping up	Protect wheel-support platform from tipping up, in case of unbalanced load distribution.
6	Max height limit switch for main lifting platform	Limit the max. Rise by switching off the control circuit to ensure the platform stop rising at maximum lifting height.
7	Limit switch for safe lowering	Protective device which stops the movement of the lift for the purpose of feet protection. The lifting platforms automatically stop lowering at a safe height above the ground. Push an additional DOWN II button to restart the lowering movement which is accompanied by an audible warning alerting service persons being away from the moving parts.

3.5 Technical data

Rated capacity of the main lift (kg)	5000
Rated capacity of the wheel-free lifting platform (kg)	4000
Full raised height of the wheel-support lifting platform (mm)	2130
Full raised height of the wheel-free lifting platform (mm)	410
Initial height (mm)	310
Full raised time (with rated load)	Approx.25s (3.5kWx2,3ph)
Full lowered time (with rated load)	25-40s (adjustable)
Max .Hydraulic working pressure (MPa)	26
Pneumatic working pressure (bar)	6-8
Oil tank volume (L)	28

INSTALLATION INSTRUCTIONS

4.1 Preparations before installation

4.1.1 Space requirements.

Indoor installation only. Refer to 3.4 for the dimensions of the lift. There must also be a clearance of at least 1 meter between the lifting platform and fixed elements (e.g. wall) in all lifting positions. There must be sufficient space for driving vehicles on and off.

4.1.2 Foundations and connections

The user must have the following work performed before erecting the lift.

- Construction of the foundation following consultation with the manufacturer's customer service or an authorized service agent.
- Routing of the wiring to the installation location. The user must provide fuse protection for the connection. Requirements for power supply cable of the installation site: at least 2.5mm² wire core for 3Ph power.
Attention: electrical connection must be done by licensed technicians.
- Refer also to the corresponding information on the name plate and in the operation instructions. Before doing electrical connection, make sure the lift is electrically adapt to the local power supply.
- Routing of the compressed air connection to the installation location.

4.1.3 Foundations preparations (see Annex 1, floor plan)

C25/30 concrete base with a minimum thickness of 200mm.

Surface: Horizontal and even (Gradients max. 0.5 %).

Newly built concrete ground must be older than 20days.

4.1.4 Tools and equipment needed for installation

Tool Description	Specification	Qty
Electrical drill	With D16 drill bit.	1
Open spanner	D17-19mm	2
Adjustable spanner	At least D30mm	1
Cross socket screw driver	PH2	1
Quick spanner handle adapter/ Ratchet		1
Socket spanner	D24mm	1
Levelling device		1
Hammer	10 pounds	1
Truck lift	Capacity 3000kg	1
Lifting strap	Capacity,1000 kg	2
Lifting strap	Capacity,1500 kg	2
Torque spanner	MD400	1

4.1.5 Checking parts

Unfold the package and check if any parts missed as per the following list. Do not hesitate to contact us in case any parts missed, but if you do not contact us and insist installing upon the lack of some parts, we as well as our dealers will not bear any responsibility for this and will charge for any parts subsequently demanded by the buyer.

S/N	Description	Specification	Qty
1	Lifting platform	HX50BWF	2
2	Control cabinet	/	1
3	Expansion bolt	M16x120	16
4	Rubber pad	38*120*100	4
5	Installation manual		1
6	Key of the cabinet		1
7	Oil tank label		1
8	Key fob.		1
9	Inspection torch		1

4.2 Installation attentions

4.2.1 Tighten all hydraulic and electrical connections.

4.2.2 Tighten all screws, nuts and bolts.

4.2.3 Do not place any vehicle on the lift in the case of trial running.

4.3 General Installation Steps

ONLY TRAINED AND QUALIFIED INSTALLERS CAN PERFORM LIFT INSTALLATION DUTIES.

Step 1: Dismantle the package of the lifting platforms.

Remove the carton and packing films wrapped on the platform.

WARNING! : Take off oil hose protectors when cut off the packing strips.

WARNING! : Avoid scratching the painting surface and hoses.

Step 2: Place the lifting platform at expected installation site with a forklift and lifting straps.

Raise the platform by using a forklift and 2 lifting straps until the mechanical lock is engaged. Hoist the platform onto the expected installation site.

WARNING! : Before hoisting, make sure the hoses and wires are well protected against damage.

WARNING! : It is necessary to hold the platform during the hoisting process. Irrelevant person is not allowed in installation area.

Step 3: Open the package of the control cabinet and take out accessories in it.

Step 4: Connect hydraulic oil hoses.

Connect the oil hoses fittings to the power unit as per the diagram for oil hose connection. Annex 3.

Connect as per the marks attached with the hoses. Don't let any solid substance go into the hydraulic line.

Adequate care must be taken to assure that all fittings and connectors are screwed tight against leakage

Step 5: Connect the pneumatic release system

Refer to Annex 4.

Screw torque for pneumatic hose connector is 20Nm.

External compressed air shall be prepared by the end user before installation. Pneumatic pressure 6-8 bar.

Keep the hoses clean during the connection.

Set the pneumatic pressure between 6-8 bars.

Push upward the button indicated in the following fig and turn the button until the hand of the meter points to the NUMBER"6". Push the button down thereafter.



It is suggested to add ISO VG32 mechanical oil into the oil tank.

Adjust the oil dipping quantity using the button on top of the oil cup.

Step 6: Connect the electrical system.

Refer to electrical connection diagram before making the connection.

Attention: electrical system connection must be done by qualified electricians.

Connect the wire connectors for limit switches and LED lamps.

Connect the main power supply cable to external electricity supply.

(For three phase power supply, if the lift doesn't raise and the motor turn in the wrong direction, in such event, interchange the connection of wire L1 with L2 or L3 to correct the phase sequence.)

Step 7: Fill with hydraulic oil.

CLEAN AND FRESH OIL ONLY. DON'T FILL THE TANK COMPLETELY FULL.

Lift must be fully lowered before changing or adding hydraulic oil

Fill at least 26 liters hydraulic oil into the oil reservoir.

Add more oil after running the lift for several cycles until the lift can rise to the maximum lifting height.

Note: It is suggested to use HM NO.46 hydraulic oil. Use HM NO.32 hydraulic oil when temperature is below 10 degree Celsius.

Change the oil 6 months after initial use and change once per year thereafter.

Step 8: Levelling

Check the connection of the hydraulic and electrical system before levelling operation.

Refer to 5.2 and get familiar with the function of all control buttons and switches.

Attention: Correct the sequence order of the motor's wiring, in the case that the motor runs but the platform does not move upwards after pushing "UP" button for more than 30 seconds. Interchange wires U, V in the control cabinet).

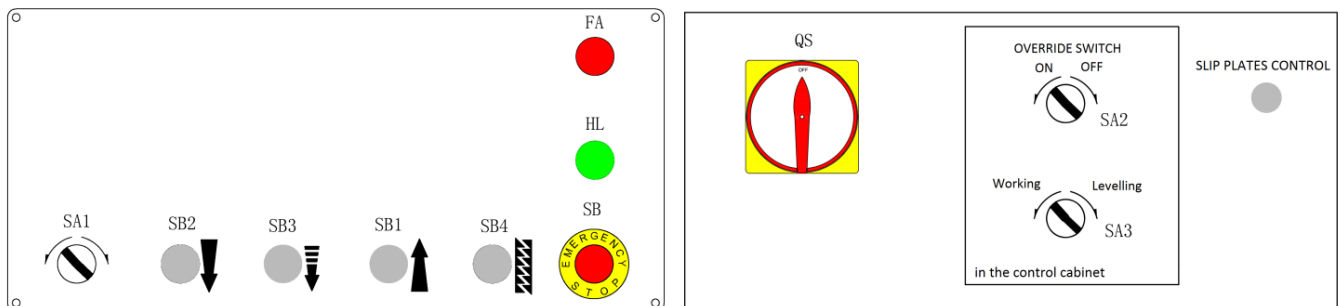

Level the wheel-support platforms

- 1) Connect the power supply and turn on the Main Switch. Turn the switch -SA1 on control panel to wheel-support platform.
- 2) Open the door of the control cabinet. Turn off the OVERRIDE switch-SA2 and turn the switch-SA3 to "Levelling" mode. Push the "UP" button until the slave platform raises to the maximal height. After that, push the DOWN button SB2 until it is completely lowered to the bottom position.
- 3) Turn the switch-SA3 to "Working" mode and push "UP" button to check if both platforms have run synchronously with no obvious height deviation. On condition that asynchronization still exists, turn the switch-SA3 to "Levelling" mode again. Check and adjust the height of the slave platform to make it park at the same level with master platform. (Push the UP button to raise the slave platform in case it is lower than the master platform. Push the DOWN button to lower the slave platform in case it is higher than master platform) If synchronization is still not achieved, repeat the above levelling steps until synchronization reached.
- 4) Turn on the OVERRIDE switch -SA2 and turn the switch-SA3 to "Working" mode.

Level the wheel free platforms

- 1) Turn the switch -SA1 on control panel to the wheel-free lift. Turn the switch-SA3 to "Levelling" mode.
- 2) Push the "UP" button until the slave platform raises to the maximal height. After that, push the DOWN button-SB2 until it is completely lowered to the bottom position.
- 3) Turn the switch-SA3 to "Working" mode and push "UP" button to check if both platforms have run synchronously with no obvious height deviation. Turn the switch-SA3 to "Levelling" mode again, on condition that asynchronization still exists. Push the UP or DOWN button to adjust the height of the slave platform to make it park at the same level with master platform.
- 4) Turn the switch-SA3 to "Working" mode and push UP and DOWN button to check the synchronization.

Step 8: Fix base frames with expansion bolts.

Speciation of the bolts: M16x120

- 1) Before anchoring, it is necessary to check again the position for each base plates by referring to the dimension scheme as well as the corresponding installation requirements.
- 2) Drill holes using D16 carbide tipped masonry drill bit. Make sure to drill vertically down.
- 3) Clean the hole and check again the position of the base plates to ensure they are correctly positioned.
- 4) Use a spirit level to check the vertical alignment of the two adjacent base plates.
- 5) Impact and drive anchoring bolt into hole until its nut and washer contacts the base.
- 6) Tighten the nut with torque wrench to 80Nm.

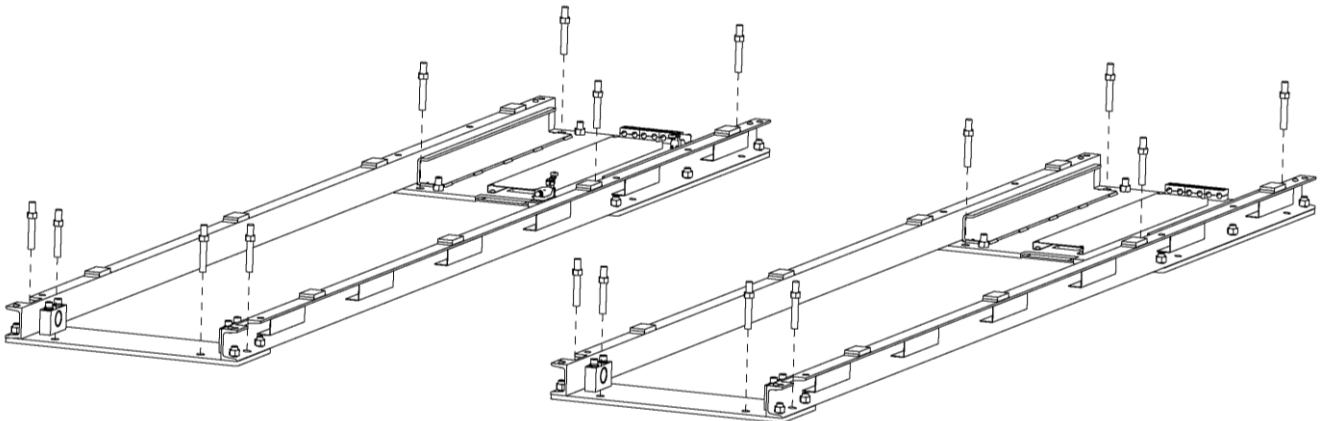

Step 9: Install the mechanical connecting bar

Place the bar into the reserved holders at the front part of the two platforms.

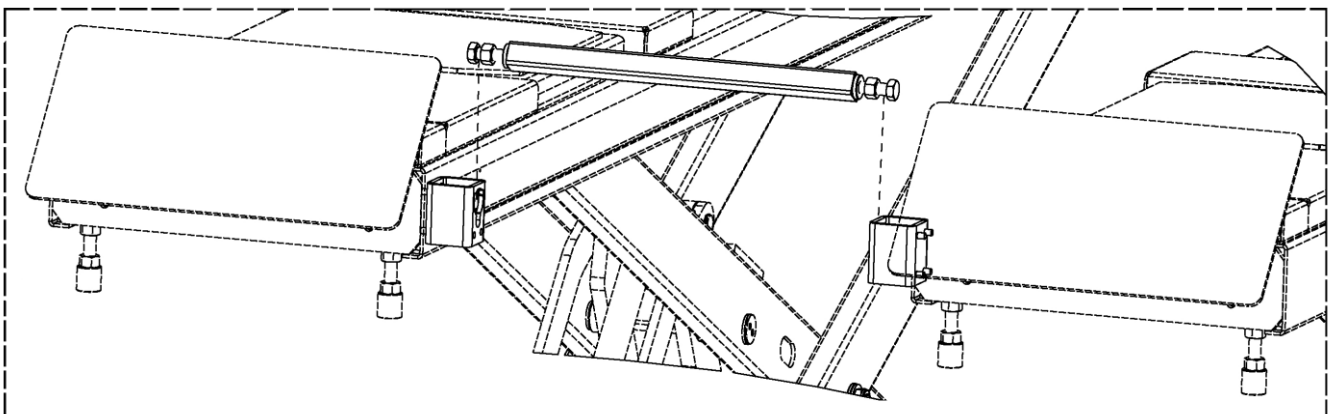

4.4 Items to be checked after installation.

S/N	Check items	YES	NO
1	Screw torque of expansion bolts :60-80Nm;	√	
2	Rising speed ≥ 20 mm/s;	√	
3	Noise with rated load ≤ 75 dB(A);	√	
4	Grounding resistance: not bigger than 4 Ω ;	√	
5	Height difference of the two carriages ≤ 5 mm;	√	
6	Mechanical catch unit is robust and synchronized when running with rated load ;	√	
7	All control buttons works as "hold to run" ;	√	
8	The limit switches work well ;	√	
9	The grounding wire is connected ;	√	
10	The carriage rises and lowers smoothly ;	√	
11	There is no abnormal noise when run with load ;	√	
12	There is no oil leakage when run with load ;	√	
13	The expansion bolts, nuts or circlips are well secured or tightened ;	√	
14	The max lifting height can be reached ;	√	
15	All Safety advices, name plate and logos are clear.	√	

OPERATION INSTRUCTIONS

5.1 Precautions

- 5.1.1 Read and digest the complete operation instructions before operating the lift.
- 5.1.2 Only authorized persons are permitted to operate the lift.
- 5.1.3 Do not try to raise the vehicle with excessive length or width.
- 5.1.4 The space above and below the load as well as of the loading carrying devices shall be free of obstructions.
- 5.1.5 Position supporting pads to pick-up positions recommended by vehicle manufacturers.
- 5.1.6 Check the vehicle after raising a short distance to ensure that it is corrected and safely positioned.
- 5.1.7 The load carrying device shall be observed by the operator throughout the motion of the lift.
- 5.1.8 Engage the safety locking mechanism before entering under the raised vehicle.
- 5.1.9 Avoid excessive rocking of vehicle while on the lift
- 5.1.10 It is forbidden for people to stand in the field of motion during raising or lowering movement.
- 5.1.11 do not climb onto the load or load carrying device when they are raised.

5.2 Descriptions of control unit

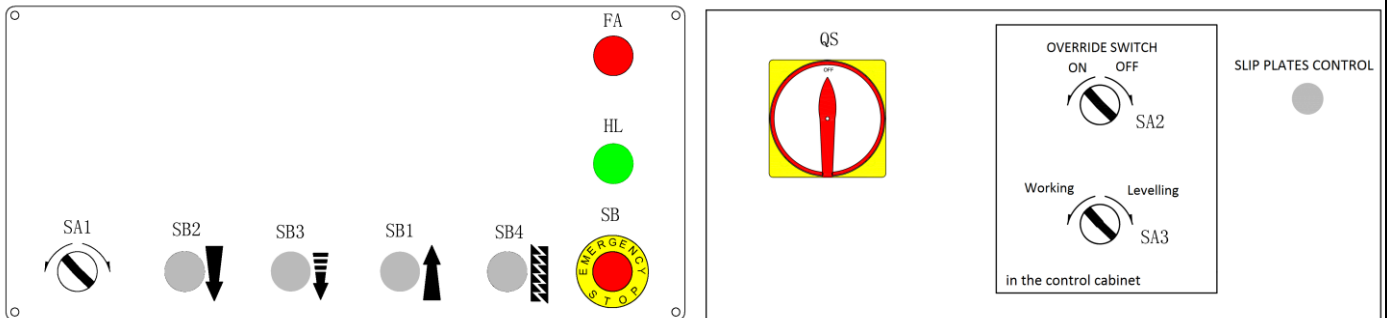

POS.	Description	Function
FA	Alarm buzzer	Audible warning for descent of the final travel
HL	Power indicator	Illuminate to show the power is on.
SB	Emergency stop	Disconnect the power in emergency cases
SB1	UP button	Control the rising movement
SB2	DOWN button	Control the initial lowering movement
SB3	DOWN button	Control the final lowering movement
SB4	LOCK button	Engage the mechanical locking device
SA1	Selection switch	Select to run the Main lift, PD or Wheel-free jack
QS	Main switch	Power on /off
SA2	Selection switch	Turn on or off the synchronization protective device
SA3	Selection switch	Control working or levelling mode
	SLIP PLATES CONTROL	Lock or release the slip plates

5.3 Flow chart for operation

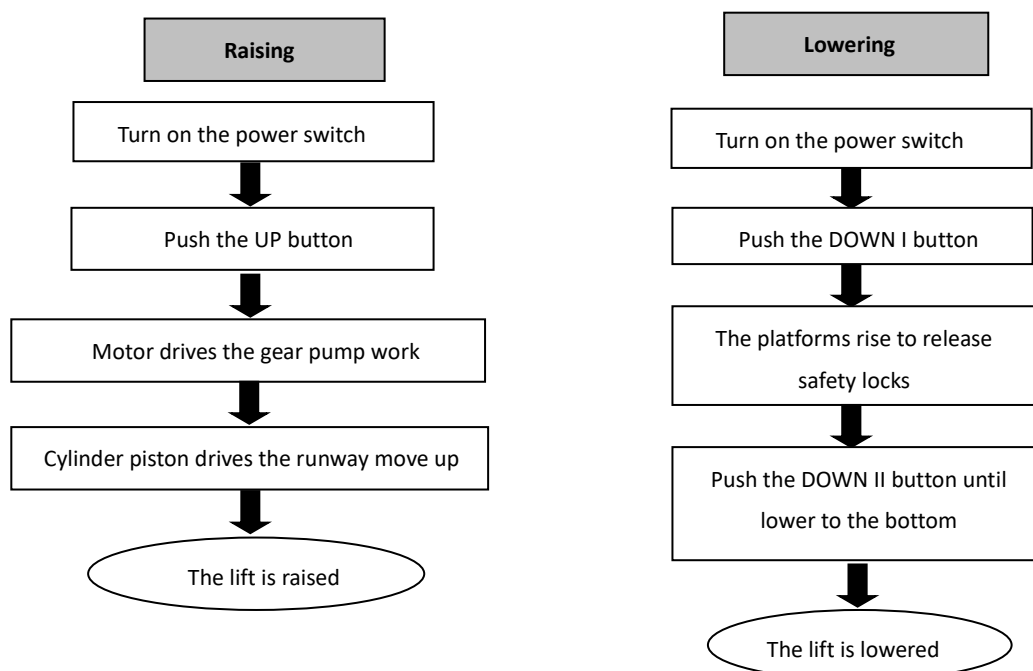

5.4 Operation instructions

The lift must be only used in a static position for lifting and lowering vehicles.

Only use this lift on a surface that is stable and capable of sustaining the load. Do not install the lift on any asphalt surface.

To avoid personal injury and/or property damage, permit only trained personnel to operate the lift. After reviewing these instructions, get familiar with lift controls by running the lift through a few cycles before loading vehicle on lifting platform.

Never raise just one end, one corner or one side of vehicle.

Turn SA3 to WORKING mode and turn on SA2 before normal use. The normal users are not allowed to open the door of control cabinet.

5.4.1 Lift with the wheel-support platform

Max. Capacity: 5000KG

Park the vehicle to be lifted on the platform correctly, making it is positioned against rolling and its steering lock off

Make sure the platform is neither loaded too heavy at front nor at rear and center of balance shall be in the moving scope of support arms.

Raising

1. Turn on the main power switch.
2. Drive and park the vehicle midway between two platforms.
3. Push the "UP" button to raise the vehicle a bit off the ground and check again the stability of the vehicle.
4. Having raised the vehicle to the expected height, push the "Safety Lock" button to ensure the mechanical safety lock is engaged.
5. Check again the stability before performing maintenance or repair work.

Lowering

When lowering the lift, pay careful attention that all personnel and objects are kept clear.

1. Push the DOWN I button to lower the lifting platform. It will stop lowering at safety height.
2. Push DOWN II button to continue lowering the platforms which accompanies with an audible warning.
3. Having been lowered completely, remove rubber pads and other tools to provide an unobstructed exit for moving vehicle from the lift area.
4. Drive the vehicle away.

Attention: In case of excessive height deviation between the two platforms, the synchronization protection device will be activated to stop any raising or lowering movement. In this case the normal operator needs to ask professional help from maintenance operator to restore the lift to normal working condition.

Methods for restoring the lift to run normally.

Open the door of the control cabinet;

Turn SA2 to OFF mode;

PUSH DOWN I and DOWN II button to fully lower the platform;

Level until both platforms are synchronized. (Refer to Step 8: Levelling)

Turn SA2 to ON mode.

5.4.2 Lift with the wheel-free platform

Max. Capacity: 4000KG

Raising

1. Turn the selection switch (SA1) on the control panel to wheel-free platform.
2. Place rubber pads under the pick-up points of vehicle. When it is necessary to use the platform extensions, push "UP" button to raise platforms of the jack a bit over the platforms of main lift and pull out the extensions.
3. Push "UP" button and check again if the rubber pads are directly under the pick-up points of the vehicle, when they are going very close to the vehicle's chassis.
4. Keep on pushing "UP" button until it reaches to the expected height. Full rise of the jack is 450mm over the platform of main lift.

Lowering

Attention: in case the platform extensions are used, the operator needs to retract both extensions when four wheels of vehicle get contact with wheel-support platforms.

1. Turn the selection switch (SA1) on the control panel to wheel-free platform.
2. Push "DOWN I" button on the control panel to lower the jack.
3. Take away rubber pads.

5.4.3 Use the play detector

Turn the selection switch (SA1) on the control panel to the mode of PD

The PD is designed for powered moving the wheels of the vehicle enabling inspection of suspension and steering joints.

1. Park the vehicle making its front wheels stay centrally on the PD plates, steering lock off and engine running (to enable the power steering system)
2. Raise wheel-support platform to a suitable working height to enable you to clearly view the suspension / steering joints to be inspected and park the lift into the mechanical locking system.
3. Using either the inspection torch or the key fob.

KEY fob

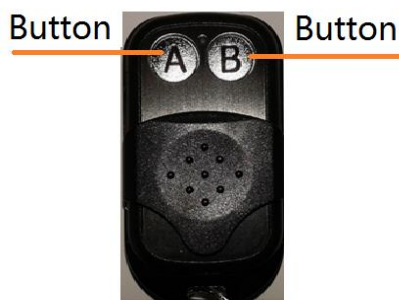

Inspection Torch



Button Button

Pressing and holding the one of the two buttons will operate the two PD plates at same time.

Attention: Allow to charge for 3 hours before initial use, always replace the torch back to its holder to have it charged when not in use.

Attention: The remote control works within a radius of 5.7m from the main control cabinet.

TROUBLE SHOOTING

ATTENTION: If the trouble could not be fixed by yourself, please do not hesitate to contact us for help. We will offer our service at the earliest time we can. The troubles will be judged and solved much faster if you could provide us more details or pictures of the trouble.

TROUBLES	POSSIBLE CAUSES	SOLUTIONS
Motor does not run and will not raise.	Damaged max-rise limit switch or its wire is disconnected.	Reconnect the wire or the replace with a new limit switch.
	Synchronization protective device is activated.	Turn off the overriding switch and level the platforms.
	Damaged buttons for raising or lowering. Disconnected wires.	Reconnect the wire or replace with a new button.
	Burnt-out motor.	Replace with a new motor.
Motor runs but will not raise.	The motor run reversely due to phase-sequence error.	Correct the phase-sequence.
	The corresponding solenoid valve does not work electrically.	Check the corresponding wire connection. (Pos.3 in the exploded scheme, coded as YV6 or YV8 in the electrical scheme)
	The corresponding solenoid valve is jammed.	Clean the valve. (Pos.3 in the exploded scheme, coded as YV6 or YV8 in the electrical scheme)
	Damaged cushion valve.	Replace with a new cushion valve. (Pos.12 on the exploded scheme)
	Damaged gear pump. (Pos.13 on the exploded scheme)	Replace with a new gear pump.
	Loose relief valve on the hydraulic block or the valve is jammed.	Tighten or clean the valve.
	No hydraulic oil or insufficient hydraulic oil.	Add enough oil.
	Untightened hose-connectors or ruptured hoses.	Tighten corresponding hose-connectors. Replace the ruptured hoses. NO.1 hose for the wheel-support platform, No.1,2 and 5 hose for the wheel-free platform in the scheme)
Platforms go down slowly after being raised.	Damaged non-return valve.	Replace it.
	Loose-installed solenoid unloading valve on the hydraulic block or the valve is jammed and leaked.	Tighten the valve. Clean the valve. (Pos.7 in the exploded scheme)
	Untightened hose connectors or leaking hoses.	Tighten corresponding hose-connectors. Replace the hoses. (NO.1 hose for the wheel-support platform, No.1,2 and 5 hose for the wheel-free platform)

TROUBLES	POSSIBLE CAUSES	SOLUTIONS
Raising too slow.	Over-worn gear pump	Replace with a new pump.
	Loose oil-sucking pipe	Tighten the pipe.
	Jammed filter	Clean or replace it.
	Unclean and old hydraulic oil	Change with fresh oil.
Lowering too slowly.	Jammed oil hose Any of the connector of for the above hoses was deformed.	Clean or replace it. (No.1 hose for wheel-support platform, No.1,2 and 5 hose for the wheel-free platform)
	Jammed connector of the master cylinder	Clean or replace it. (Connector D in the scheme).
	Jammed solenoid unloading valve.	Clean or replace it.
PD fails to run	Jammed or squeezed oil hose.	Clean the hose. Replace the hose.
	The valve for shifting Lift to PD failed to work due to no electricity or damage.	Check the wire connection. Replace with a new valve. (No.10 hose on the oil hoses scheme for PD).
	Poor contact of the selection switch for PD and Lift function or the selection switch is damaged.	Check the wire connection. Replace with a selection switch.
	Solenoid valve for PD does not work (due to no electricity or damage).	Check the wire connection. Replace with a new valve.
	Any of oil hose for PD system is leaked.	Check the hoses and replace the leaking hose.

MAINTENANCE

Easy and low cost routine maintenance can ensure the lift work normally and safely.

Following are requirements for routine maintenance.

Follow the below routine maintenance schedule with reference to the actual working condition and frequency of your lift.

Lubricated moving parts with NO.1 lithium grease before use.

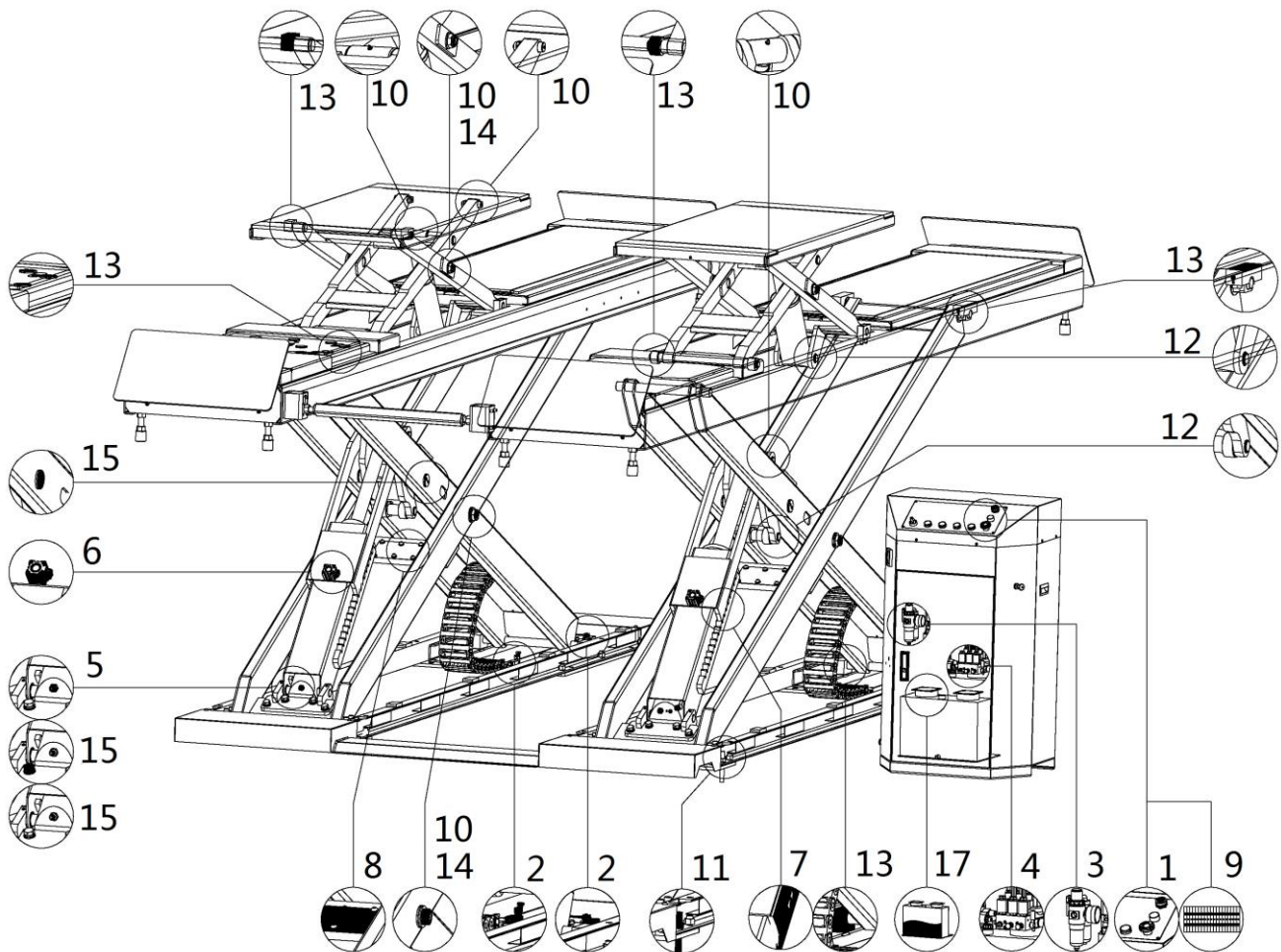

S/N	Components	Methods	Period
1	Control buttons	Check if control buttons work as "hold- to -run " and check if they work as the function indicated.	Every day
2	Max height limit switch	Push the UP button, inspect and ensure the lifting platform stops rising at maximum lifting height.	Every day
3	Pneumatic filter	Listen and inspect the filter to ensure no leakage. Inspect and ensure the water level is below its max limit mark and the oil level is above the minimum limit mark.	Every day
4	Hydraulic block and valves	Inspect if the valves leak or not. Clean or change the valve if any leakage.	Every day
5	Oil hoses and connectors	Inspect to ensure no leakage before using the lift.	Every day

S/N	Components	Methods	Period
6	Pneumatic hoses and connectors	Inspect to ensure no leakage before using the lift.	Every day
7	Mechanical safety catch	Check if both mechanical catches can engage and disengage effectively and synchronously by pushing control buttons.	Every day
8	Padding plate for the start roller	Check its tightness and add grease.	Every 1 month
9	Terminals in the control unit	Open the control unit, inspect the wire terminals and tighten them if any terminals had become loose.	Every 3 months
10	Joint shafts	Add grease into the oil cups.	Every 3 months
11	Anchored expansion bolts	Check with torque spanner. Screw torque:80Nm	Every 3 months
12	Circlip on the shaft	Check and ensure it is in the slot of the shaft.	Every 3 months
13	Sliding blocks	Add grease onto the tracks for sliding blocks	Every 3 months
14	Self-locking nut	Check with torque spanner. The torque should be no less than 330N.m.	Every 3 months
15	Fixation holder of the wheel free jack	Check with torque spanner. The torque should be no less than 55N.m.	Every 3 months
16	Lifting platform synchronization	Check the synchronization of both lifting platforms. Ensure both platforms ascend and descend synchronously.	Every day
17	Hydraulic oil	Change the oil 6 months after initial use and once per year thereafter. Inspect the hydraulic oil and change the oil if the oil becomes black or there is dirt in the oil tank.	Every year
18	Whole Lift	Running the lift for several cycles with and without rated load. The lift can run steadily and smoothly with no abnormal noise. Check the synchronization of both lifting platforms. Ensure both platforms ascend and descend synchronously.	Every 3 months

If users stick to the above maintenance requirements, the lift will always keep a good working condition and its service life could be extended.

Annex 1, Floor Plan

Requirements:

C25-C30 concrete base with a minimum thickness of 250mm.

Surface: Horizontal and even (Gradients under the base plate max. 0.5 %)

Newly built concrete ground must be older than 20days.

Floor Plan for recessed installation

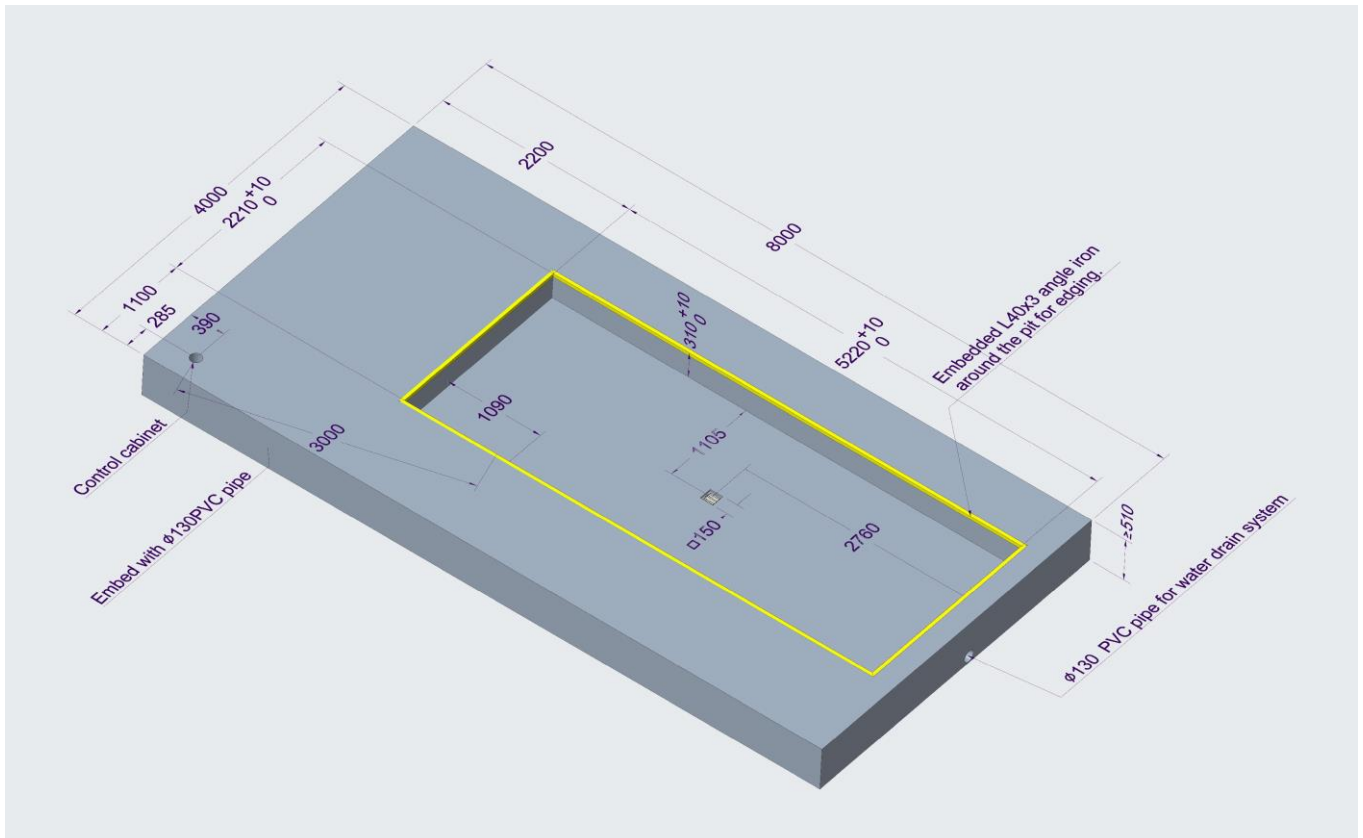

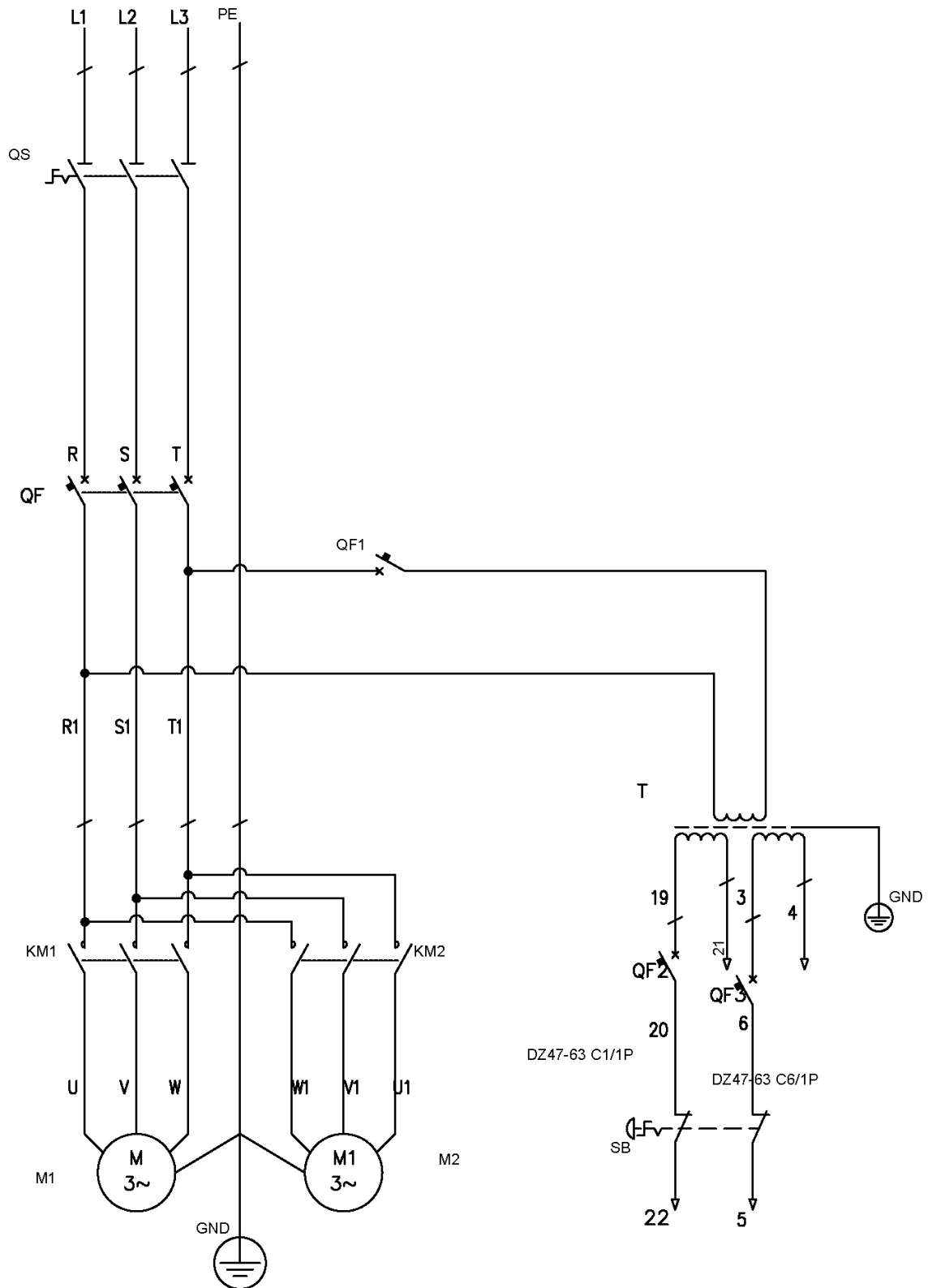
Annex 2, Electrical schemes and parts list

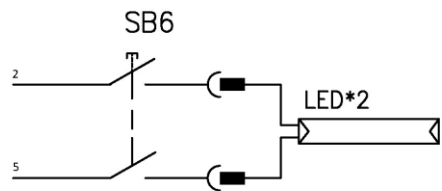
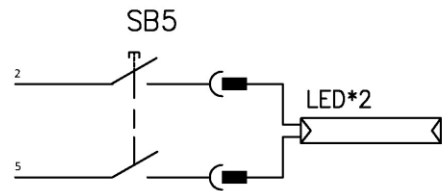
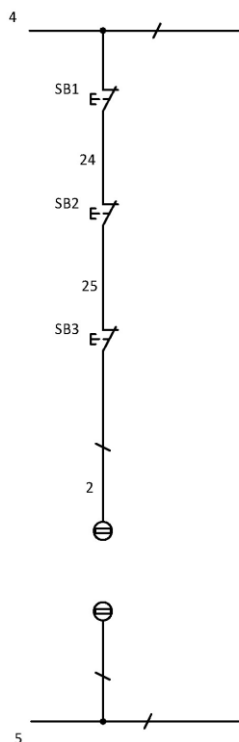
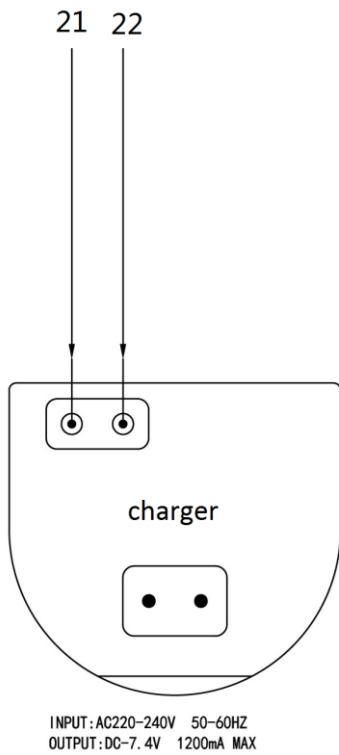
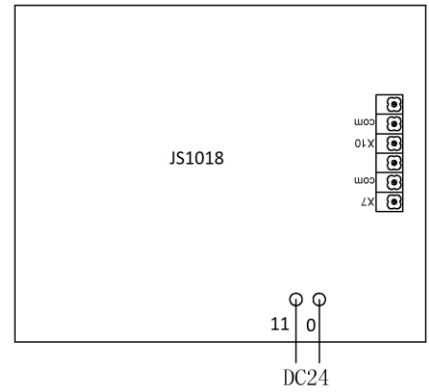
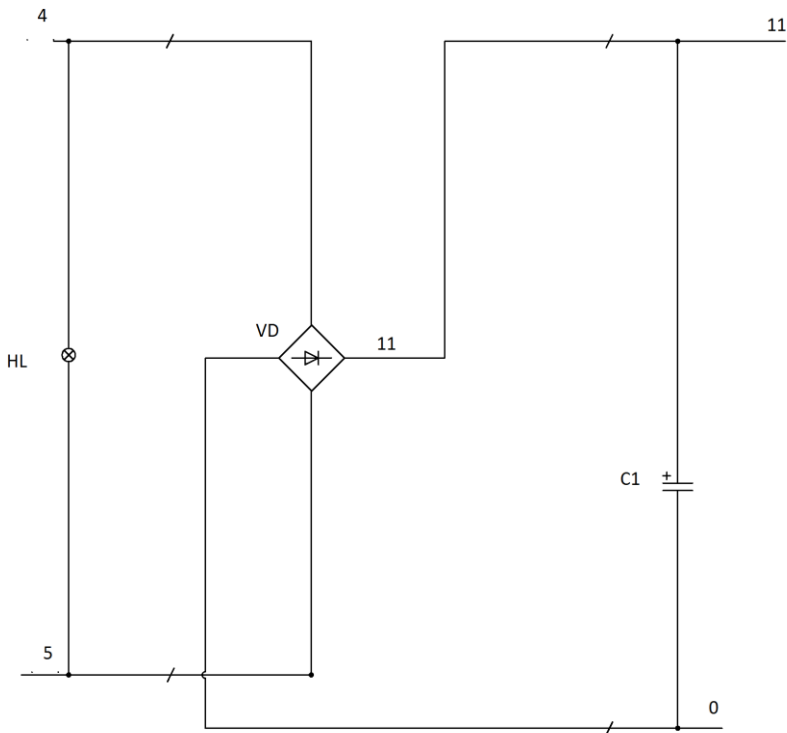

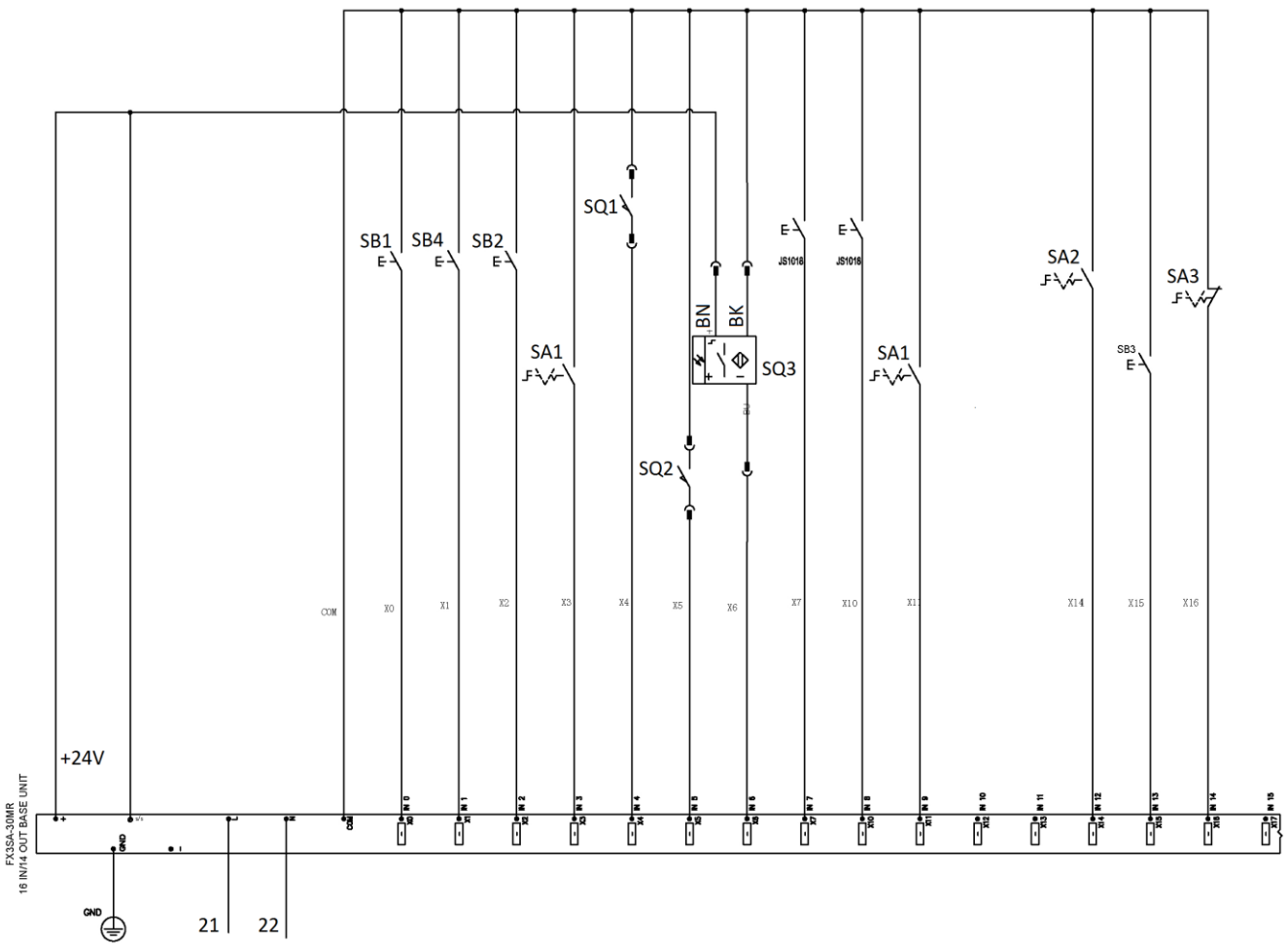

Update the following diagram

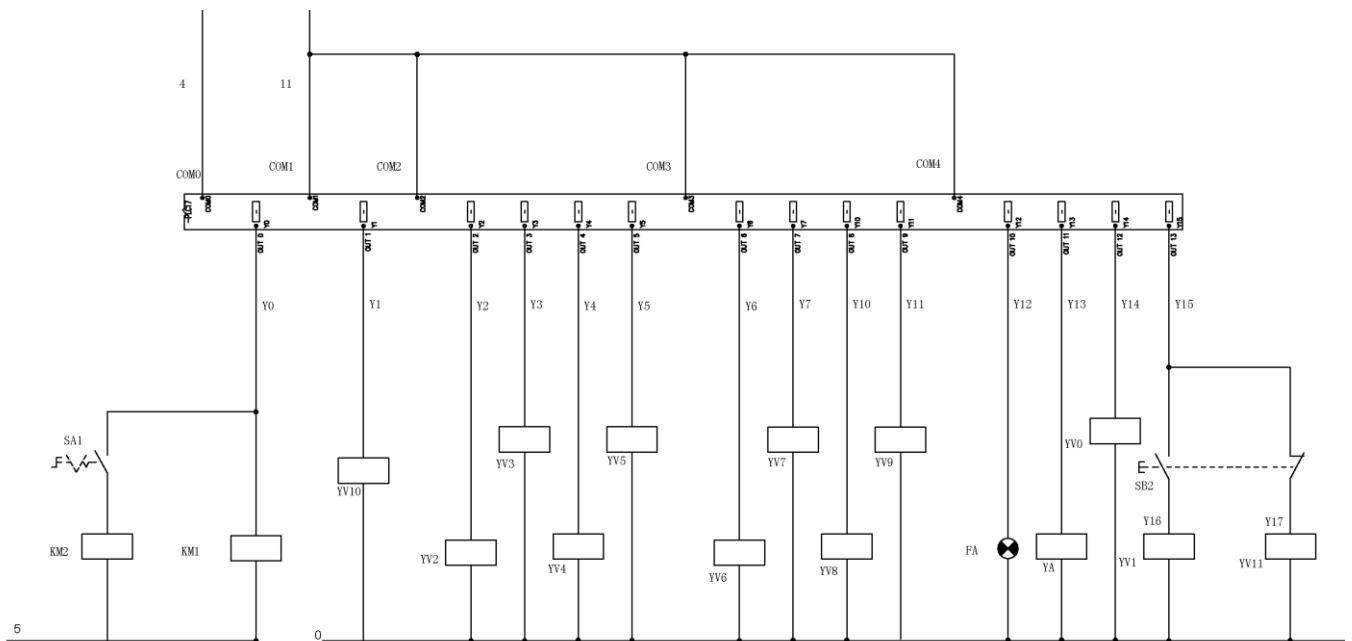

Update the following diagram

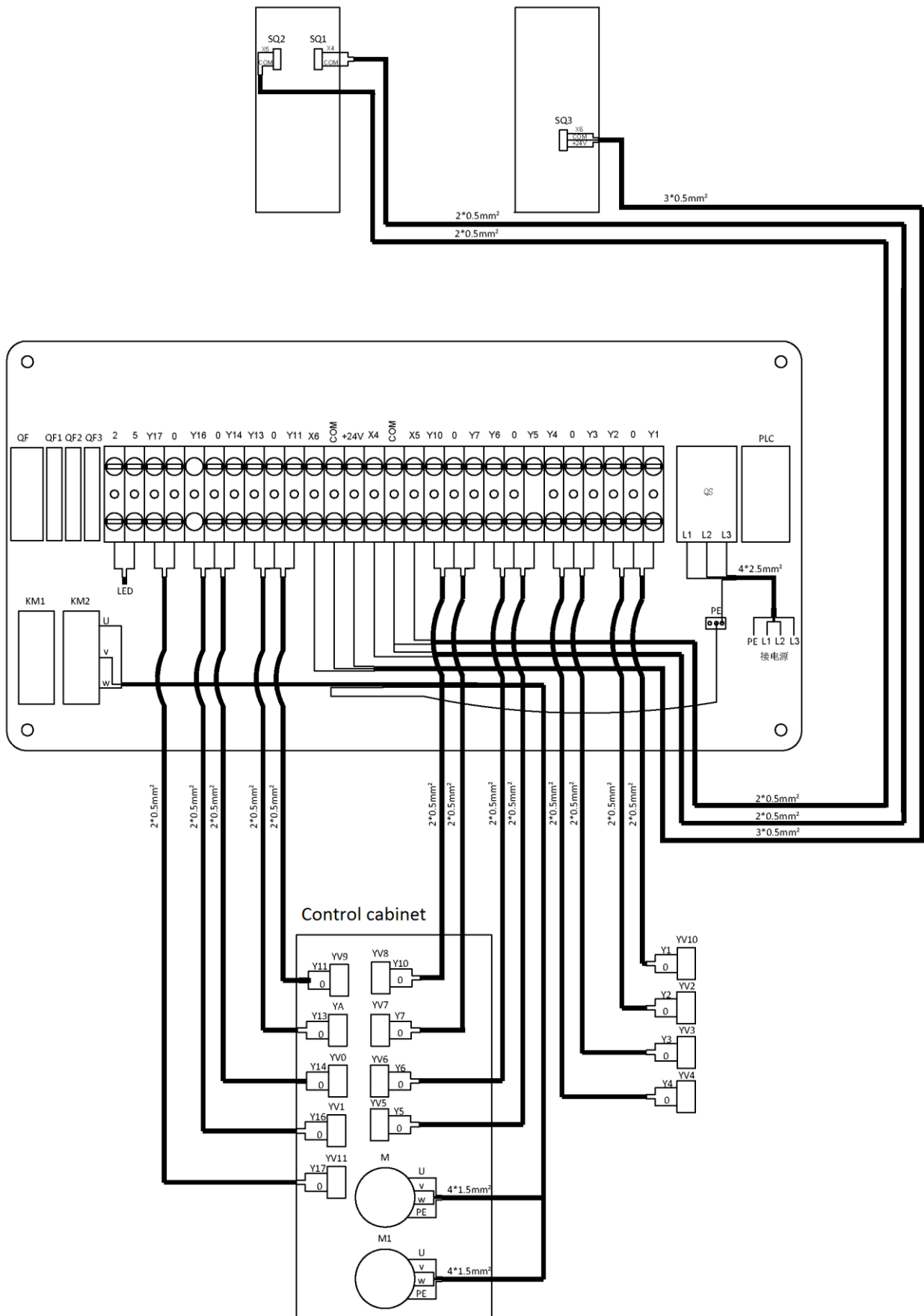



SQ1	Limit switch for max rise	YV4	Solenoid valve for PD
SQ2	Limit switch for safe descent	YV5	Solenoid valve for PD
SQ3	Photoelectric switch	YV6	Solenoid valve for the main lift
YA	Pneumatic solenoid valve	YV7	Levelling solenoid valve for the main lift
YV0	Solenoid unloading valve 1	YV8	Solenoid valve for the wheel-free lift
YV1	Solenoid unloading valve 2	YV9	Levelling solenoid valve for the wheel-free lift
YV2	Solenoid valve for PD	YV10	Solenoid valve for shifting lifting to PD
YV3	Solenoid valve for PD		

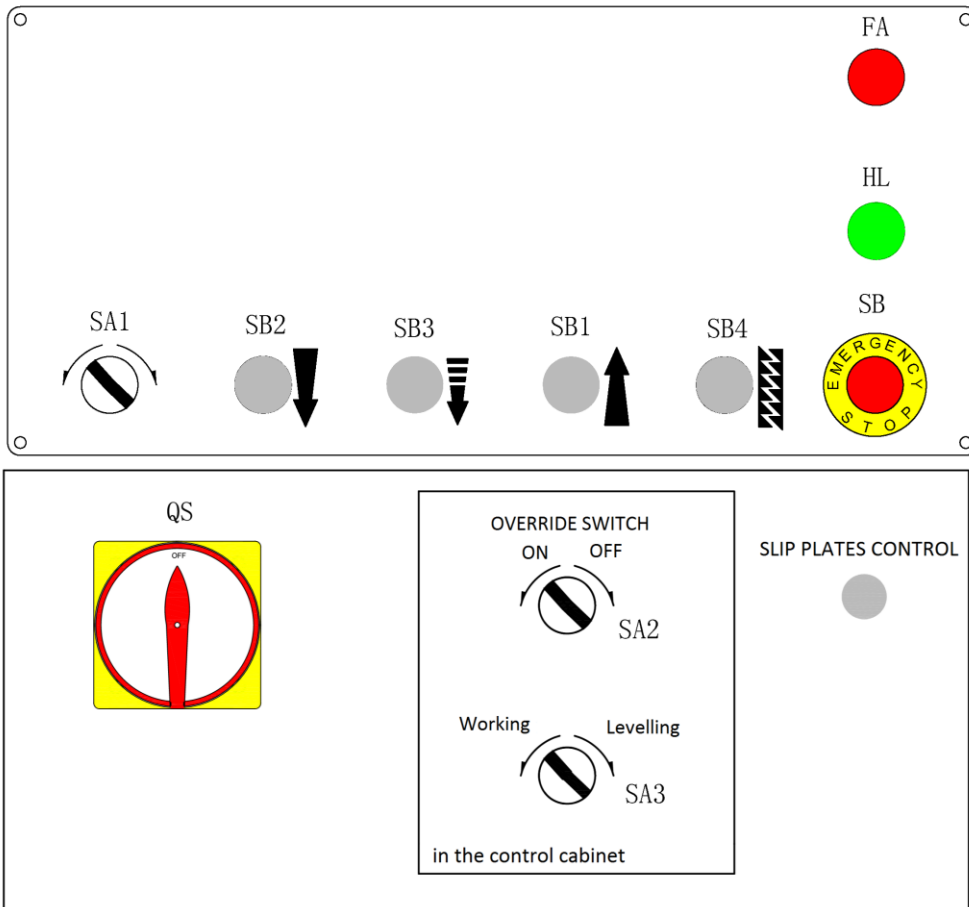

Code in the scheme	P-code	Description	Specification	Qty
T	320104104	Transformer	JBK5-160VA 380V400V415V-220V40VA 24V120VA	1
QF	320801003	Circuit breaker(3Ph)	CDB6iC25/3P (CB-60A C25)	1
QF1	320803003	Circuit breaker(3Ph)	CDB6iC3/1P	1
QF2	320803001	Circuit breaker	CDB6iC1/1P (CB-60A C1)	1
QF3	320803005	Circuit breaker	CDB6iC6/1P(CB-60A C6)	1
KM1 KM2	320901011	AC contactor	CJX2-1810/AC24V(CDC6i-1810/AC24V)	2
QS	320304001	Power switch	LW26GS-20-04	1
SQ1 SQ2	320301011	Limit switch	TZ8108	2
SQ3	320306025	Photoelectric switch	CGY18E-R2NA	1
SA1	320303023	Selection switch (3P)	NP2-ED38C	1
SA2 SA3	320303018	Selection switch (2P)	NP2-ED23C	2
SB1 SB2 SB3 SB4	320401041	Button	NP2-EA15 (CDLA6H-EA15)	4
SB	320402010	Stop button	NP2-BS544(CDLA6H-BS544)	1
PLC	321301004	PLC	FXIS(3SA)-30MR16in14out	1
	321003005	Remote control (key fob)	1027DC12V	1
	793220006	Remote control (with torch and charger)		1
JS1018	321003007	Receiver	JS1018 DC24V	1
C	321001004	Capacitor	4700UF/50V	1
VD	321002001	Bridge rectifier	KBPC5A-35A	1
HL	321201001	Indicating lamp	ND16-22DS-2	1
FA	321202001	Alarm buzzer	AD118-22SM/R/AC/DC/24V	1
SB5 SB6	320307034	Metal button	LANB00(22mm AC24V)	2
LED	321201021C	Led lamp	AC24-15W-16cm	4

NOTE: For power supply of other voltages, the transformer is different.

Please check with our customers service people when order spare parts.

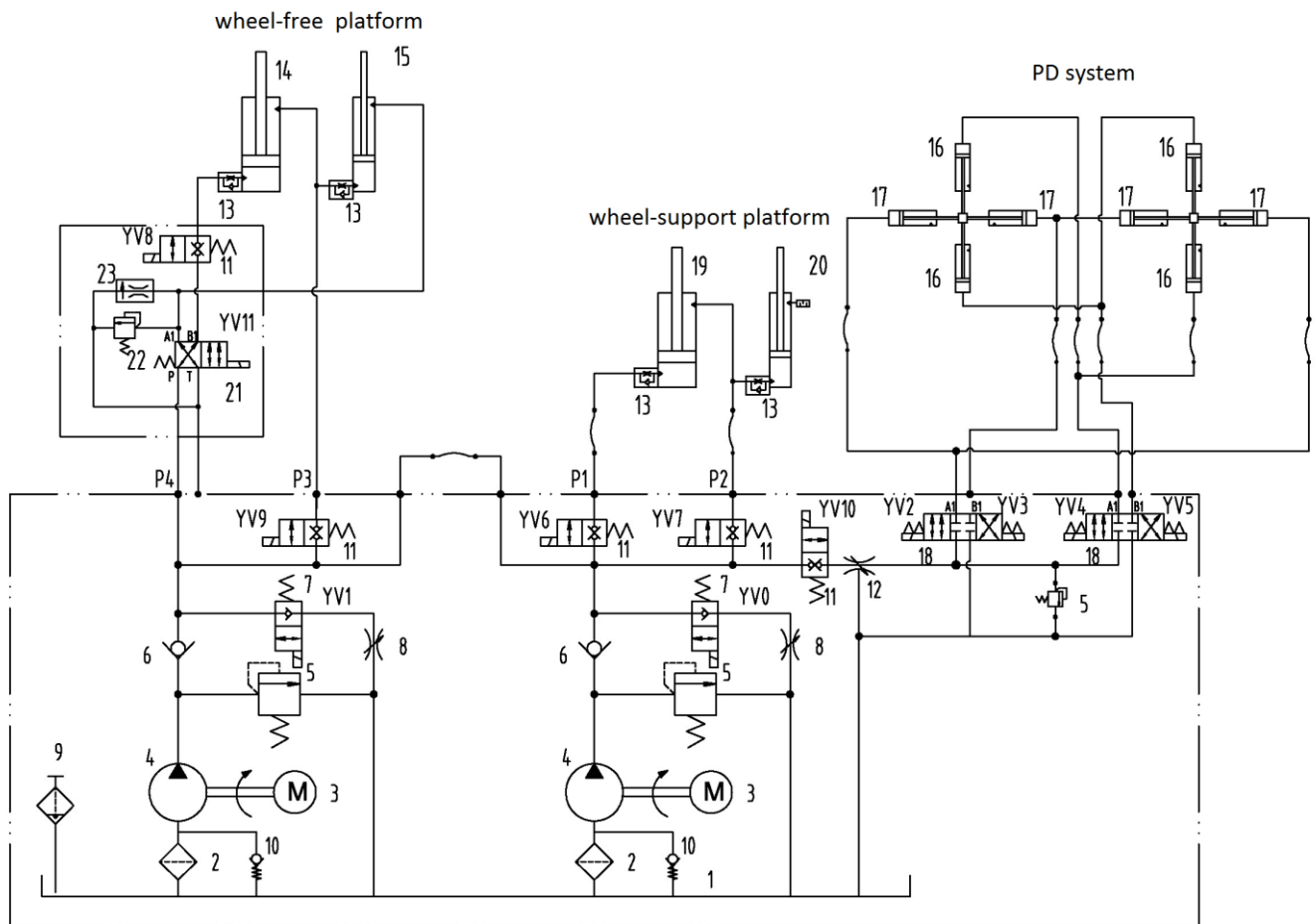
Annex 3, Hydraulic schemes and parts list

- | | | | |
|----|-----------------------------------|----|---|
| 1 | Steel oil tank | 11 | Valve spool for the solenoid valve |
| 2 | Filter | 12 | Restrictive valve |
| 3 | Motor | 13 | Straight connector with restrictive valve |
| 4 | Gear pump | 14 | Master cylinder of WF |
| 5 | Relief valve | 15 | Slave cylinder of WF |
| 6 | Non-return valve | 16 | PD cylinder |
| 7 | Solenoid unloading valve assembly | 17 | PD cylinder |
| 8 | Restrictive valve | 18 | Solenoid valve (3P4W) |
| 9 | Oil tank lid | 19 | Master cylinder of WS |
| 10 | Cushion valve | 20 | Slave cylinder of WS |
| 21 | Solenoid valve | 22 | Relief valve |
| 23 | Pressure compensating valve | | |

The following hydraulic lines are for control cabinet positioned on the left side (face the cabinet at the rear end of the platform).

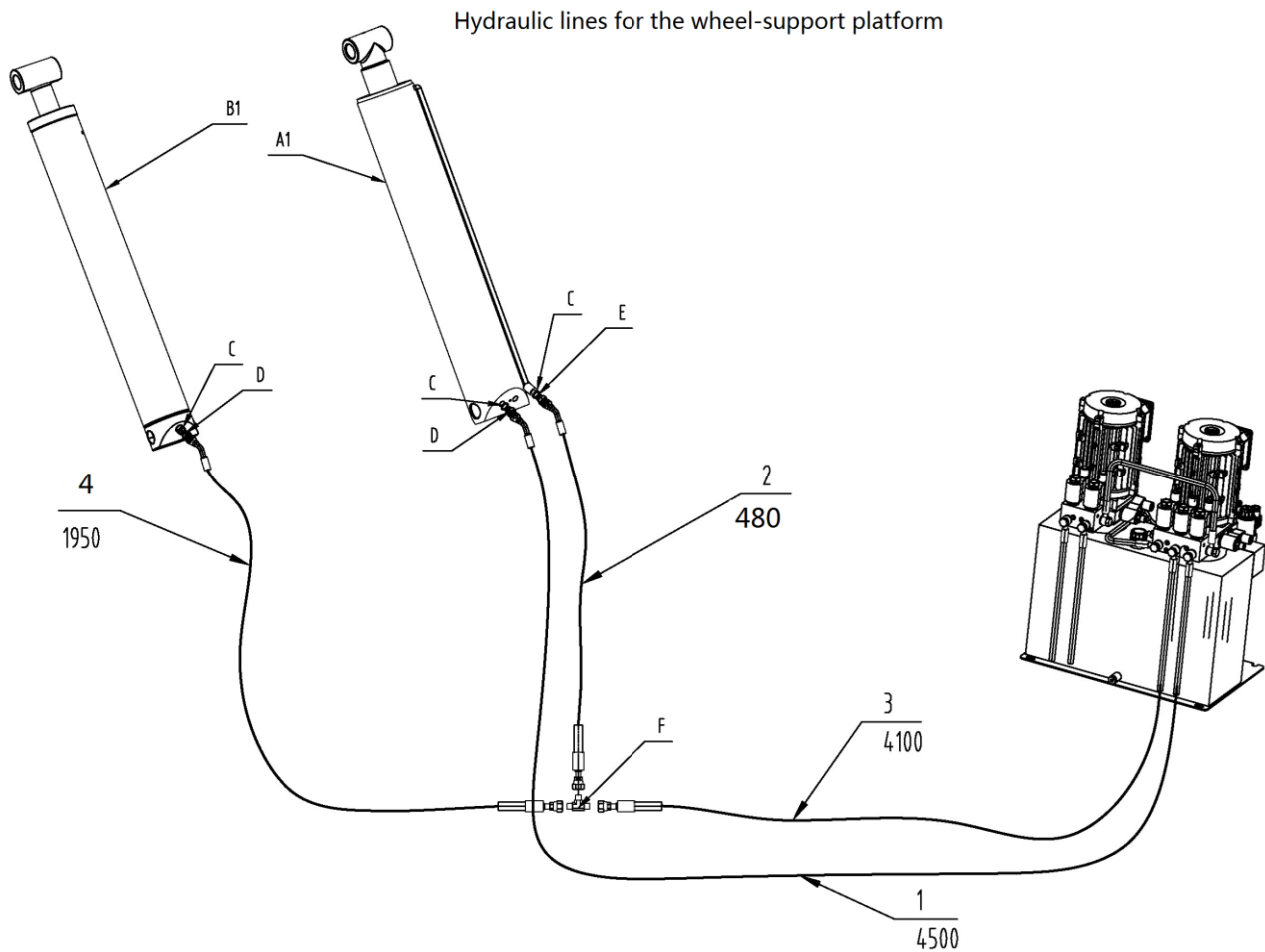

Pos.	Code	Component descriptions	Specification	Qty
1	624008156	Oil hose	L=4500mm	1
2	624008157	Oil hose	L=480mm	1
3	624008158	Oil hose	L=4100mm	1
4	624008159	Oil hose	L=1950mm	1
A1	615068516	Master cylinder	YG120-140-67-645	1
B1	615068517	Slave cylinder	YG100-114-50-645	1
C	207103025	Composite washer	13_7X20X1_5	3
D	330305009	Straight connector with restrictive valve	BDPF-G14-G14-I60	2
E	310101010	Straight connector	G1/4---G1/4	1
F	410210181	Three-way connector	6603B-A9-B7	1

Hydraulic lines for the wheel-free platform

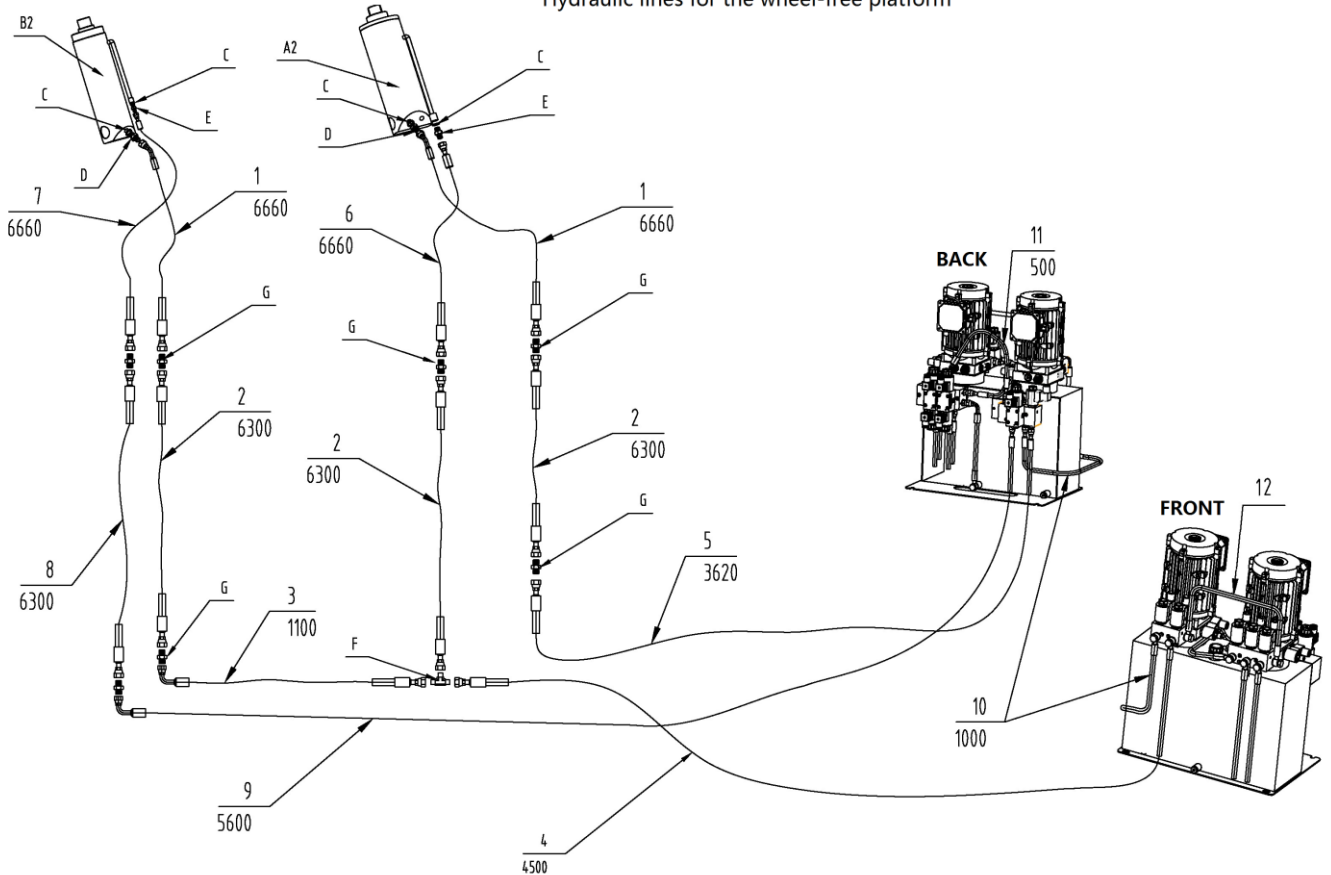

Pos.	Code	Component descriptions	Specification	Qty
1	624008161	Oil hose	L=6660mm	2
2	624008163	Oil hose	L=6300mm	3
3	624008166	Oil hose	L=1100mm	1
4	624008165	Oil hose	L=4500mm	1
5	624001128	Oil hose	L=3620mm	1
6	624008162	Oil hose	L=6660mm	1
7	624008248	Oil hose	L=6660mm	1
8	624008249	Oil hose	L=6300mm	1
9	624008189	Oil hose	L=5600mm	1
10	624008250	Oil hose	L=1100mm	1
11	624008251	Oil hose	L=600mm	1
12	624008160	Oil hose	L=650mm	1
A2	615026701	Master cylinder	HX6-SMICYL	1
B2	625000040	Slave cylinder	YG80-95-45-150-KS	1
C	207103025	Composite washer	13_7X20X1_5	4
D	330305009	Straight connector with restrictive valve	BDPF-G14-G14-I60	2
E	310101010	Straight connector	G1/4---G1/4	2
F	410210181	Three-way connector	6603B-A9-B7	1
G	410210191	Straight connector	6603B-A9-B8	7

Hydraulic lines for the PD system

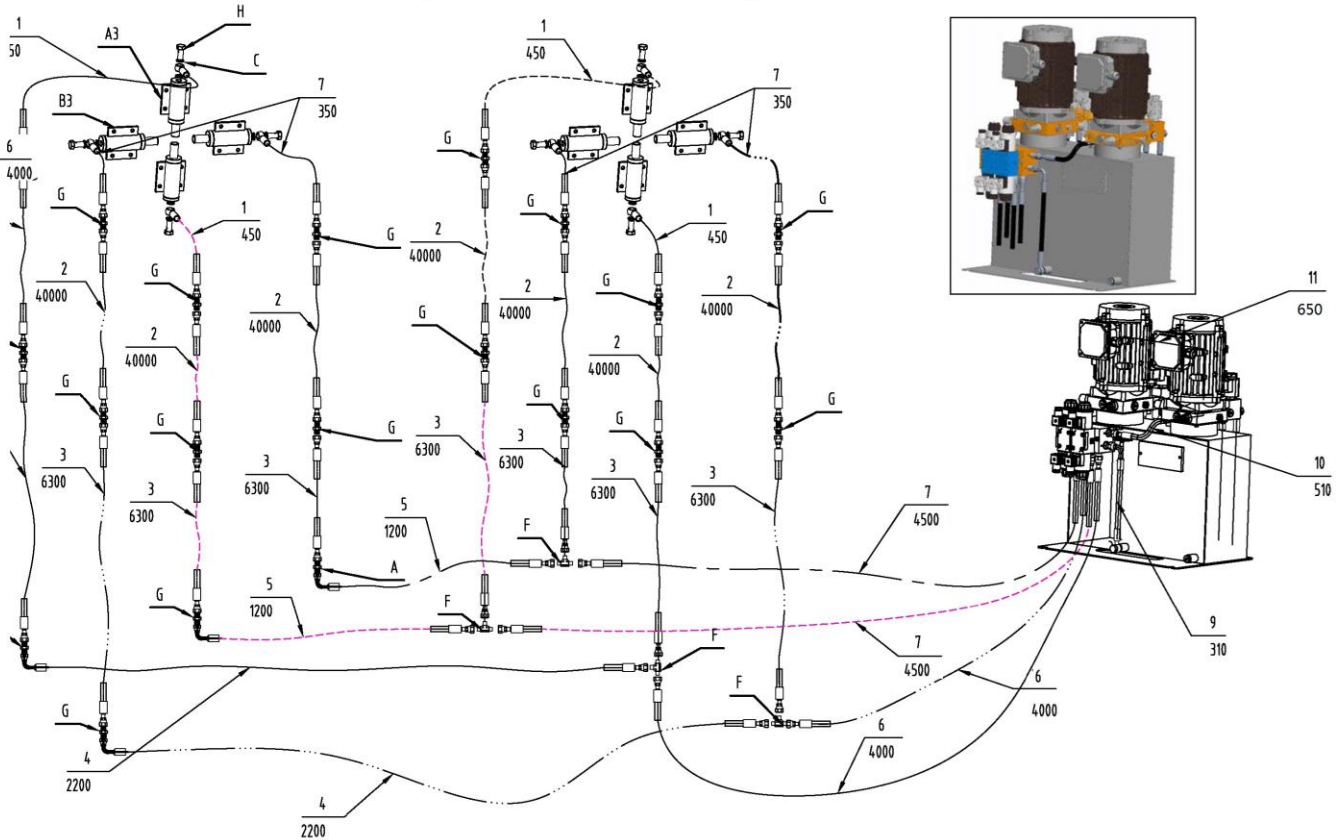

Pos.	Code	Component descriptions	Specification	Qty
1	624008168	Oil hose	L=450mm	4
2	624008169	Oil hose	L=4000mm	10
3	624008170	Oil hose	L=6300mm	8
4	624008172	Oil hose	L=2200mm	2
5	624008171	Oil hose	L=1200mm	2
6	624008164	Oil hose	L=4000mm	1
7	624008174	Oil hose	L=4500mm	2
8	624008167	Oil hose	L=350mm	4
9	624008175	Oil hose	L=310mm	1
10	624008176	Oil hose	L=510mm	1
11	624008160	Oil hose 650	L=650mm	1
A3	625000004	PD8 cylinder 1	YG30-40-20-53-59	1
B3	625000018	PD8 cylinder 2	YG30-40-20-53-70	1
C	207103025	Composite washer	13_7X20X1_5	16
F	410210181	Three-way connector	6603B-A9-B7	5
G	410210191	Straight connector	6603B-A9-B8	20



Hydraulic power unit

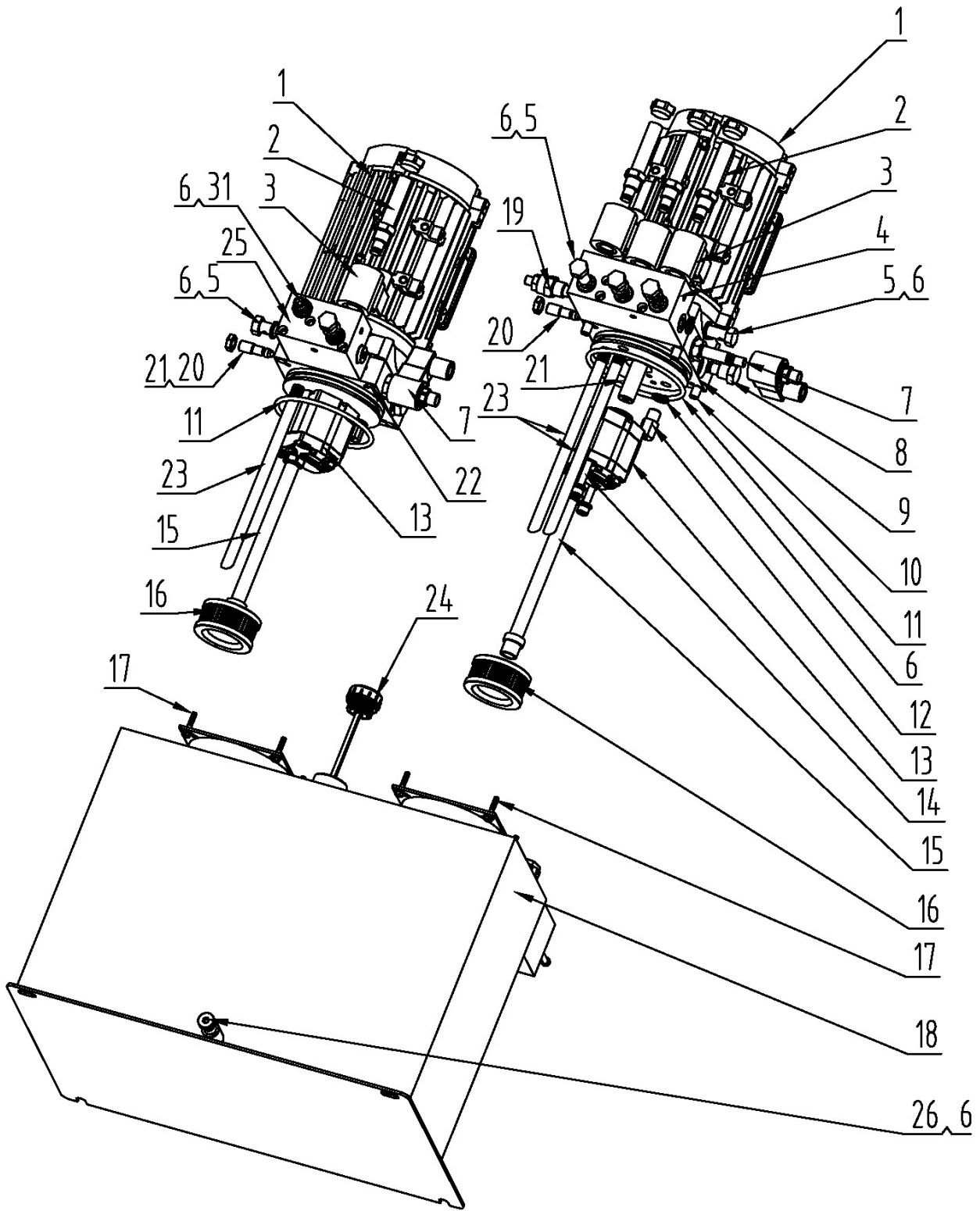

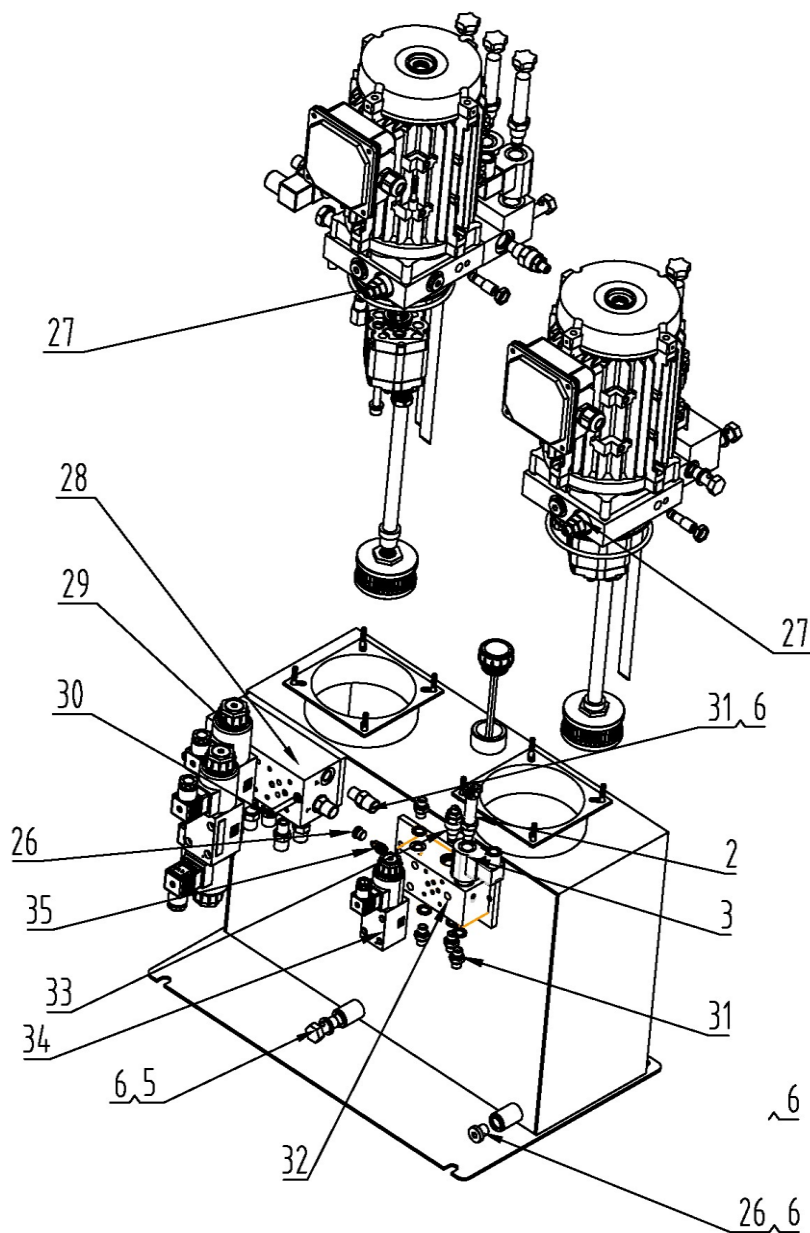

Pos.	Code	Component descriptions	Specification	Qty
1	320203001	Motor	380V-3.5KW-3PH-50HZ-2P	2
2	330308040	Valve spool for the solenoid valve	LSV-08-2NCSP-LM	5
3	330308039	Solenoid coil	HC-C-16-D24	5
4	330105038	Hydraulic block	LA50292	1
5	410281130	Cylinder connector	CJ-A12-B5-C10	8
6	207103025	Composite washer	13_7X20X1_5	16
7	791150005	Solenoid unloading valve assembly	DC24V	2
8	330302006	Non-return valve	DF08-01-00	2
9	330105039	Hydraulic block	LA50291	1

Pos.	Code	Component descriptions	Specification	Qty
10	202109064	Hex socket cylinder head screw	M6x30-GB70_1	8
11	207101166	Type O seal ring	110*5	2
12	202109144	Cushion valve	M5x18	2
13	330201015	Gear pump	CBK-F233-G	2
14	202109072	Hex socket cylinder head screw	M8x85-GB70_1	4
15	330401002	Oil-sucking pipe	YX-BL=230	2
16	330403001	Filter	YG-C	2
17	201103001	Hex flange head bolt	M5x25-GB5789	8
18	330405071	Steel oil tank	28L	1
19	330305022	Restrictive valve	LNV2-08	1
20	330305023	Restrictive valve	M12X1	1
21	330404007	Coupling	46mm (LBZ-T202BK-1)	2
22	330105041	Hydraulic block	LA10081	1
23	330402001	Oil-back pipe	YH-D	3
24	330502013	Oil tank lid	YBZ-BT-M30*2-B	1
25	330105075	Hydraulic block	LA50692	1
26	210101004	Hex socket flat head fitting	G1/4	1
27	330304007	Relief valve	YF08-40	2
28	330105042	Hydraulic block	LA10161	1
29	330308011	Solenoid valve (3P4W)	DHF06-340/DC24	2
30	202109026	Hex socket cylinder head screw	M6X60-GB70_1	2
31	310101010	Straight connector	G1/4---G1/4	6
32	330105076	Hydraulic block	LA50651-B	1
33	330304015	Relief valve	RV-08-36	1
34	330308051	Solenoid valve	4WE6Y6X/ED24LL	1
35	330308041	Pressure compensating valve	IFC-6T-4	1

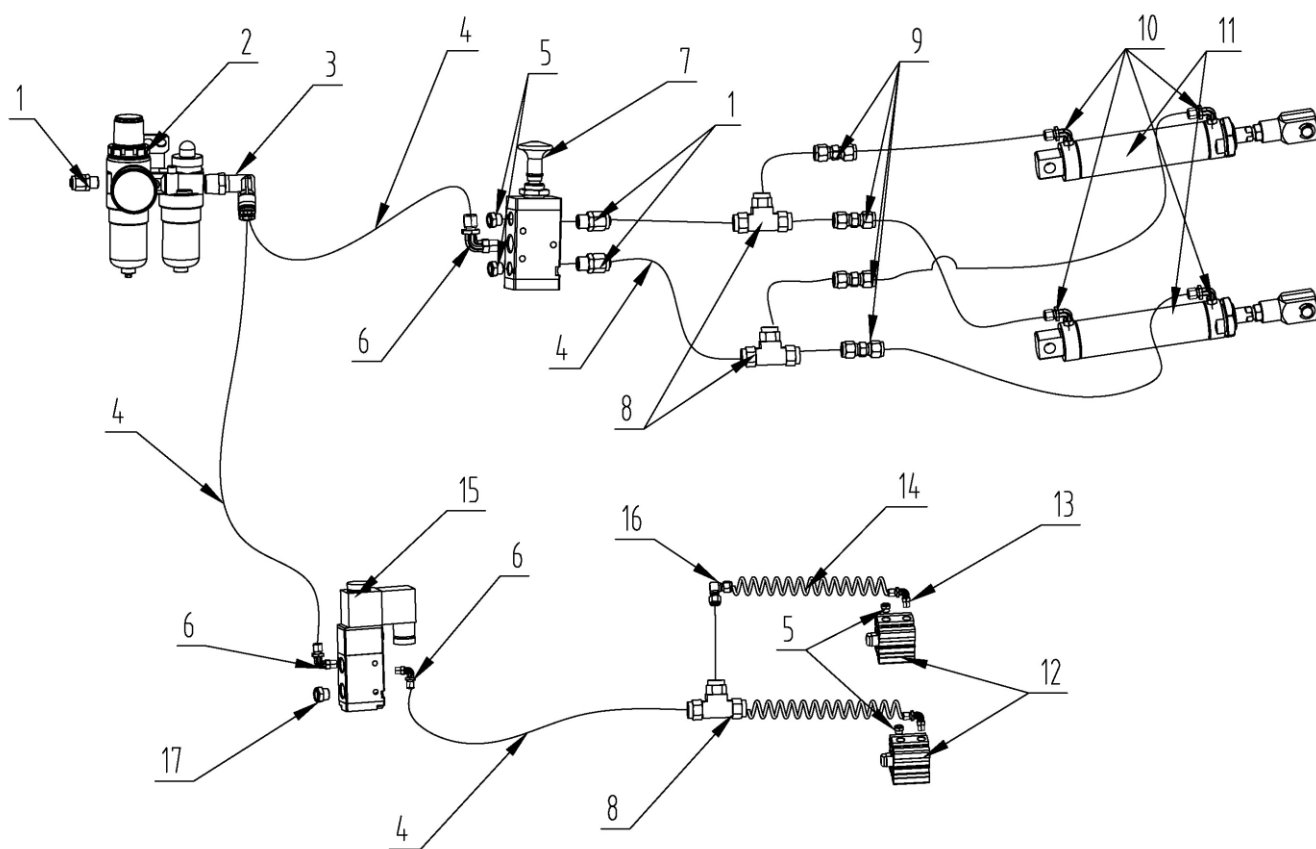
Annex 4, Pneumatic schemes and parts list

Pos.	Code	Component descriptions	Specification	Qty
1	310101015	Straight connector	KLC8-02	3
2	321004006	Air filter combination	AFC2000-M	1
3	310103008	Three-way elbow connector	PX8-M14S	1
4	123010201	Air hose	D=8	
5	310201003	Silencer	SLM01-R1-8	4
6	310102015	Elbow connector	KLL8-02	3
7	330301002	Pull valve	4L210-08	1
8	310103006	Three-way connector	KLE-8	3
9	310101055	Straight connector	KLU-8	4
10	310102024	Elbow connector	KLL8-01	4
11	310502001	Pneumatic cylinder	MA40X100SCA	2
12	310501001	Pneumatic cylinder	CQ2B32X20-A	2
13	310102024	Elbow connector	KLL8-01	2
14	310601001	Spiral hose	CL-0850-6 6M	1
15	310401001	Pneumatic solenoid valve	3V210-08DC24V	1
16	310102026	Elbow pneumatic connector	KLV-8	1
17	310201002	Silencer	SLM02-R1-4-M12	1

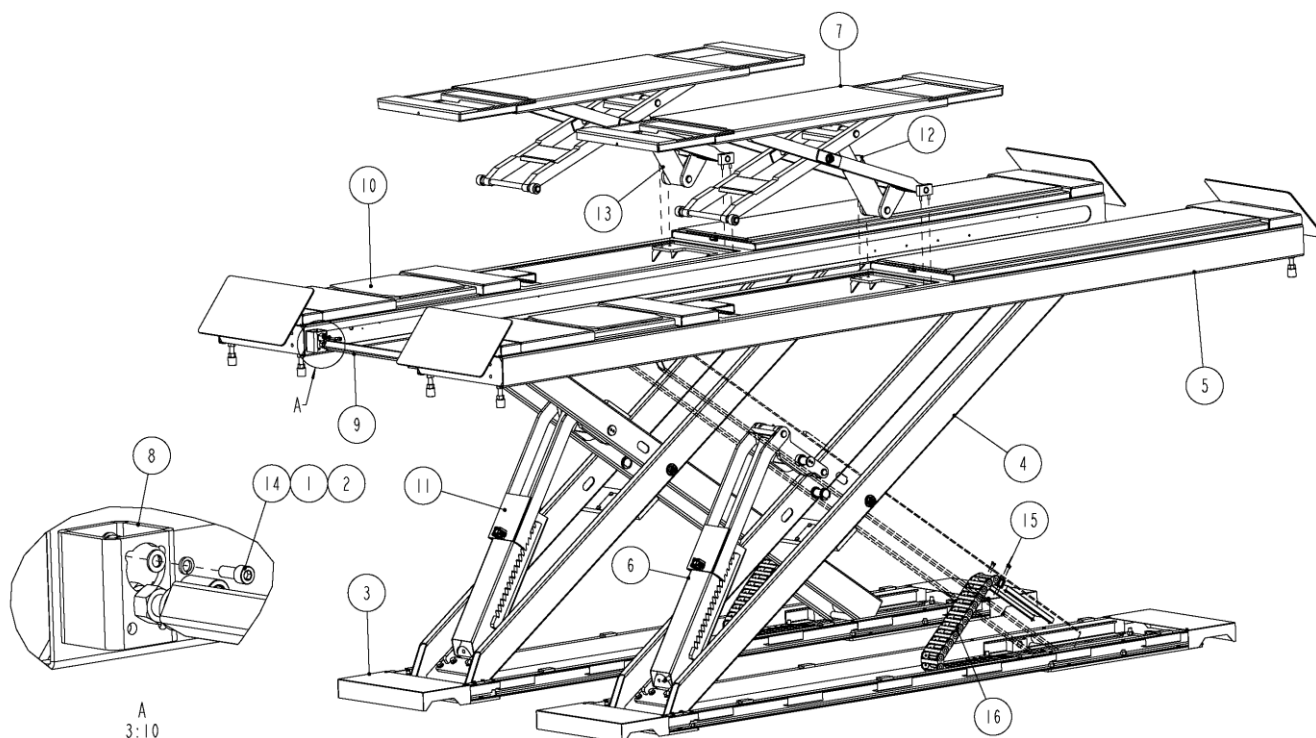
Annex 5, exploded drawings and parts list for the mechanical parts

Pos.	Code	Component descriptions	Specification	Qty
1	204201005	Spring washer	D10-GB93	8
2	204101006	Flat washer	D10-GB95	8
3	615068568	Base plate	HX50-A1	1
4	615068569	Support arm	HX50-A2	2
5	615068570	Platform A	HX50-A3	1
6	615068573	Master cylinder	HX50-A4	1
7	615068575	Wheel-free lift	HX50-A5	2
8	614901661	Holder for the support rod	HX50-A8	2
9	615068605	Middle support rod	HX50-A9	1
10	615068571	Platform B	HX50-A3B	1
11	615068574	Slave cylinder	HX50-A4B	1
12	615060140	Master cylinder of the wheel-free lift	HX6-A5	1
13	615060150	Slave cylinder of the wheel-free lift	HX6-A5B	1
14	202109042	Hex socket cylinder head screw	M10X25-GB70_1	8
15	202109007	Hex socket cylinder head screw	M5X8-GB70_1	16
16	208108013	Plastic chain cover	VBP31_F103_R55_N22	2

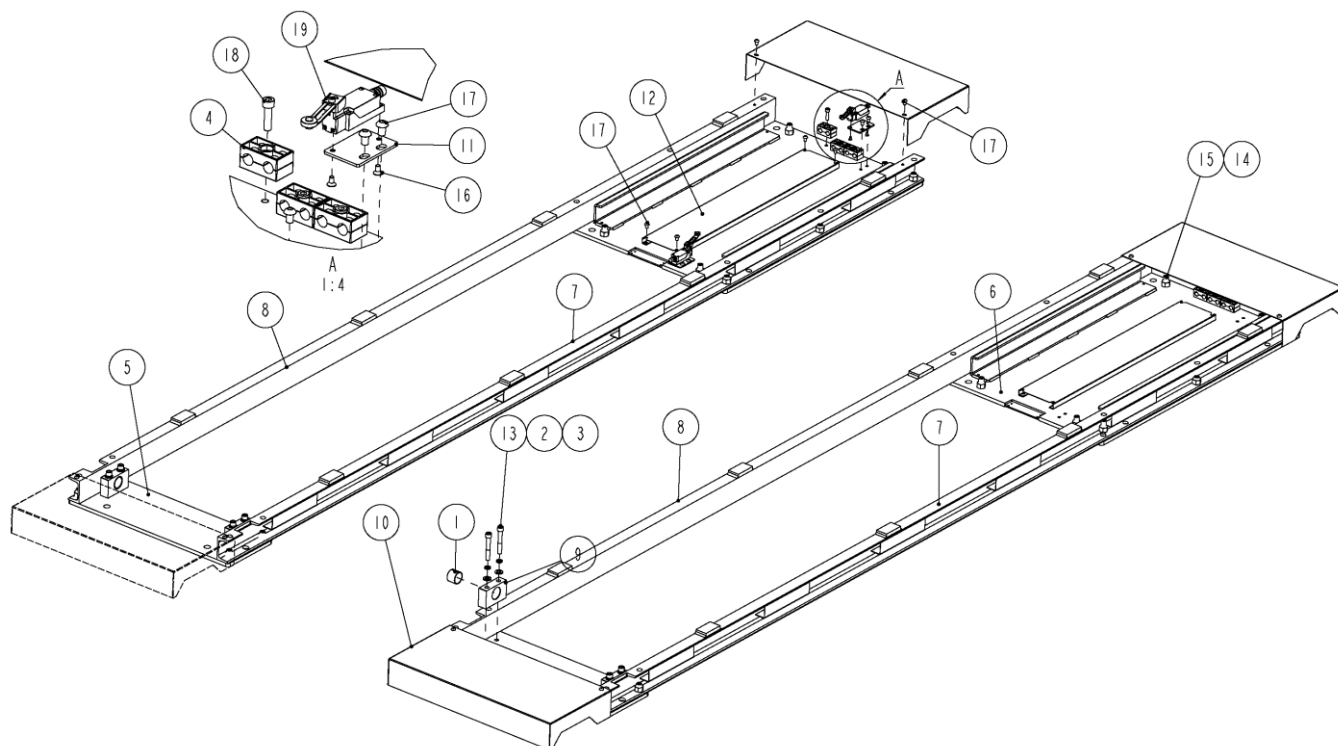

Pos.	Code	Component descriptions	Specification	Qty
1	205101109	Bearing	3530-SF-1X	4
2	204201006	Spring washer	D12-GB93	8
3	204101007	Flat washer	D12-GB95	8
4	208101039	Double-hole hose clamp	GJTXG1-214	6
5	410911254	Small base plate	HX50-A1-B1	2
6	614901627	Large base plate A	HX50-A1-B2	2
7	614901628	Connecting slot beam A	HX50-A1-B3	2
8	614901629	Connecting slot beam B	HX50-A1-B4	2
9	410911203	Bottom support holder	HX50-A1-B6	4
10	410911204	Base cover	HX50-A1-B7	4
11	410911381	Holding plate for limit switch	HX50-A1-B8	2
12	410911200	Oil hose cover	HX50-A1-B10	2
13	202109154	Hex socket cylinder head screw	M12X80-GB70_1	8
14	203101009	Type I hex nut	M16-GB6170	28
15	202205002	Flat head locking screw	M16X50-GB77	28
16	202111001	Hex socket flat head screw	M5X10-GB70_3	4
17	202110004	Hex socket button head screw	M8X12-GB70_2	20
18	202109031	Hex socket cylinder head screw	M8X30-GB70_1	6
19	320301011	Limit switch 8108	TZ8108	2

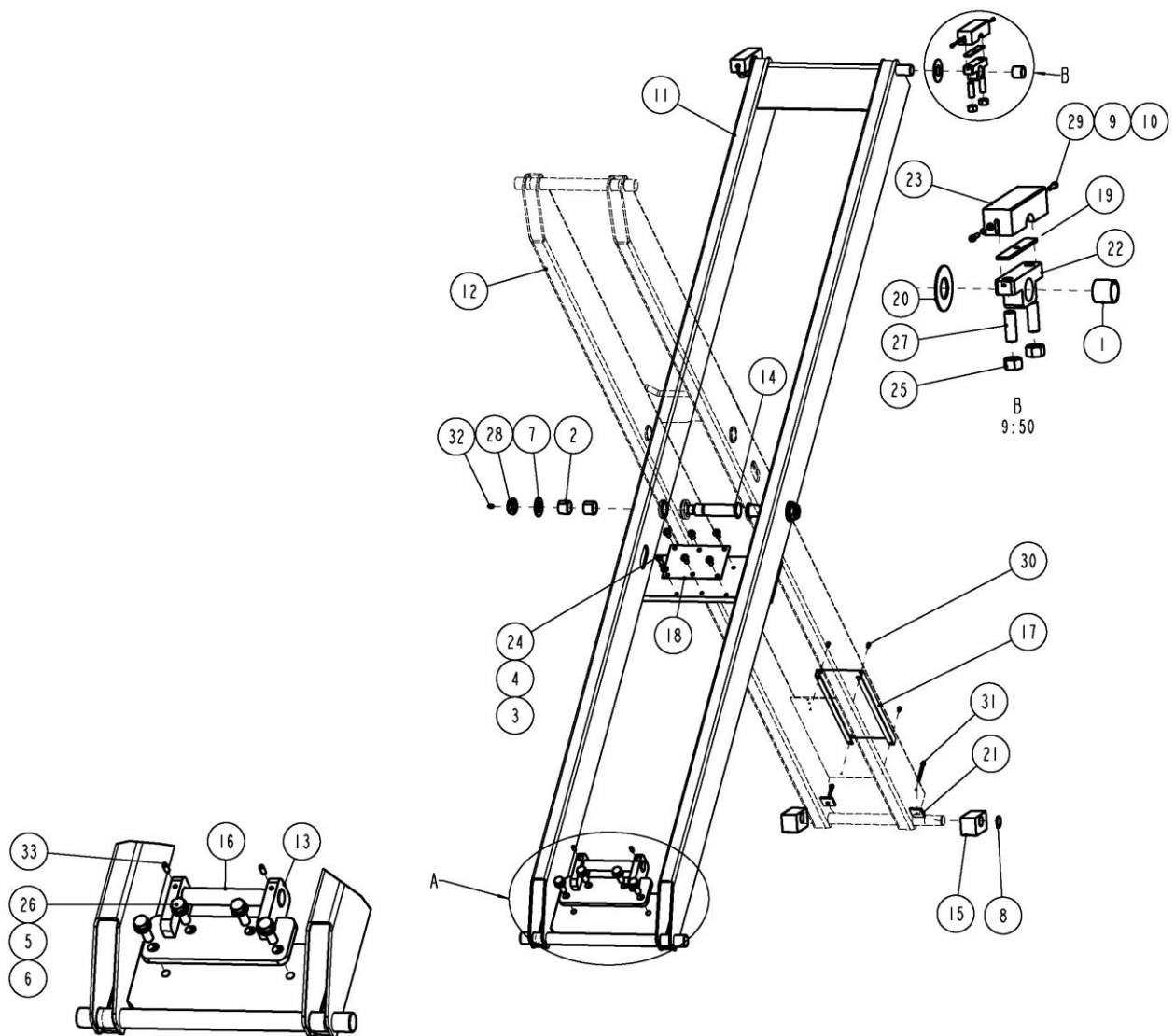

Pos.	Code	Component descriptions	Specification	Qty
1	205101020	Bearing	3030-SF-1X	2
2	205101109	Bearing	3530-SF-1X	4
3	204201005	Spring washer	D10-GB93	6
4	204101006	Flat washer C	D10-GB95	6
5	204201010	Spring washer	D16-GB93	4
6	204101009	Flat washer C	D16-GB95	4
7	204101015	Flat washer C	D30-GB95	2
8	204301011	Circle	D30-GB894_2	2
9	204201002	Spring washer	D5-GB93	4
10	204101003	Flat washer	D5-GB95	4
11	614901630	Outer arm	HX50-A2-B1	1
12	614901631	Inner arm	HX50-A2-B2	1

Pos.	Code	Component descriptions	Specification	Qty
13	614901632	Bottom cylinder holder	HX50-A2-B3	1
14	410911214	Central shaft of the arms	HX50-A2-B4	2
15	420680133	Lower sliding block	HX50-A2-B5	2
16	410911215	Lower cylinder shaft	HX50-A2-B7	1
17	410911216	Hose cover	HX50-A2-B9	1
18	410911206	Wheel padding plate	HX50-A2-B10	1
19	410911454	Adjustable padding plate	HX50-A2-B12	2
20	410911452	Large washer	HX50-A2-B13	2
21	410911716	Space plate	HX50-A2-B15	2
22	410911455B	Adjustable padding plate	HX50-A2-B11_1	2
23	420680134B	Upside siliding block	HX50-A2-B6_1	2
24	202110012	Hex socket button head screw	M10X25-GB70_2	6
25	203101009	Type I hex nut	M16-GB6170	4
26	201103007	Hex head full threaded bolt	M16X45-GB5783	4
27	202205002	Flat head locking screw	M16X50-GB77	4
28	203103016	Hex locking nut	M27X3-GB6172_1	2
29	202109011	Hex socket cylinder head screw	M5X20-GB70_1	4
30	202109007	Hex socket cylinder head screw	M5X8-GB70_1	4
31	202109026	Hex socket cylinder head screw	M6X60-GB70_1	2
32	208106001	Oil injection cup	M8X1-JB9740_1	2
33	202208010	Hex socket cylinder head locking screw	M8X20-GB79	2

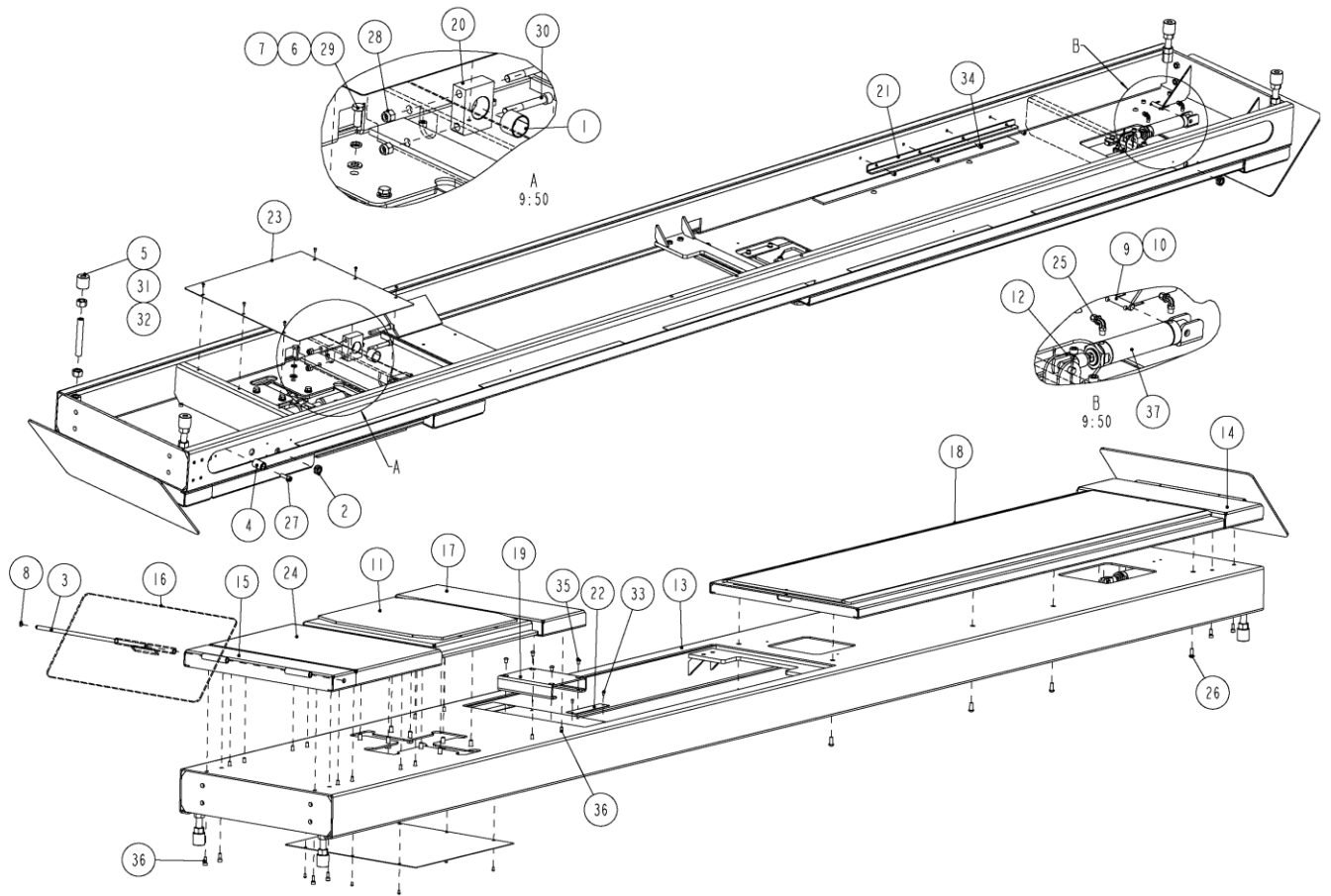
Platform A assembly

Pos.	Code	Component descriptions	Specification	Qty
1	205101109	Bearing	3530-SF-1X	2
2	420040020	Protective ring $\Phi 20$	6254E-A22	2
3	410250211	Shaft of the ramp	6604V2-A4-B12	2
4	420260040	Limit block	6605B-A21	1
5	420260010	Adjustable nylon block	6605B-A1-B8	4
6	204201006	Spring washer	D12-GB93	8
7	204101007	Flat washer	D12-GB95	8
8	204301002	Circle	D12-GB894_1	4
9	206103005	Pin with hole	D12X55-GB880	1
10	206201008	Cotter pin	D4X30-GB91	2
11	615068567	PD8 assembly	EE-PD8-50	1
12	310304002	Y connector	F-M12X125-Y	1
13	614901633	Platform A	HX50-A3-B1	1
14	614901635	Fixed box 205mm	HX50-A3-B2	1
15	614901636	Fix box 125mm	HX50-A3-B3	1
16	614901637	Small ramp	HX50-A3-B4	2

Pos.	Code	Component descriptions	Specification	Qty
17	614901638	Fix box 235mm	HX50-A3-B6	1
18	615068572	Slip plate assembly	HX50-A3-B7	1
19	410911291	Limit plate for the wheel-free lift	HX50-A3-B8	1
20	410911223	Upper support holder	HX50-A3-B9	2
21	410911383	Anti-overturning upper plate	HX50-A3-B10	2
22	410911218	Anti-wear plate	HX50-A3-B11	2
23	410911219	Covering plate for PD	HX50-A3-B12	1
24	614901634	Box 470mm	HX50-A3-B13	1
25	310102024	Quick elbow pneumatic connector	KLL8-01	2
26	202110012	Hex socket button head screw	M10X25-GB70_2	8
27	202109044	Hex socket cylinder head screw	M10X35-GB70_1	1
28	203103008	Hex locking nut	M12-GB889_1	4
29	201102027	Hex head full threaded bolt	M12X30-GB5783	8
30	202109155	Hex socket cylinder head screw	M12X90-GB70_1	4
31	203101012	Hex nut	M20-GB6170	8
32	202205005	Hex socket flat head locking screw	M20X140-GB77	4
33	202110003	Hex socket button head screw	M6X12-GB70_2	10
34	202109148	Hex socket cylinder head screw	M8X10-GB70_1	8
35	202110004	Hex socket button head screw	M8X12-GB70_2	4
36	202109029	Hex socket cylinder head screw	M8X20-GB70_1	20
37	310502001	Pneumatic cylinder	MA40X100SCA	1

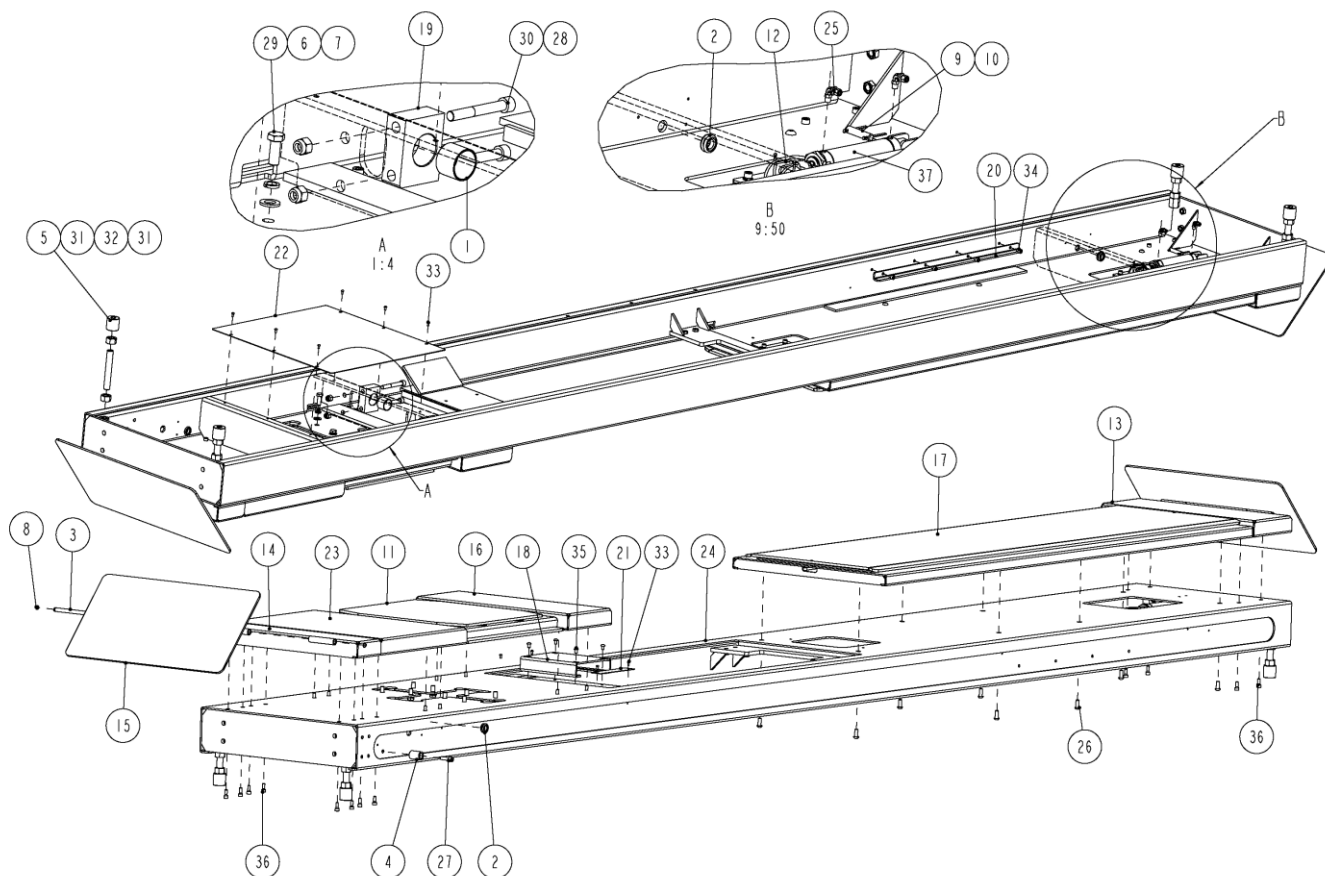
Platform B assembly

Pos.	Code	Component descriptions	Specification	Qty
1	205101109	Bearing	3530-SF-1X	2
2	420040020	Protective ring $\Phi 20$	6254E-A22	2
3	410250211	Shaft of the ramp	6604V2-A4-B12	2
4	420260040	Limit block	6605B-A21	1
5	420260010	Adjustable nylon block	6605B-A1-B8	4
6	204201006	Spring washer	D12-GB93	8
7	204101007	Flat washer	D12-GB95	8
8	204301002	Circle	D12-GB894_1	4
9	206103005	Pin with hole	D12X55-GB880	1
10	206201004	Cotter pin	D3X45-GB91	2
11	615068567	PD8 assembly	EE-PD8-50	1
12	310304002	Y connector	F-M12X125-Y	1
13	614901635	Fixed box 205mm	HX50-A3-B2	1
14	614901636	Fix box 125mm	HX50-A3-B3	1
15	614901637	Small ramp	HX50-A3-B4	2
16	614901638	Fix box 235mm	HX50-A3-B6	1
17	615068572	Slip plate assembly	HX50-A3-B7	1

Pos.	Code	Component descriptions	Specification	Qty
18	410911291	Limit plate for the wheel-free lift	HX50-A3-B8	1
19	410911223	Upper support holder	HX50-A3-B9	2
20	410911383	Anti-overturning upper plate	HX50-A3-B10	2
21	410911218	Anti-wear plate	HX50-A3-B11	2
22	410911219	Covering plate for PD	HX50-A3-B12	1
23	614901634	Box 470mm	HX50-A3-B13	1
24	614901639	Weld platform B	HX50-A3B-B1	1
25	310102024	Quick elbow pneumatic connector	KLL8-01	2
26	202110012	Hex socket button head screw	M10X25-GB70_2	8
27	202109044	Hex socket cylinder head screw	M10X35-GB70_1	1
28	203103008	Hex locking nut	M12-GB889_1	4
29	201102027	Hex head full threaded bolt	M12X30-GB5783	8
30	202109155	Hex socket cylinder head screw	M12X90-GB70_1	4
31	203101012	Hex nut	M20-GB6170	8
32	202205005	Hex socket flat head locking screw	M20X140-GB77	4
33	202110003	Hex socket button head screw	M6X12-GB70_2	10
34	202109148	Hex socket cylinder head screw	M8X10-GB70_1	8
35	202110004	Hex socket button head screw	M8X12-GB70_2	4
36	202109029	Hex socket cylinder head screw	M8X20-GB70_1	20
37	310502001	Pneumatic cylinder	MA40X100SCA	1

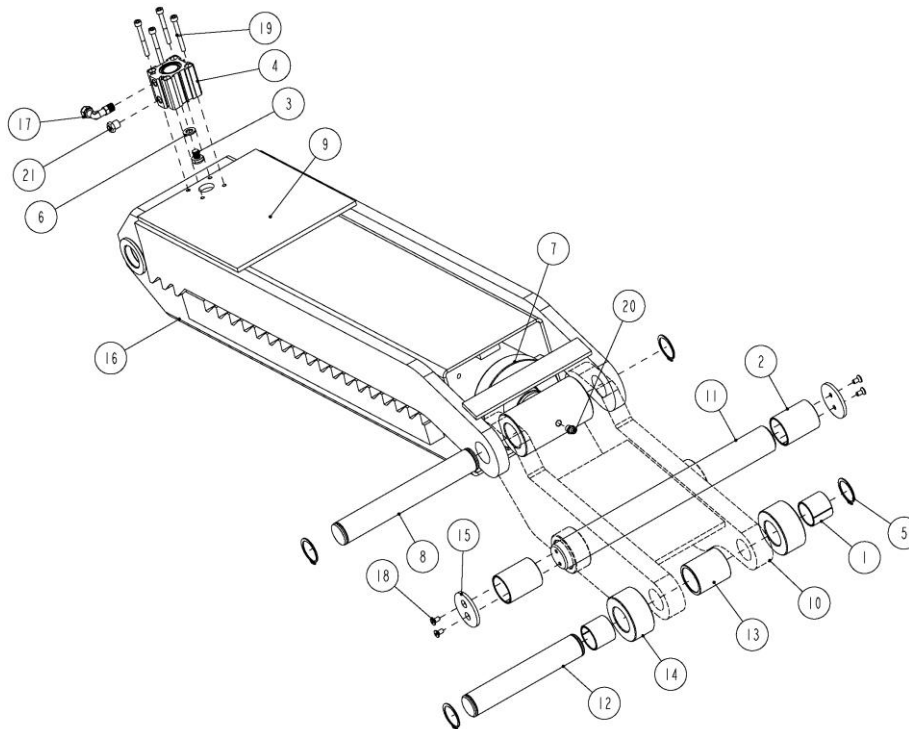
Slave cylinder and latch assembly for the wheel-support platform

Pos.	Code	Component descriptions	Specification	Qty
1	205101020	Bearing	3030-SF-1X	2
2	205101030	Bearing	3550-SF-2X	2
3	420420010	Adjustable head	66035-A03-B09	1
4	310501001	Pneumatic cylinder	CQ2B32X20-A	1
5	204301011	Circlip	D30-GB894_2	4
6	204101005	Flat washer	D8-GB95	1
7	410911226	Upper shaft of oil cylinder	HX50-A4-B2	1
8	614901641	Welded large side plate	HX50-A4-B3	1
9	614901642	Start plate	HX50-A4-B4	1
10	410911229	Central plate for the start plate	HX50-A4-B5	1
11	410911230	Shaft for rolling wheel	HX50-A4-B6	1
12	410911231	Spacer sheath for the start plate	HX50-A4-B7	1
13	410911232	Rolling wheel	HX50-A4-B8	2
14	410911380	Stop plate for shaft	HX50-A4-B9	2
15	614901643	Welded secondary safety ratchet	HX50-A4B-B1	1
16	310102024	Quick elbow pneumatic connector	KLL8-01	1
17	202111001	Hex socket flat head screw	M5X10-GB70_3	4
18	202109014	Hex socket cylinder head screw	M5X45-GB70_1	4
19	208106001	Straight grease injection cup	M8X1-JB9740_1	1
20	310201003	Silencer	SLM01-R1-8	1

Pos.	Code	Component descriptions	Specification	Qty
21	615068517	Slave cylinder for wheel-support platform	YG100-114-50-645	1

Master cylinder and latch assembly for the wheel-support platform

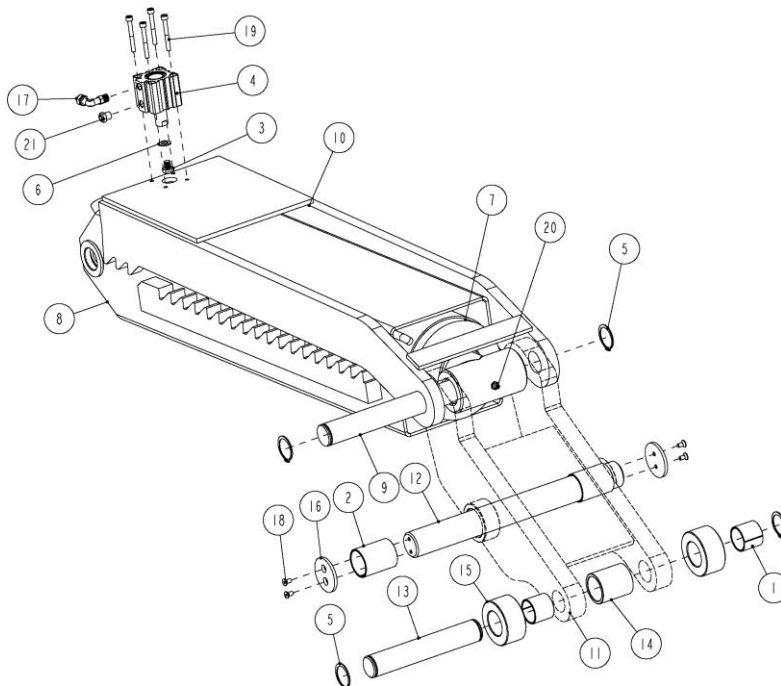

Pos.	Code	Component descriptions	Specification	Qty
1	205101020	Bushing	3030-SF-1X	2
2	205101030	Bushing	3550-SF-2X	2
3	420420010	Adjustable head	66035-A03-B09	1
4	310501001	Pneumatic cylinder	CQ2B32X20-A	1
5	204301011	Circlip	D30-GB894_2	4
6	204101005	Flat washer	D8-GB95	1
7	614901640	Mechanical lock assembly for the master platform	HX50-A4-B1	1
8	410911226	Upper cylinder shaft	HX50-A4-B2	1
9	614901641	Large side plate	HX50-A4-B3	1
10	614901642	Start rolling plate	HX50-A4-B4	1
11	410911229	Middle shaft of the start rolling plate	HX50-A4-B5	1
12	410911230	Shaft of the rolling wheel	HX50-A4-B6	1
13	410911231	Spacer sheath of the start rolling plate	HX50-A4-B7	1
14	410911232	Rolling wheel	HX50-A4-B8	2
15	410911380	Stop chip for the shaft	HX50-A4-B9	2
16	310102024	Quick elbow pneumatic connector	KLL8-01	1
17	202111001	Hex socket flat head screw	M5X10-GB70_3	4
18	202109014	Hex socket cylinder head screw	M5X45-GB70_1	4
19	208106001	Straight grease injection cup	M8X1-JB9740_1	1

20	310201003	Silencer	SLM01-R1-8	1
21	615068516	Master cylinder of the wheel-support platform	YG120-140-67-645	1

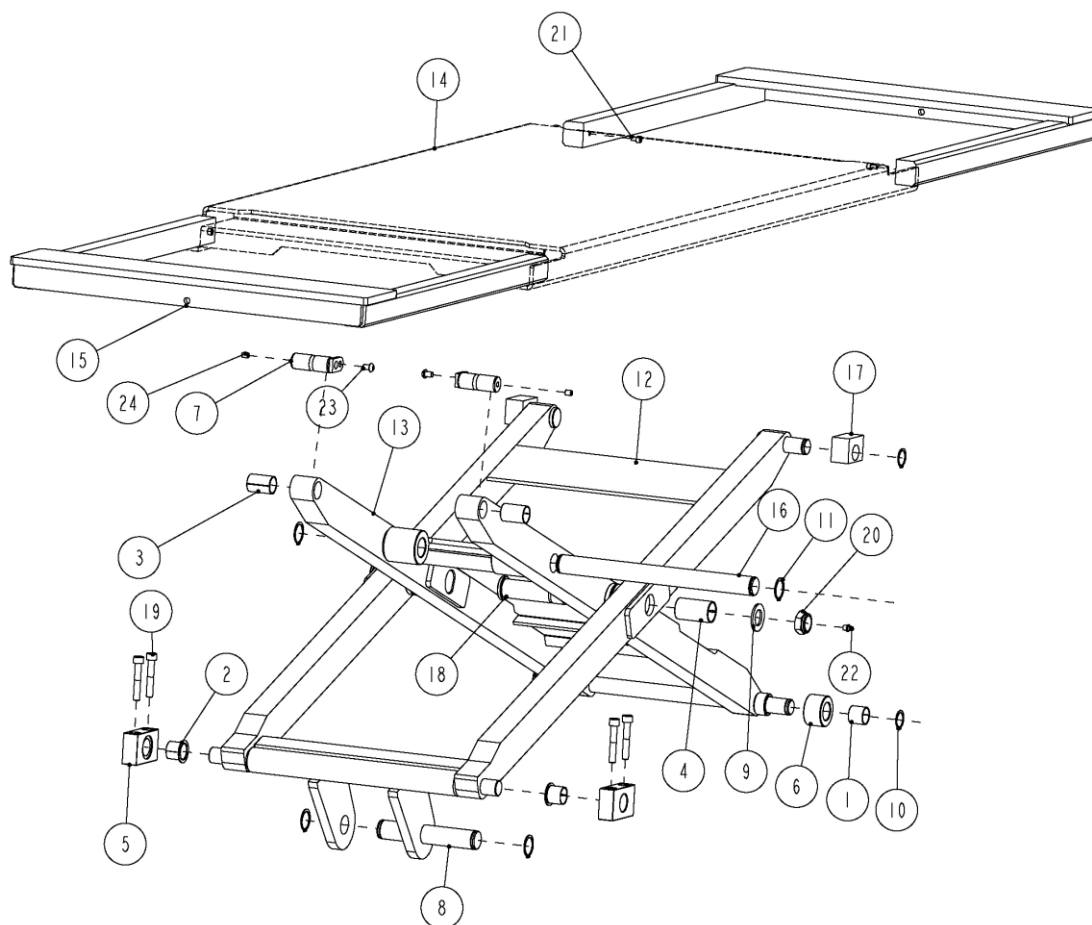
Wheel-free platform

Pos.	Code	Component descriptions	Specification	Qty
1	205101010	Bushing	2525-SF-1X	2
2	205103003	Flange bushing	2525F	2
3	205101094	Bushing	2540-SF-1X	2
4	205101024	Bushing	3055-SF-1X	2
5	410276701	Bottom holder	6435BWF-C03-20	2
6	410276711B	Rolling wheel	6435BWF-C03-21	2
7	612019504	Weld Revolving shaft assembly	65012-A1-B5	2
8	410254541	Lower cylinder shaft for the wheel-free lift	6604V2-A7-B7	1
9	204101012	Flat washer	D24-GB95	2
10	204301009	Circlip	D25-GB894_2	4
11	204301011	Circlip	D30-GB894_2	4
12	614901644	Outer support arm of the wheel-free lift	HX50-A5-B1	1
13	614901645	Inner support arm of the wheel-free lift	HX50-A5-B2	1
14	614901646	Platform of the wheel-free lift	HX50-A5-B3	1

Pos.	Code	Component descriptions	Specification	Qty
15	614901647	Platform extension	HX50-A5-B4	2
16	410911239	Upper cylinder shaft for the wheel-free lift	HX50-A5-B5	1
17	420680135	Upper sliding block for the wheel-free lift	HX50-A5-B6	2
18	410911240	Middle shaft of the support arm	HX50-A5-B7	2
19	202109153	Hex socket cylinder head screw	M10X60-GB70_1	4
20	203103018	Hex locking nut	M24X3-GB6172_2	2
21	202109018	Hex socket cylinder head screw	M6X10-GB70_1	4
22	208106001	Straight grease injection cup	M8X1-JB9740_1	2
23	202110004	Hex socket cylinder head screw	M8X12-GB70_2	2
24	208106002	Press-fit grease injection cup	M8YP-JB9740_4	2

Connection bar assembly

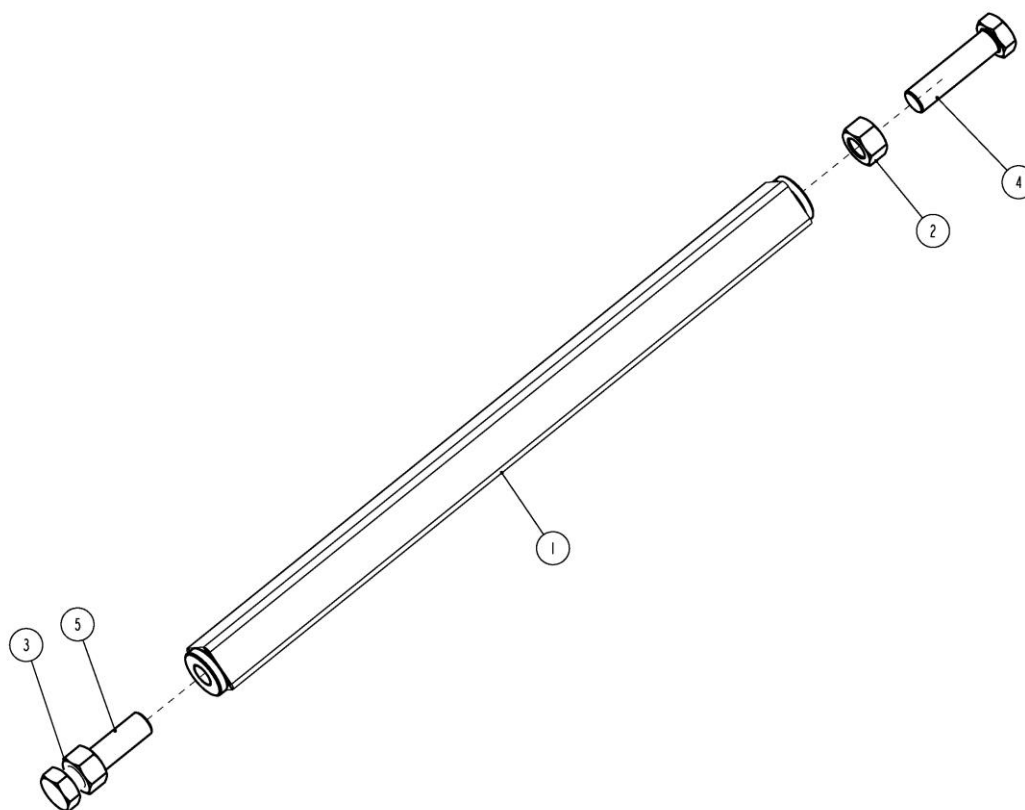

Pos.	Code	Component descriptions	Specification	Qty
1	614901682	Middle support rod	HX50-A9-B1	1
2	203101012	Hex nut	M20-GB6170	1
3	203101020	Hex nut (counter-clockwise screw)	M20-LH-GB6170	1
4	201101105	Hex head bolt	M20X80-GB5783	1
5	201101104	Hex head bolt (counter-clockwise screw)	M20X80-LH-GB5783	1

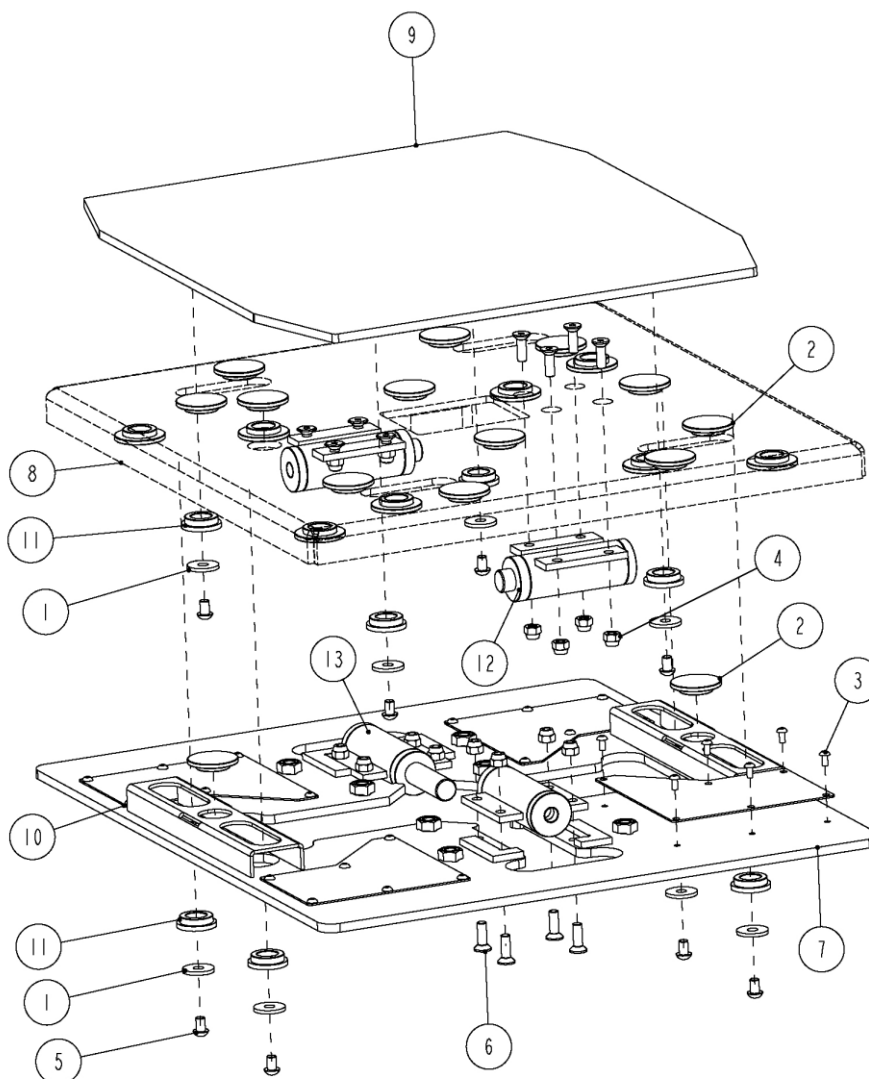

Pos.	Code	Component descriptions	Specification	Qty
1	204104203	Large washer	D8-GB5287	8
2	420310020C	Nylon pad	GEG-PD-A1-B5	22
3	202110001	Hex socket button head screw	M5X8-GB70_2	24
4	203103006	Locking nut	M8-GB889_1	16
5	202110004	Hex socket button head screw	M8X12-GB70_2	8
6	202111035	Hex socket flat head screw	M8X25-GB70_3	16
7	614901648	Base plate	PD8-50-A1-B1	1
8	614901649	Central box	PD8-50-A1-B2	1
9	612901650	Upper covering plate	PD8-50-A1-B3	1
10	410911244	Stainless steel pad plate	PD8-50-A1-B4	4
11	420680136	Nylon sheath	PD8-50-A1-B5	8
12	625000004	PD cylinder 1	YG30-40-20-53-59	2
13	625000018	PD cylinder 2	YG30-40-20-53-70	2

