

Model No.
EE-6435S/EE-6435B/EE-6435B.PD
Four Post Lift
Electrical Release

Installation, Operation
and Parts Manual

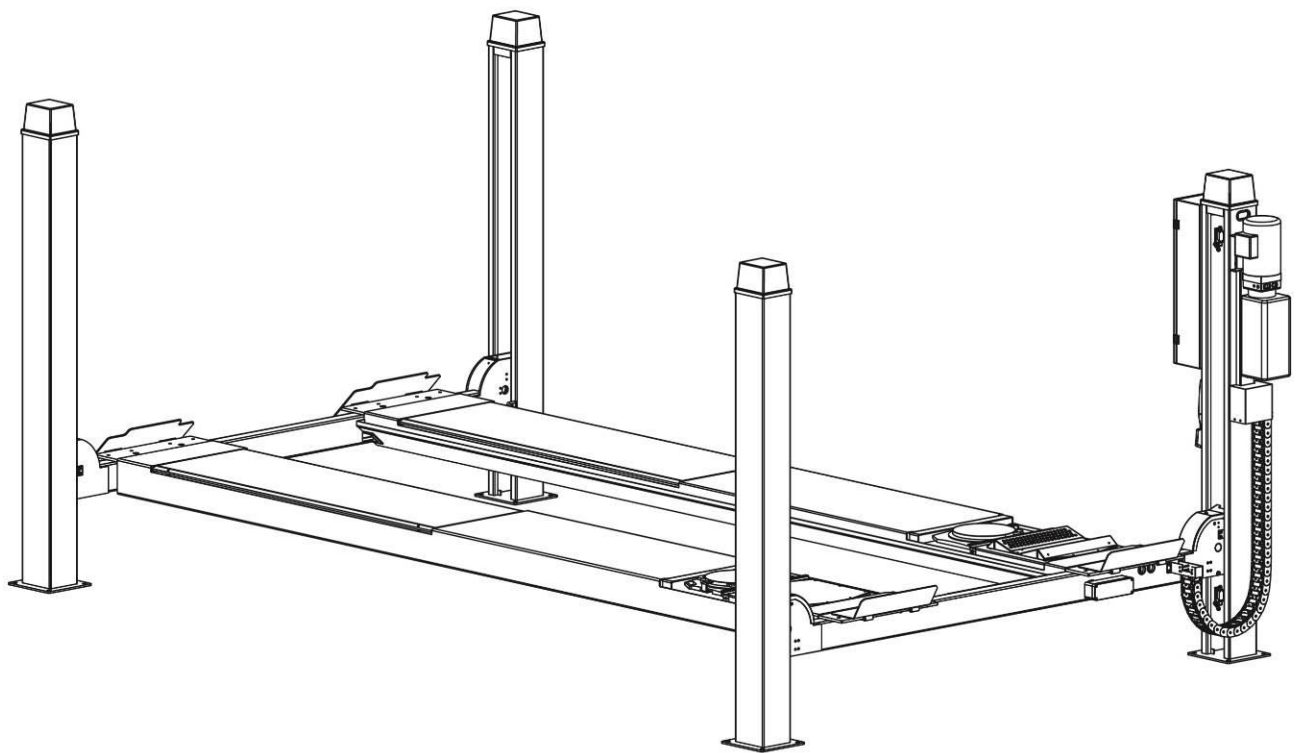

EAE



Distributed by

Please read this entire manual carefully and completely before installation or operation of the lift.

DATE: 31/10/2017

www.eae-ae.com

IMPORTANT NOTES

Before start up, connecting and operating EAE products, it is absolutely essential that the operating instructions/owner's manual and, in particular the safety instructions are studied carefully. By doing so you can eliminate any uncertainties in handling EAE products and thus associated safety risks up front; something which is in the interest of you own safety and will ultimately help avoid damage to the device.

When an EAE product is handed over to another person, not only the operating instructions but also the safety instructions and information on its designated use must be handed over to the person.

By using the product you agree the following conditions:

Copy right

The enclosed instructions are the property of EAE or its supplier, and are protected against duplication and reproduction by copyright laws, international agreements, and other domestic legislation. The reproduction or disclosure of instructions or an extract thereof is prohibited and offenders are liable to prosecution; EAE reserves the right or initiates criminal proceedings and asserts claims for damages in the event of infringements.

Warranty

The use of non-approved hardware will result in a modification of our products and thus to the exclusion of any liability or warranty, even if such hardware has been removed again in the interim.

It is not permissible to make any changes to our products and these are not only to be used together with genuine accessories and genuine replacement parts. Otherwise any warranty claims will be invalid.

Liability

The liability of EAE is limit to the amount that the customer has actually paid for this product. This exclusion of liability does not apply to damages caused through willful misconduct or gross negligence on the part of EAE.

All information in this manual is believed to be correct at time of publication.

EAE reserves the right to amend and alter technical data and composition without prior notice.

Please confirm at time of ordering.

IMPORTANT NOTES	2
SAFETY NOTES	4
1.1 Operation of lifting platforms	4
1.2 Checking of the lifting platforms	4
1.3 Important safety notices	5
1.4 Safety advices	6
1.5 Risks and safety instructions.....	7
1.6 Noise level	9
PACKING AND TRANSPORTATION	10
PRODUCTS DESCRIPTIONS	11
3.1 General descriptions.....	11
3.2 Mechanical safety construction.....	11
3.3 General construction of the lift	12
3.4 Technical data.....	12
3.5 Dimensions	13
3.6 Nameplate	15
INSTALLATION INSTRUCTIONS	16
4.1 Preparations before installation	16
4.2 Installation attentions.....	18
4.3 Installation instructions	18
4.4. Items to be checked after installation	25
OPERATION INSTRUCTIONS	25
5.1 Precautions	25
5.2 Descriptions of control panel.....	26
5.3 Flow chart for operation.....	29
5.4 Operation instructions.....	29
5.5 Emergency lowering in case of no power	31
TROUBLE SHOOTING	32
MAINTENANCE	33
Annex 1, Steel cable connection.....	34
Annex 2, Electrical schemes and parts list	35
Annex 3, Hydraulic schemes and parts list	46
Annex 4, Mechanical exploded drawings and parts list.....	53

SAFETY NOTES

1.1 Operation of lifting platforms

This lift is specially designed for lifting motor vehicles. Users are not allowed to use it for any other purposes. The applicable national regulations, laws and directives must be observed.

Only users aged 18 or above who have been instructed on how to operate the lifting platform and have proven their ability to do so to the owner are to be entrusted with unsupervised operation of lifting platforms. The task of operating the lifting platforms must be granted in writing.

Before loading a vehicle onto the lifting platform, users should study the original operation instructions and familiarize themselves with the operating procedures in several trial runs.

Lift vehicle within the rated load. Don't attempt to raise vehicles with excessive weight.

1.2 Checking of the lifting platforms

Checks are to be based on the following directives and regulations:

- Basic principles for testing lifting platforms
- The basic safety requirements stipulated in the directive 2006/42/EC
- The applicable accident prevention regulations

The checks are to be organized by the user of the lifting platform. The user is responsible for appointing an expert or qualified person to perform checking. It must be ensure that the person chosen satisfies the requirements.

The user bears special responsibility if employees of the company are appointed as experts or qualified persons.

1.2.1 Scope of checking

Regular checking essentially involves performing a visual inspection and a functional test. This includes checking the condition of the components and equipment, checking that the safety systems are complete and functioning properly and that the inspection log book is completely filled in. The scope of exceptional checking depends on the nature and extent of any structural modification or repair work.

1.2.2 Regular checking

After initial commissioning, lifting platforms are to be checked by a qualified person at intervals of no longer than one year.

A qualified person is somebody with the training and experience required to possess sufficient knowledge of lifting platforms and who is sufficiently familiar with the pertinent national regulations, accident prevention regulations and generally acknowledged rules of engineering to be able to assess the safe operating condition of lifting platforms.

1.2.3 Exceptional checking

Lifting platforms with a lift height of more than 2 meters and lifting platforms intended for use with people standing under the load bearing elements of the load are to be checked by an expert prior or reuse following structural modifications and major repairs to load bearing components.

An expert is somebody with the training and experience required to possess specialist knowledge of lifting platforms and who is sufficiently familiar with the pertinent national work safety regulations, accident prevention regulations and generally acknowledged rules of engineering to be able to check and give an expert opinion on lifting platforms.

1.3 Important safety notices

- 1.3.1 Recommend for indoor use only. DO not expose the lift to rain, snow or excessive moisture.
- 1.3.2 Only use this lift on a surface that is stable, level and dry and not slippery, and capable of sustaining the load. Do not install the lift on any asphalt surface.
- 1.3.3 Read and understand all safety warnings before operating the lift.
- 1.3.4 Do not leave the controls while the lift is still in motion.
- 1.3.5 Keep hands and feet away from any moving parts. Keep feet clear of the lift when lowering.
- 1.3.6 Only these properly trained personnel can operate the lift.
- 1.3.7 Do not wear unfit clothes such as large clothes with flounces, tires, etc., which could be caught by moving parts of the lift.
- 1.3.8 To prevent evitable incidents, surrounding areas of the lift must be tidy and with nothing unconcerned.
- 1.3.9 The lift is simply designed to lift the entire body of vehicles, with its maximum weight within the lifting capacity.
- 1.3.10 Always insure the safety locks are engaged before any attempt to work near or under the vehicle. Never remove safety related components from the lift. Do not use if safety related components are damaged or missing.
- 1.3.11 Do not rock the vehicle while on the lift or remove any heavy component from vehicle that may cause excessive weight shift.
- 1.3.12 Check at any time the parts of the lift to ensure the agility of moving parts and the performance of synchronization. Ensure regular maintenance and if anything abnormal occurs, stop using the lift immediately and contact our dealers for help.
- 1.3.13 Lower the lift to its lowest position and do remember to cut off the power source when service finishes.
- 1.3.14 Do not modify any parts of the lift without manufacturer's advice.
- 1.3.15 If the lift is going to be left unused for a long time, users are required to:
 - a. Disconnect the power;
 - b. Empty the oil tank;
 - c. Lubricate the moving parts with hydraulic oil.

WARNING: The warnings, cautions and instructions discussed in this instruction manual cannot cover all possible conditions and situations that may occur. It must be understood by the operator that common sense and caution are factors which cannot be built into this product, but must be supplied by the operator.

Attention: For environment protection, please dispose the disused oil in a proper way.

1.4 Safety advices

All safety warning labels are clearly depicted on the lift to ensure that the operator is aware of and avoid the dangers of using the lift in an incorrect manner. The labels must be kept clean and they have to be replaced if detached or damaged. Please read carefully the meaning of each label and memories them for future operation.

SAFETY ADVICE

540101451

	<p>Only trained personnel are allowed to operate the lift.</p>
	<p>Always keep lift area clear when lowering or raising vehicle.</p>
	<p>Do not try to raise a vehicle exceeds the rated capacity.</p>
	<p>Watch closely the vehicle during raising or lowering.</p>
	<p>It is not allowed to work under the vehicle if safety teeth are not engaged.</p>

	<p>It is not allowed to work under the vehicle if safety teeth are not engaged.</p>
	<p>Avoid excessive rocking of vehicle while on lift.</p>
	<p>Do not climb onto the lift platforms or raised vehicle during lifting or lowering.</p>
	<p>Do not change the safety mechanism.</p>
	<p>Carry out maintenance regularly as indicated in the manual.</p>

1.5 Risks and safety instructions

During lift functioning, the operator must remain in the control station as defined in figure 1.

The presence of persons beneath the cross-pieces and/or the platforms when they are moving, or the presence of persons inside the danger zone indicated in figure 2 is strictly prohibited. The area occupied from the lift and its surrounding width 1, 2 meters of the lift are defined as "DANGER ZONE".

The operator parking area, only for operating the lift, is defined as "OPERATEOR ZONE".

During operations persons are admitted to the area beneath the vehicle only when the vehicle is already in the elevated position, when the cross-pieces and platforms are stationary, and when the mechanical safety devices (wedges) are firmly engaged in the slots on the safety rods.

(Fig. 1)

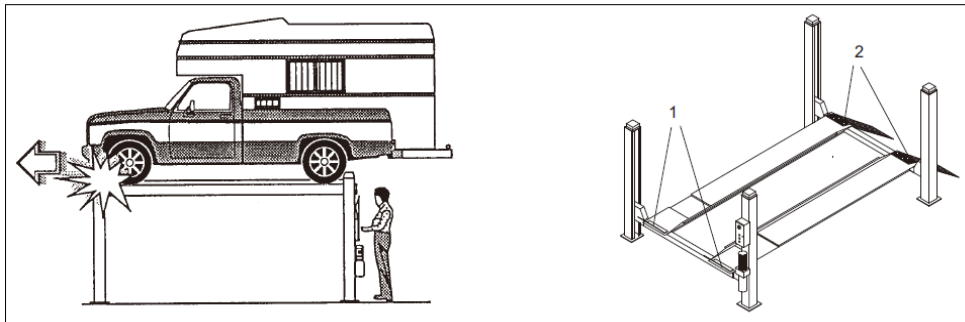

(Fig. 2)

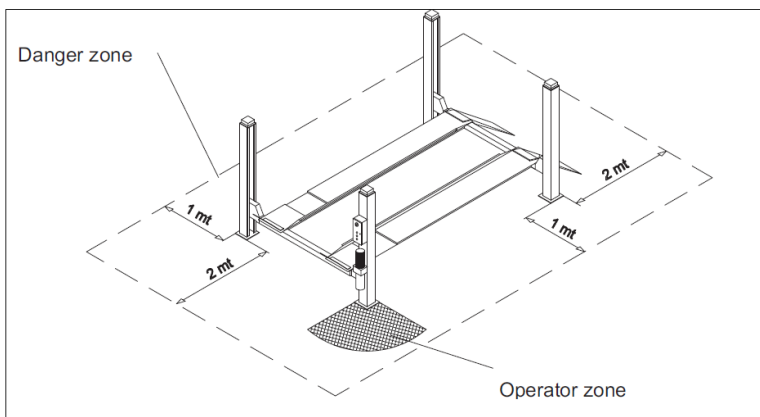

RISK OF CRUSHING (OPERATOR)

Possible if the operator controlling the lift is not in the specified position at the control panel.

When the platforms (and vehicle) are lowering the operator must never be partly or completely underneath or near of the movable structure.

Always remain in the operator zone (Fig. 3).

(Fig. 3) Operator zone

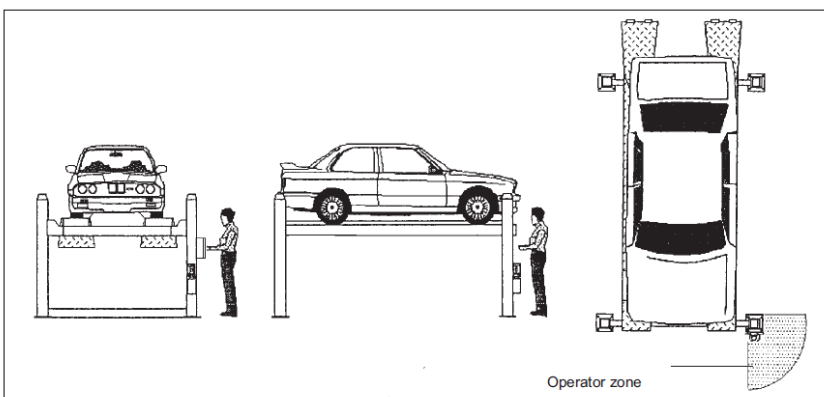

RISK OF CRUSHING (PERSONNEL)

When the platforms and the vehicle are lowering personnel are prohibited from entering the area beneath the movable parts of the lift (Fig.4). The lift operator must not start the lift until it has been clearly established that there are no persons in danger zone (Fig 1, 4, 5)

(Fig. 4)

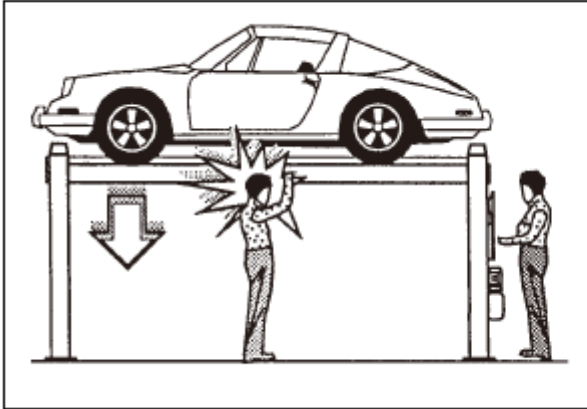

(Fig.5)

RISK OF IMPACT

Caused by the parts of the lift or the vehicle that are positioned at head height.

When, due to operational reasons, the lift is stopped at relatively low elevations (less than 1.75 m from the ground) personnel must be careful to avoid impact with parts of the machine not marked with special colors. (Fig.6)

RISK OF VEHICLE MOVING

Caused by operations involving the application of force sufficient to displace the vehicle.

In the case of large or particularly heavy vehicles, sudden movement could create an unacceptable overload or uneven load sharing. Therefore, before lifting the vehicle and during all operations on the vehicle

MAKE SURE THAT IT IS PROPERLY STOPPED BY THE HAND BRAKE.

(Fig.6)

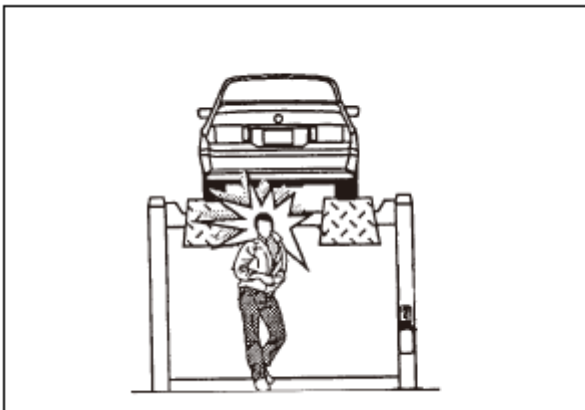

(Fig.7)

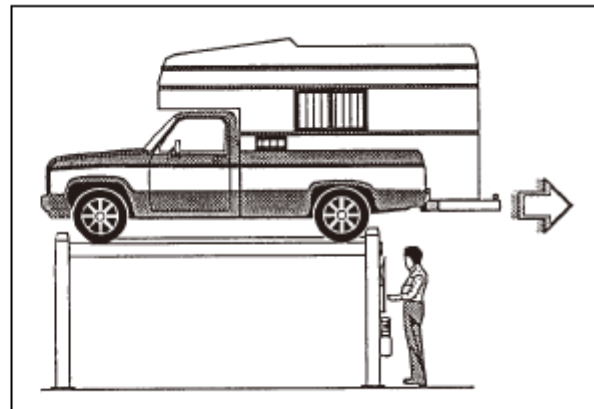

RISK OF VEHICLE FALLING FROM LIFT

This hazard may arise in the case of incorrect positioning of the vehicle on the platforms, incorrect stopping of the vehicle, or in the case of vehicles of dimensions that are not compatible with the capacity of the lift.

RISK OF SLACKENING OF LIFT CABLES

Caused by objects left leaning against the posts or on the platforms. (Fig. 9)

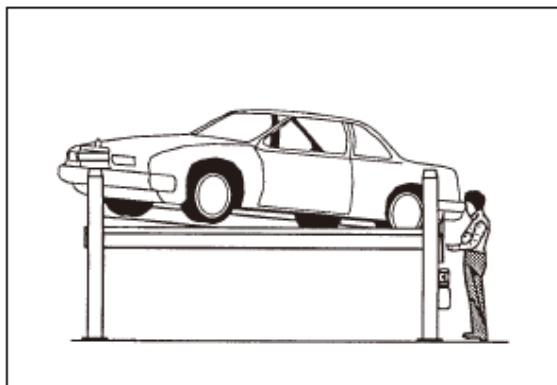
(Fig.8) risk of vehicle falling

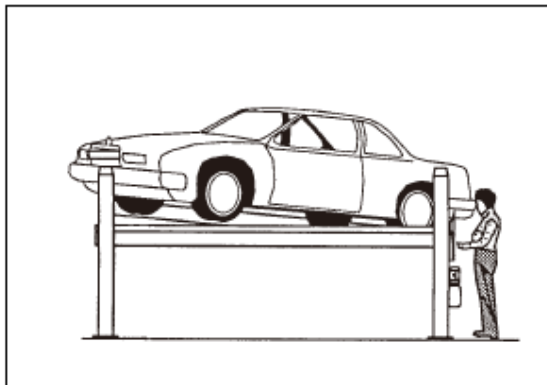

(Fig.9) risk of slackening of lift cables.

RISK OF SLIPPING

Caused by lubricant contamination of the floor around the lift (Fig. 10).

THE AREA BENEATH AND IMMEDIATELY SURROUNDING THE LIFT AND ALSO THE PLATFORMS MUST BE KEPT CLEAN. REMOVE ANY OIL SPILLS IMMEDIATELY.

RISKS RELATED TO IMPROPER USE

Persons are not permitted to stand or sit on the platforms during raising or lowering the lift or when the vehicle is already lifted. (Fig. 11)

(Fig. 10) Risk of slipping

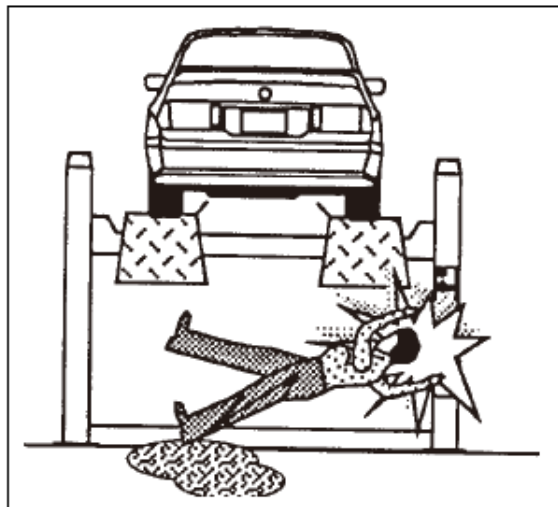

(Fig.11) Risks related to improper use

1.6 Noise level

Noise emitted during operating the lift should be less than 70dB. For your health consideration, it is suggested to place a noise detector in your working area.

PACKING AND TRANSPORTATION

Packing, lifting, handling, transporting operations must be performed only by experienced personnel with appropriate knowledge of the lift and after reading this manual.

Packing

The lift is shipped as a whole.

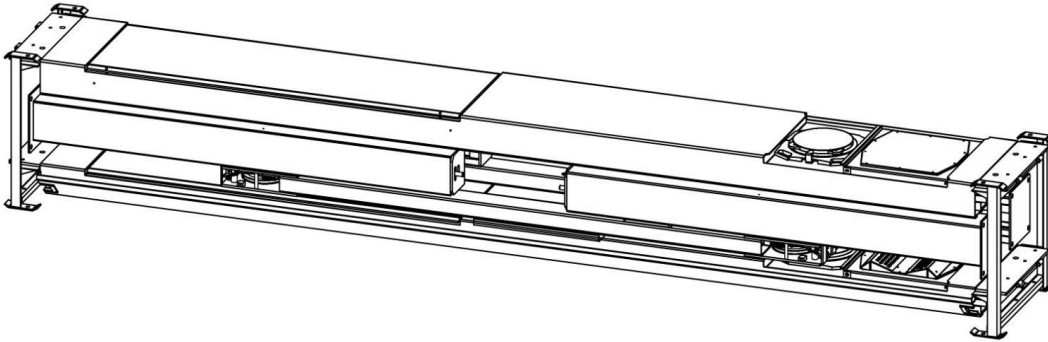

Lifting and handling

The packs can be lifted and transported only by using lift trucks. Never attempt to hoist or transport the unit using lifting slings.

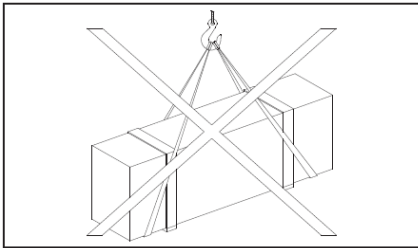

Storage

The packs must be kept in a covered and protected area in a temperature range of -10°C to $+40^{\circ}\text{C}$. They must not be exposed to direct sunlight.

Stacking the packs

We advise against stacking because the packs are not designed for this type of storage. The narrow base, heavy weight and large size of the packs make stacking difficult and potentially dangerous.

If stacking is unavoidable, use all appropriate precautions:

- never stack to more than 2 meters in height.
- never make stacks of single packs. Always stack pairs of packs in a cross pattern so that the base is bigger and the resulting stack is more stable. Once the stack is complete, restrain it using straps, ropes or other suitable methods.

A maximum of two packs can be stacked on lorries, in containers, and in railway wagons, on condition that the packs are strapped together and restrained to stop them falling.

Opening the packs

When the lift is delivered make sure that it has not been damaged during transportation and that all the parts specified on the packing list are present.

Packs must be opened adopting all the precautions required to avoid injury to persons (keep at a safe distance when cutting the straps) or damage to parts of the machine (be careful that no parts are dropped while you are opening the packing)

Take special care with the hydraulic power unit, the control panel and the platform cylinder.

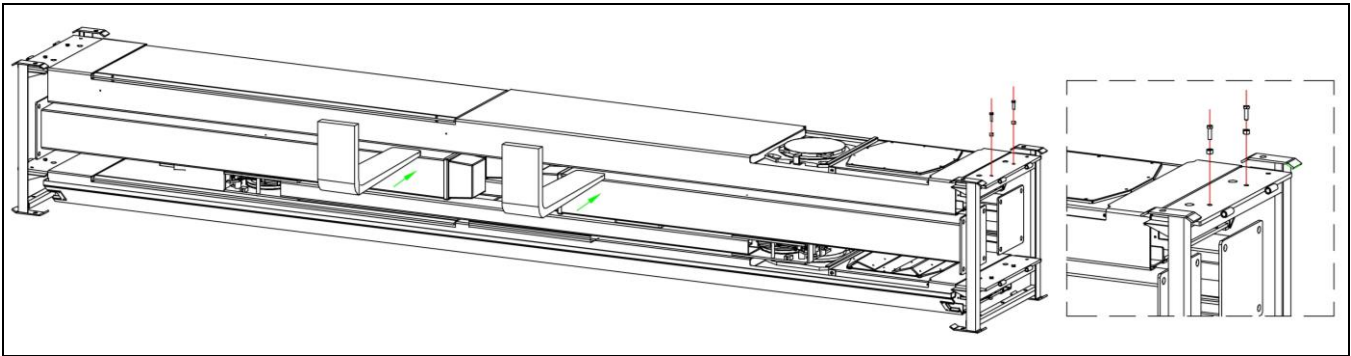

PRODUCTS DESCRIPTIONS

3.1 General descriptions

This four post lift is generally composed by four posts, two beams, two platforms, a hydraulic oil cylinder and a set of power unit. It is driven by an electro-hydraulic system. Up and down of platforms is controlled by the to and fro movement of the oil cylinder. It is equipped with mechanical safety locks in the four posts which automatically engage in the process of lifting so as to prevent the platforms from unexpected dropping down in case the hydraulic system fails to work.

3.2 Mechanical safety construction

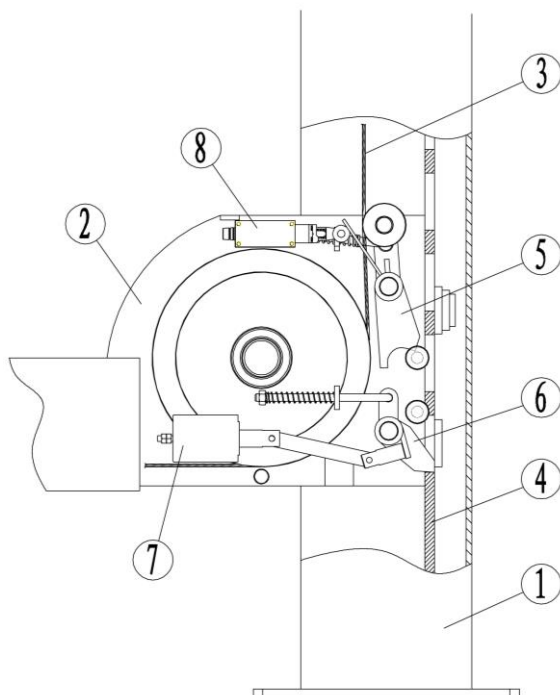

- 1 Post
- 2 Cross beam
- 3 Steel cable
- 4 Safety ladder
- 5 Safety block A
- 6 Safety block B
- 7 Electromagnet
- 8 Limit switch

3.3 General construction of the lift

MODEL S: Smooth and flat runway.

MODEL B: Runway with front recess for turntable and slip plate.

MODEL B.PD: Runway with front recess for turntable , slip plate play detector.

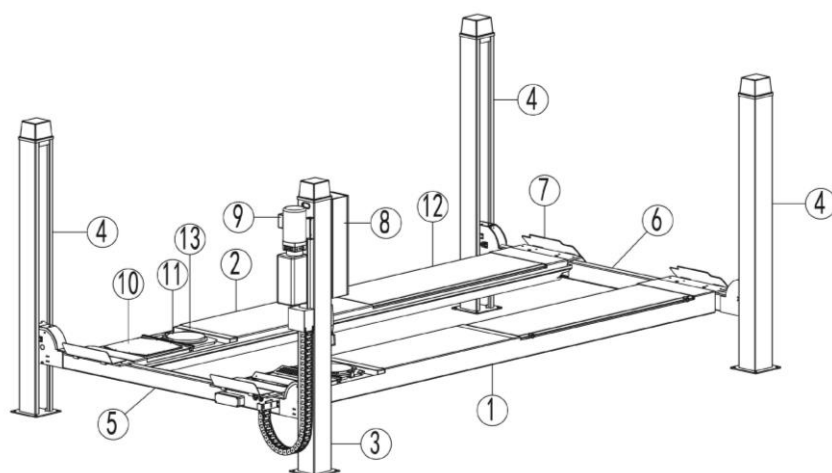

- 1 Power side platform
- 2 The opposite platform
- 3 Power side post
- 4 The opposite post
- 5 Power side cross beam
- 6 The opposite cross beam
- 7 Ramp assembly
- 8 Main control box
- 9 Power unit
- 10 PD assembly (optional)
- 11 Turn table
- 12 Side slip
- 13 Portable box

3.4 Technical data

Model	EE-6435S.52L.50T.E EE-6435B.52L.50T.E EE-6435B.52L.50T.E.PD	EE-6435S.48L.50T.E EE-6435B.48L.40T.E EE-6435B.48L.40T.E.PD
Power type	Electro-hydraulic	Electro-hydraulic
Rated capacity	5000kg	4000kg
Full rise height	1830mm	1830mm
Initial height	190mm	190mm
Full rise time	≤40S	≤40S
Full lowering time	≤50S	≤50S
Weight	1880kg	1830kg
Electrical requirements	AC 400V, 50Hz	
Motor capacity	2.2kW or 3.0kw	
Hydraulic oil	12L	

3.5 Dimensions

3.5.1 Dimension for EE-6435B.52L.50T.E.PD / EE-6435B.48L.40T.E.PD with long drive-on ramps (on-ground installation)

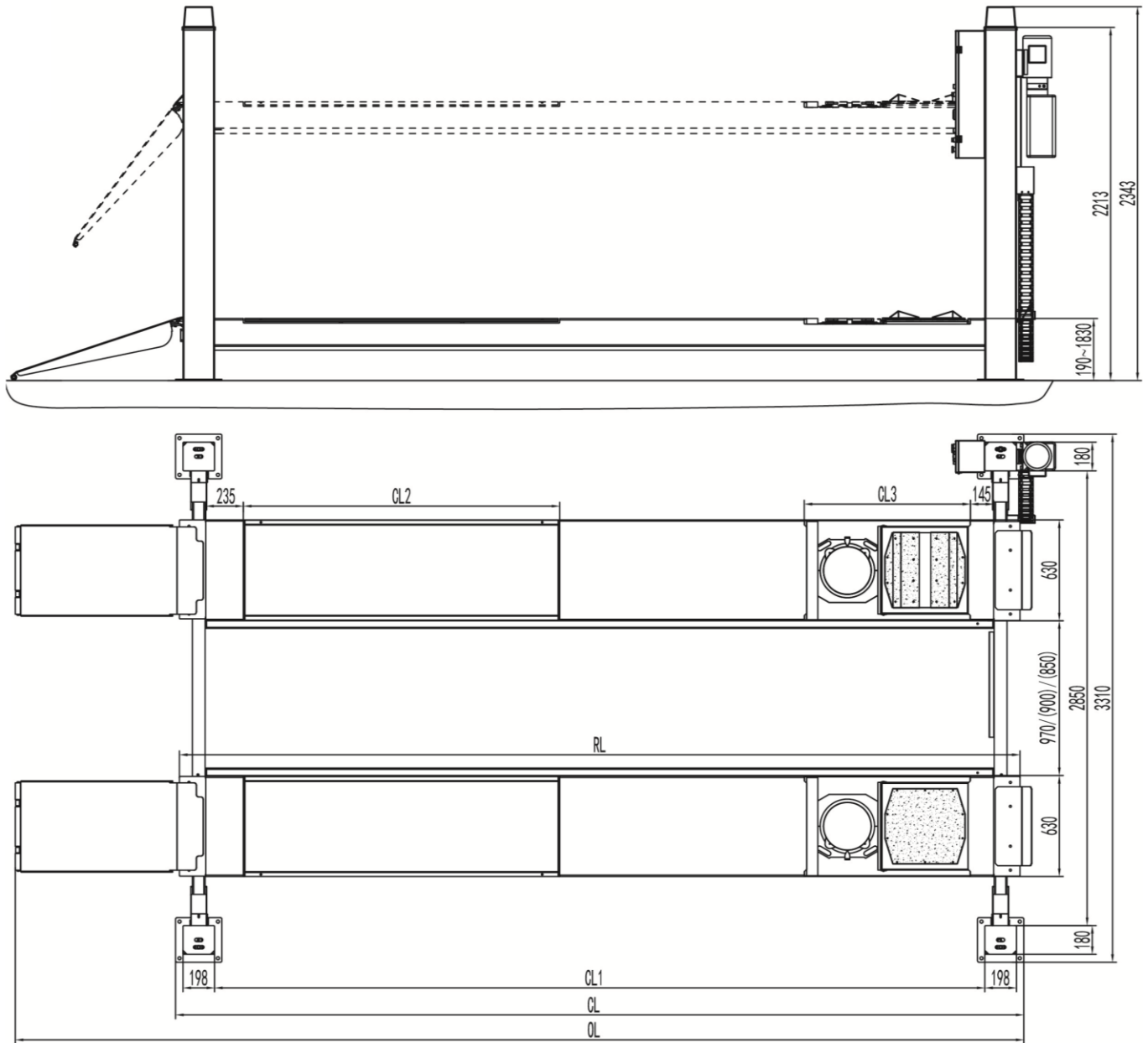

Model	EE-6435B.52L.50T.E.PD	EE-6435B.48L.40T.E.PD
RL	5280	4880
OL	6350	5950
CL	5308	5808
CL1	4820	4420
CL2	1980	1580
CL3	1040	970

3.5.2 Dimension for EE-6435B.52L.50T.E/ EE-6435B.48L.40T.E with long drive-on ramps (on-ground installation)

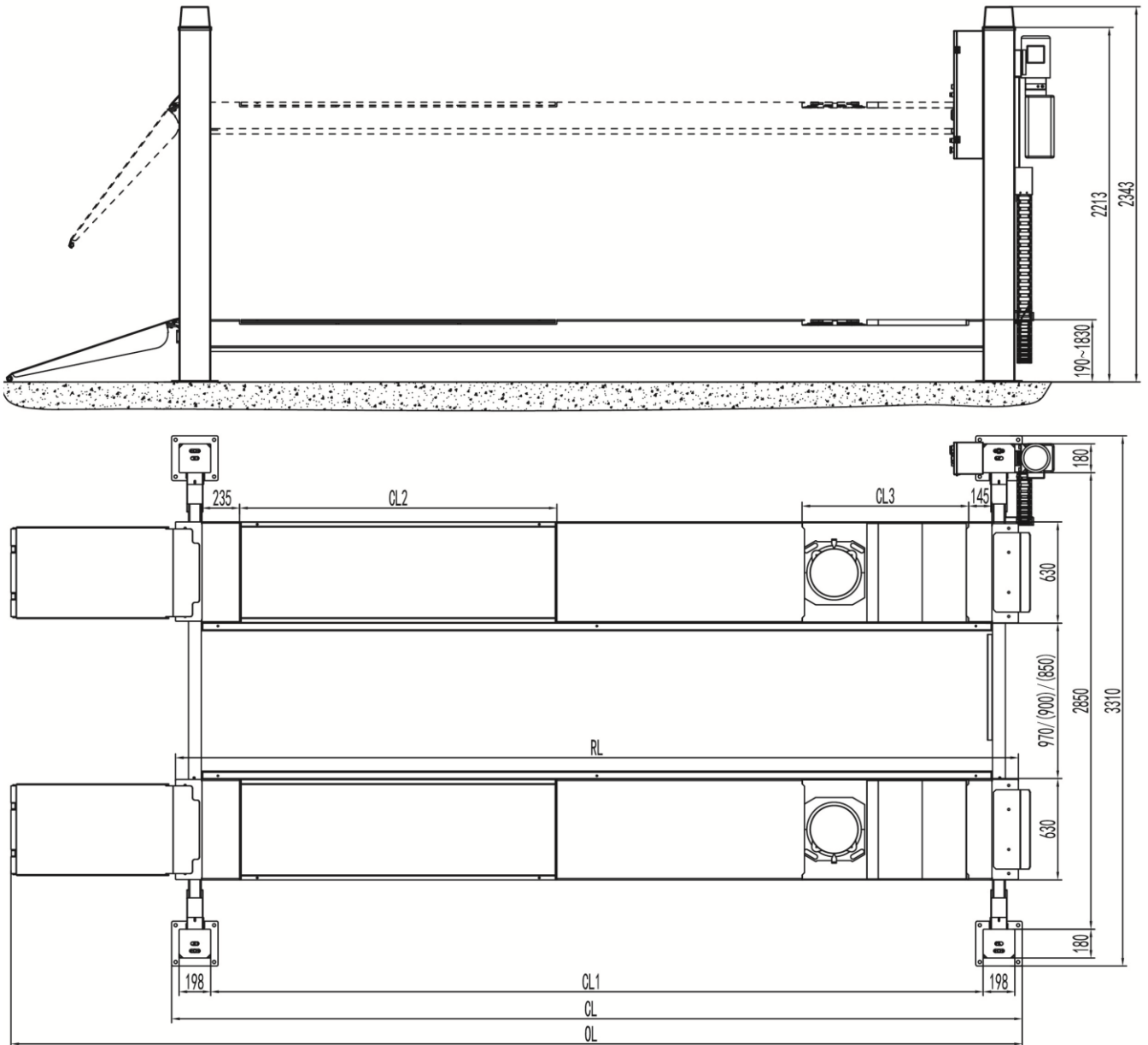

Model	EE-6435B.52L.50T.E	EE-6435B.48L.40T.E
RL	5280	4880
OL	6350	5950
CL	5308	5808
CL1	4820	4420
CL2	1980	1580
CL3	1040	970

3.5.3 Dimension for EE-6435S.52L.50T.E/ EE-6435S.48L.40T.E with long drive-on ramps (on-ground installation)

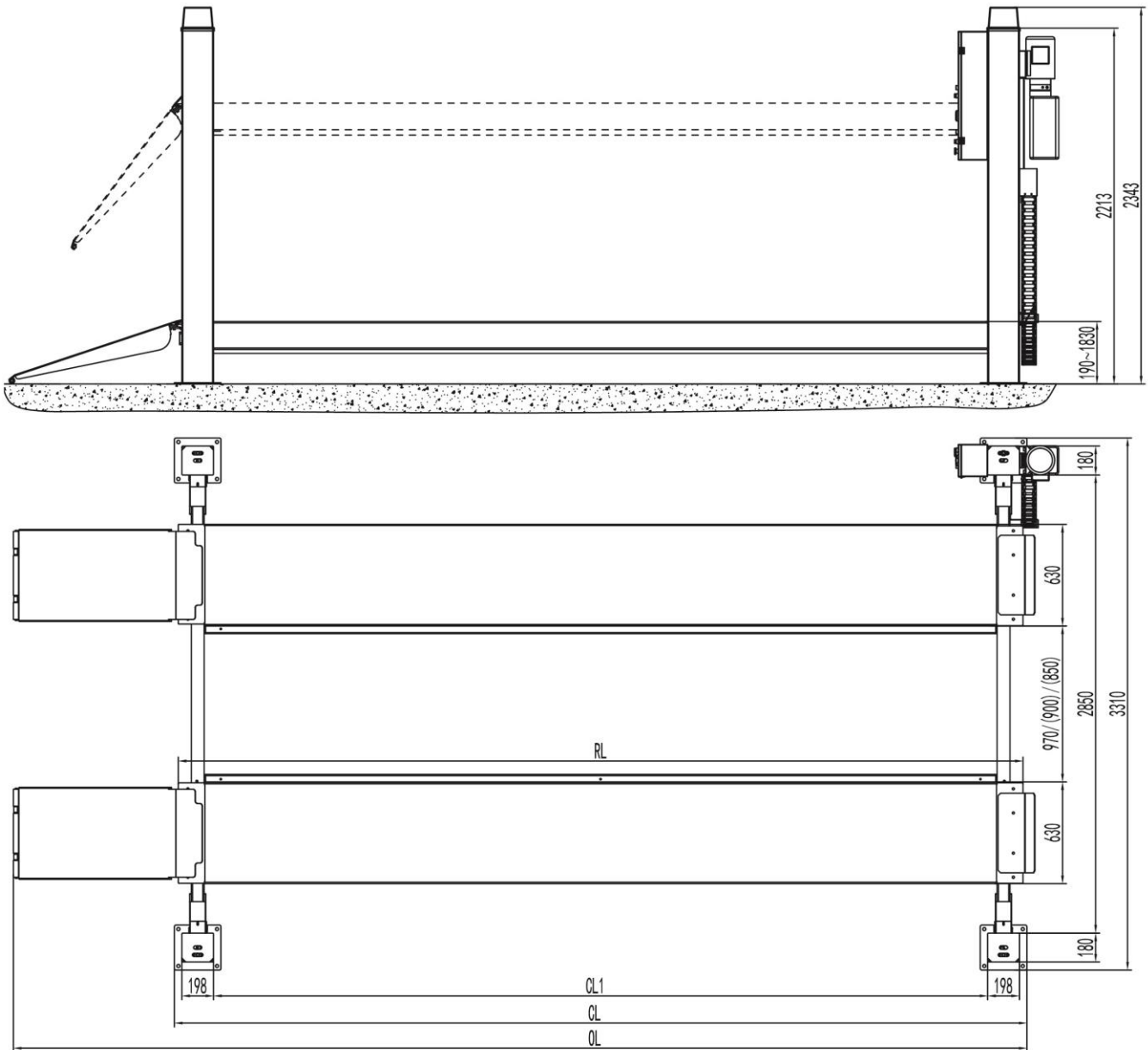

Model	EE-6435S.52L.50T.E	EE-6435S.48L.40T.E
RL	5280	4880
OL	6350	5950
CL	5308	5808
CL1	4820	4420

3.6 Nameplate

The nameplate is fixed beneath the oil tank

Check the work voltage and the lift capacity printed on the name plate.

Do not lift vehicles with weight beyond the capacity.

S/N and production date could be helpful for future service.

INSTALLATION INSTRUCTIONS

4.1 Preparations before installation

4.1.1 Space requirements.

Refer to 3.5 for the dimensions of the lift. There must also be a clearance of at least 1 meter between the lifting platform and fixed elements (e.g. wall) in all lifting positions. There must be sufficient space at the ends of the lifting platform for driving vehicles on and off. If not specifically stated, this lift is only for indoor use. Make sure that the space around or over the lift should be free of obstructions like heaters, building supports, electrical lines etc.

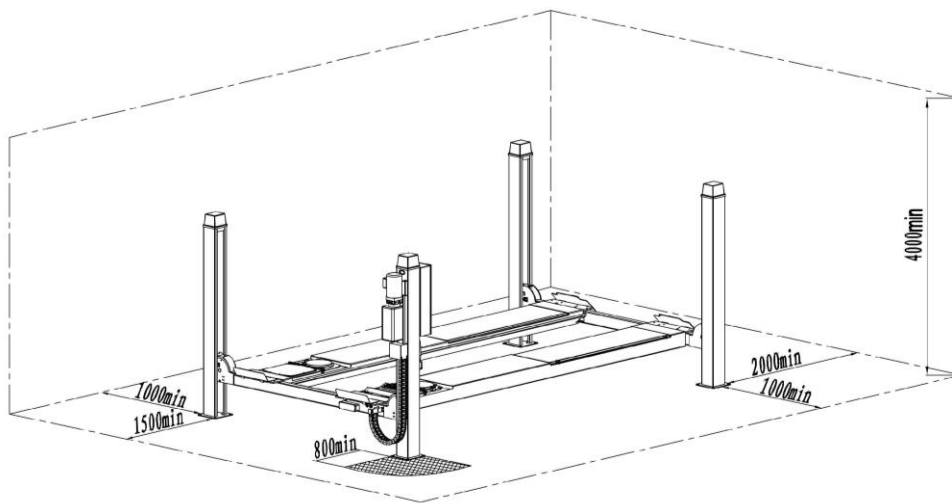

To stop vehicles colliding with the ceiling, it is advisable to fit an overhead light barrier in low ceiling buildings.

4.1.2 Foundations and connections

The user must have the following work performed before erecting the lift.

- Construction of the foundation following consultation with the manufacturer's customer service or an authorized service agent.
- Routing of the wiring to the installation location. The user must provide fuse protection for the connection.

4.1.3 Foundations preparations

Indoor installation only. There must also be a clearance of at least 1 meter between the lifting platform and fixed elements (e.g. wall) in all lifting positions. There must be sufficient space for driving vehicles on and off.

C20/25 concrete base with strength more than 3000psi, Minimum thickness of 200mm.

Surface: Horizontal and even (Gradients max. 0.5 %)

Newly built concrete ground must be older than 20days.

In mm.

4.1.4 Tools and equipment needed for installation

Tool name	Specification	Quantity
Electrical drill	With D16 and D18 drill bit.	1
Open spanner	D17-19mm	2
Hex socket spanner	D3,D4,D5mm	1
Adjustable spanner	small than D30mm	1
Cross socket screw driver	PH2	1
Levelling device		1
Hammer	10 pounds	1
Truck lift	Capacity more than 2500kg	1

4.1.5 Checking parts

Unfold the package and check if any parts missed as per the following list. Do not hesitate to contact us in case any parts missed, but if you do not contact us and insist installing upon the lack of some parts, we as well as our dealers will not bear any responsibility for this and will charge for any parts subsequently demanded by the buyer.

S/N	Name	Qty	Note
1	Power side post	1	Including relevant parts like ,steel cables, safety ladder, etc.
2	Post	3	Including relevant parts like ,steel cables, safety ladder, etc.
3	Power side crossbeam	1	Including relevant parts like ,steel cables, limit switch ,etc.
4	The secondary crossbeam	1	Including relevant parts like ,steel cables, limit switch ,etc.
5	Power side platform	1	Including relevant parts like ,steel cables, cylinder ,etc.
6	The secondary platform	1	Including relevant parts like ,steel cables ,etc.
7	Power unit	1	Including relevant parts like motor, gear pump, hydraulic block
8	Control box	1	Including relevant part like tank chain, tank chain holder A, tank chain holder B, M6*60 and M6*19 hex socket cylinder head screw and hex nut.
9	Ramp B	2	
10	Front wheel retainer	2	
11	Shaft	2	
12	Post cap	4	
13	Slider and slider holder	8	
14	Protection cover	4	
15	Oil hose slot	1	
16	PD charger holder	1	
17	PD charger with torch	1	
18	M8*12 hex socket button head screw	20	
19	Φ8 class C flat washer	20	
20	M12*25 Hex socket flat head screw	8	
21	φ2.5x30 cotter pin	4	

S/N	Name	Qty	Note
22	M10*35 hex head full swivel screw	8	
23	M10 hex nut	8	
24	Φ10 class C flat washer	8	
25	φ10 spring washer	4	
26	anti-vibration pad	4	
27	Expansion bolt M16*120	16	
28	Manual	1	

4.2 Installation attentions

4.2.1 Joints of oil hose and wiring must be firmly connected in order to avoid leakage of oil hose and looseness of electrical wires.

4.2.2 All bolts should be firmly screwed up.

4.2.3 Do not place any vehicle on the lift in the case of trial running.

4.3 Installation instructions

Step 1: Fix the installation layout.

Once the installation site is determined, mark first the four standing points of the four posts by a tape measure and chalk. Ensure two diagonal lines are of the same length.

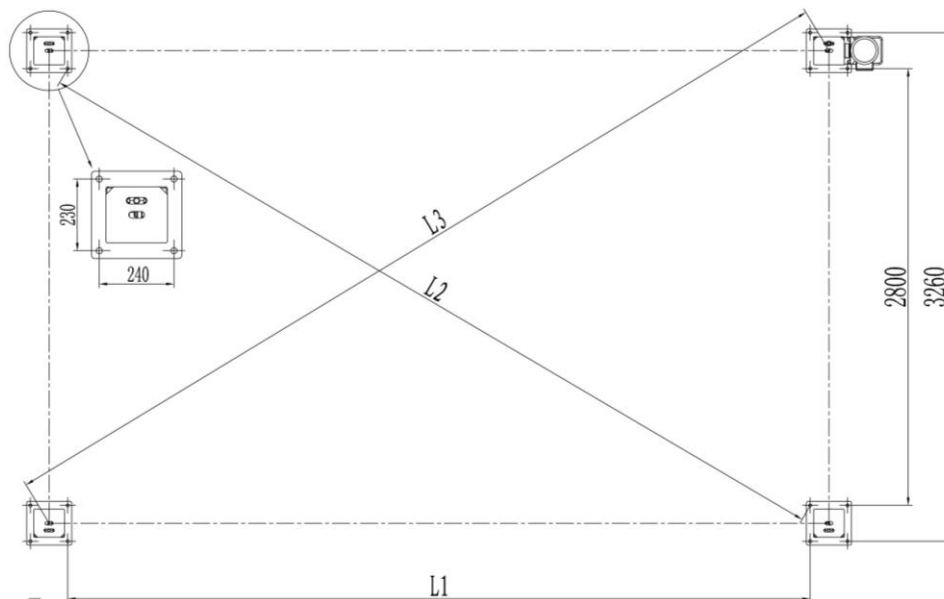

Dimension	52L runway	48L runway
L1	4778±2mm	4378±2mm
L2	5538±2mm	5196±2mm
L3	5862±2mm	5523±2mm

Step 2: Remove the packing materials.

1. Place some wooden battens (thickness of which should be more than 80mm) on the ground (other dependable devices may also applicable) and then use forklift to have the packing rack removed on to the battens so as to make its base is of some clearance from the ground.
2. Have the platforms of the lift suspended by the forklift and then screw off the upside bolt and remove the first platform on to the wooden battens initially prepared.
3. Screw off the downside bolt and take away the packing racks on both sides.
4. Remove the shock absorption plastic film with a knife.

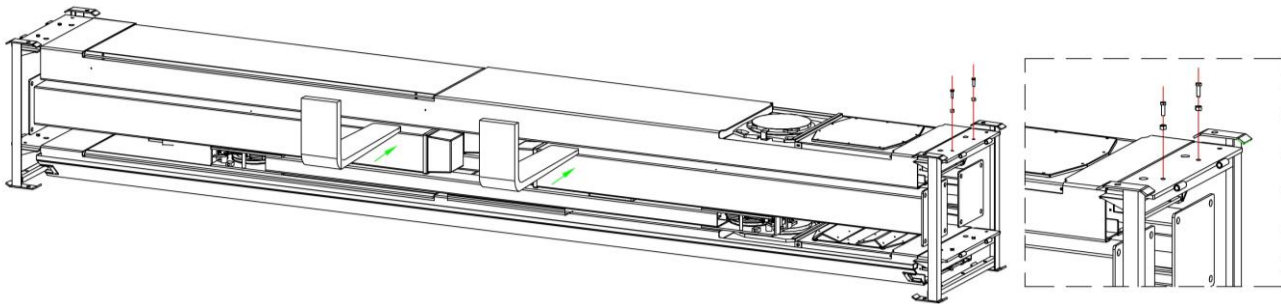
Step 3: Use the forklift to have the general parts positioned in accordance with following layout.

For convenient installation, it would be better to pad something supporting under the platform.

Oil cylinder, steel cable and oil hose have already been fixed in the power side platform (platform with oil cylinder beneath) before packing.

Pulleys and safety lock etc have already been fixed in the beams before packing.

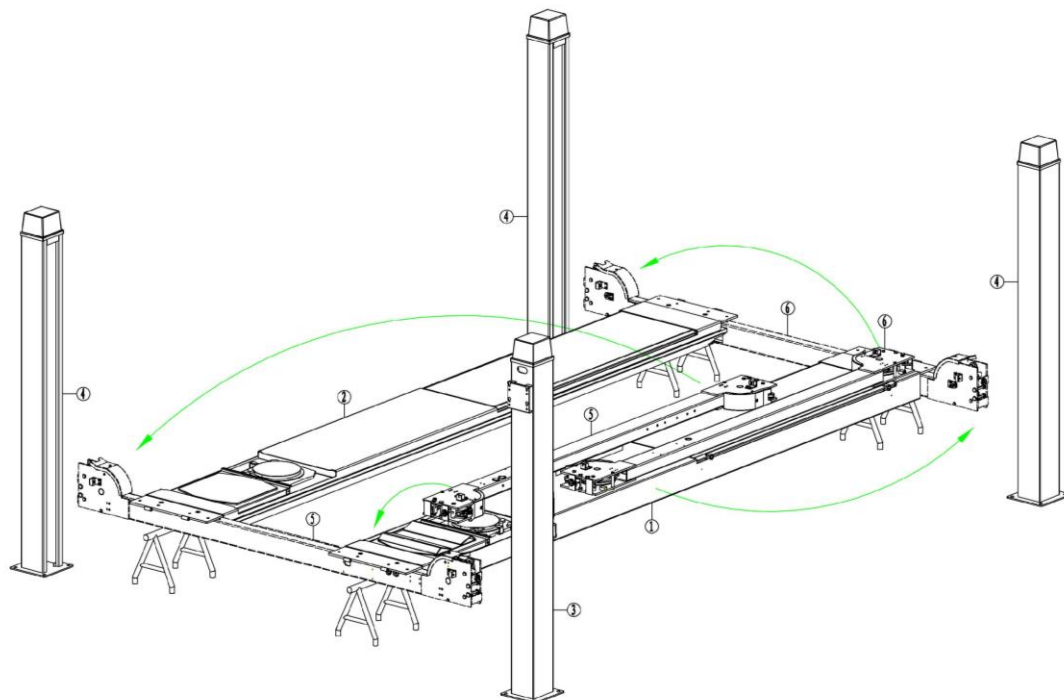

- 1 *Power side platform*
- 2 *The opposite platform*
- 3 *Power side post*
- 4 *The opposite post*
- 5 *Power side crossbeam*
- 6 *The opposite crossbeam*

Step 4: Connect the platforms and beams

Firstly, connect the main beam (the beam which connects to the power side post) with two platforms. Align accurately the screw sockets on the platform and the beam and fasten them (Installers can adjust the distance between two platforms on basis of practical needs.) (Meanwhile, pull out oil hose and air hose from the power side platform and make them go through the $\varnothing 40$ hole reserved on the cross beam. The two hoses will be finally connected to power unit) Fix the wheel retainers on to the platforms. Connect the other beam in the same way.

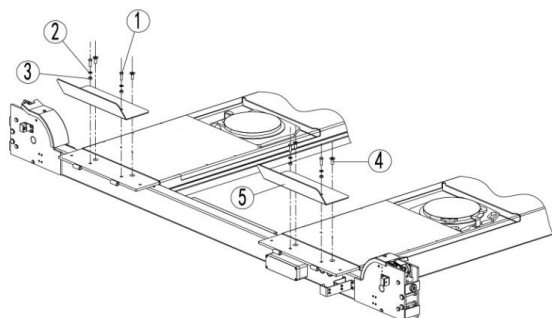

- 1 M10*35 hex head screw
- 2 $\varnothing 10$ flat washer
- 3 M10 Nut
- 4 M12*25 hex socket flat head screw
- 5 Wheel retainer

Step 5: Connect posts and cross beams

1. Pull up the safety ladder from the post with its bottom end higher than the height of cross beam.

Pull the post to the cross beam as the direction arrow showed in the following drawing

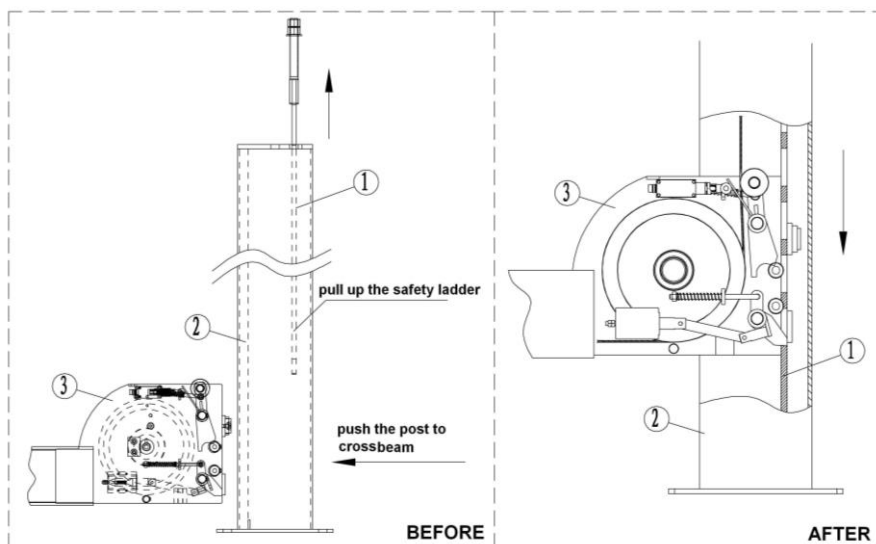

- 1 Safety ladder
- 2 Post
- 3 Cross beam

2. Fasten the top end of safety ladders to the top plate of each post.

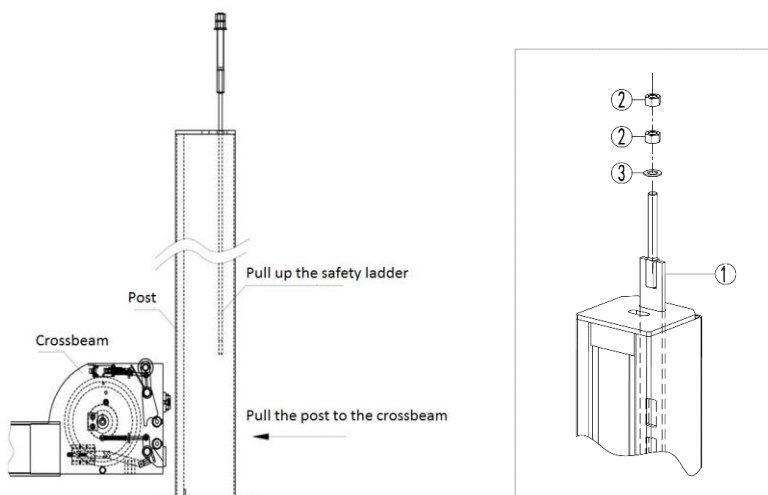

- 1 Safety ladder
- 2 M20 hex nut
- 3 $\varnothing 20$ flat washer

3. Pull out the steel cables from both ends of the cross beam and fasten them on the top plate of post (please see the Annex for the steel cable connection)

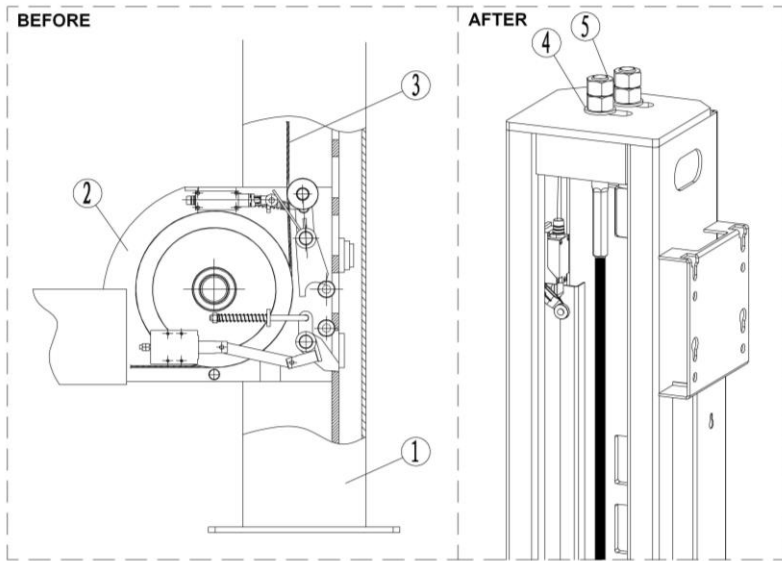

- 1 Post
- 2 Cross beam
- 3 Steel cable
- 4 M20 hex nut
- 5 φ20 flat washer

Step 6: Fit on 8 nylon sliders and 4 protection covers

1. Fasten the slider to its holder and then connect the slider holder and the cross beam.
2. Fix protection covers.

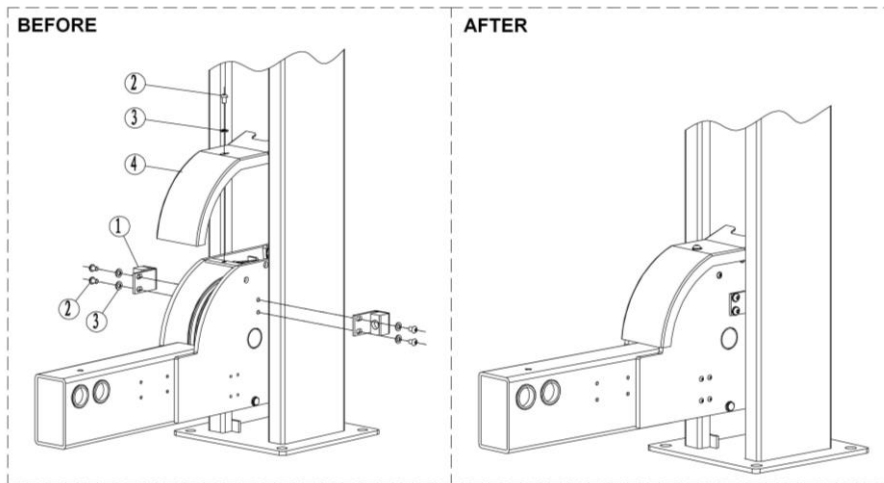

- 1 Slider holder
- 2 M8*12 hex socket button head screw
- 3 Flat washer φ8
- 4 Protection cover

Step 7: Fix the ramps.

Align the end of the platform and the hole on the ramp and connect them with shaft and cotter pins.

Align the ramp and the shaft sheath at the end of the platform and connect them with shaft and cotter pins.

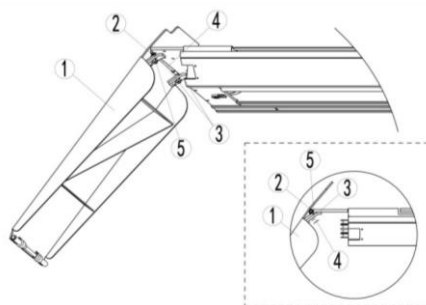

- 1 Drive-on ramp A
- 2 Shaft sheath
- 3 Adjustable plate
- 4 Shaft
- 5 Cotter pin

Step 8: Fit on four post cap on top of the four posts.

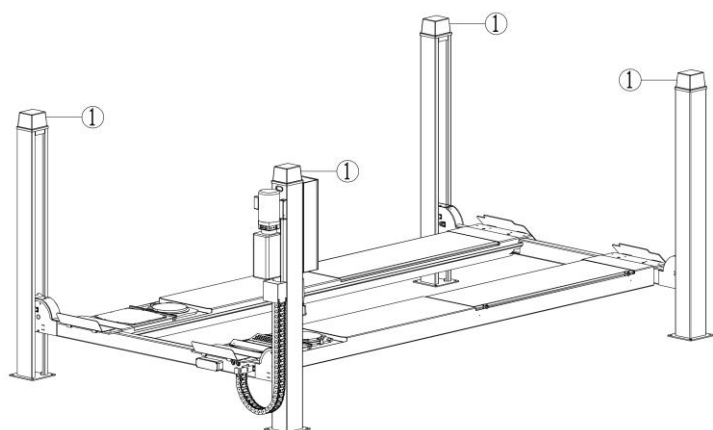

1 Post cap

Step 9: Connect the electrical and hydraulic system.

Refer to electrical and hydraulic connection diagrams before making connection.

Attention: electrical system connection must be done by licensed technicians. (For three phase power supply, if the lift doesn't raise and the motor may turn in the wrong direction, in such event, interchange wires U, V in the control cabinet).

1. Make the oil hoses of the lift go through the right side hole reserved on the cross beam. And then, have all the hoses and cables orderly go into the "Tank Chain".

Have all the hoses and cables orderly go through the outlet of holder B and route them as per the following drawing (left side)

Fix the hoses and cables protection covers with M6*35 bolts thereafter.

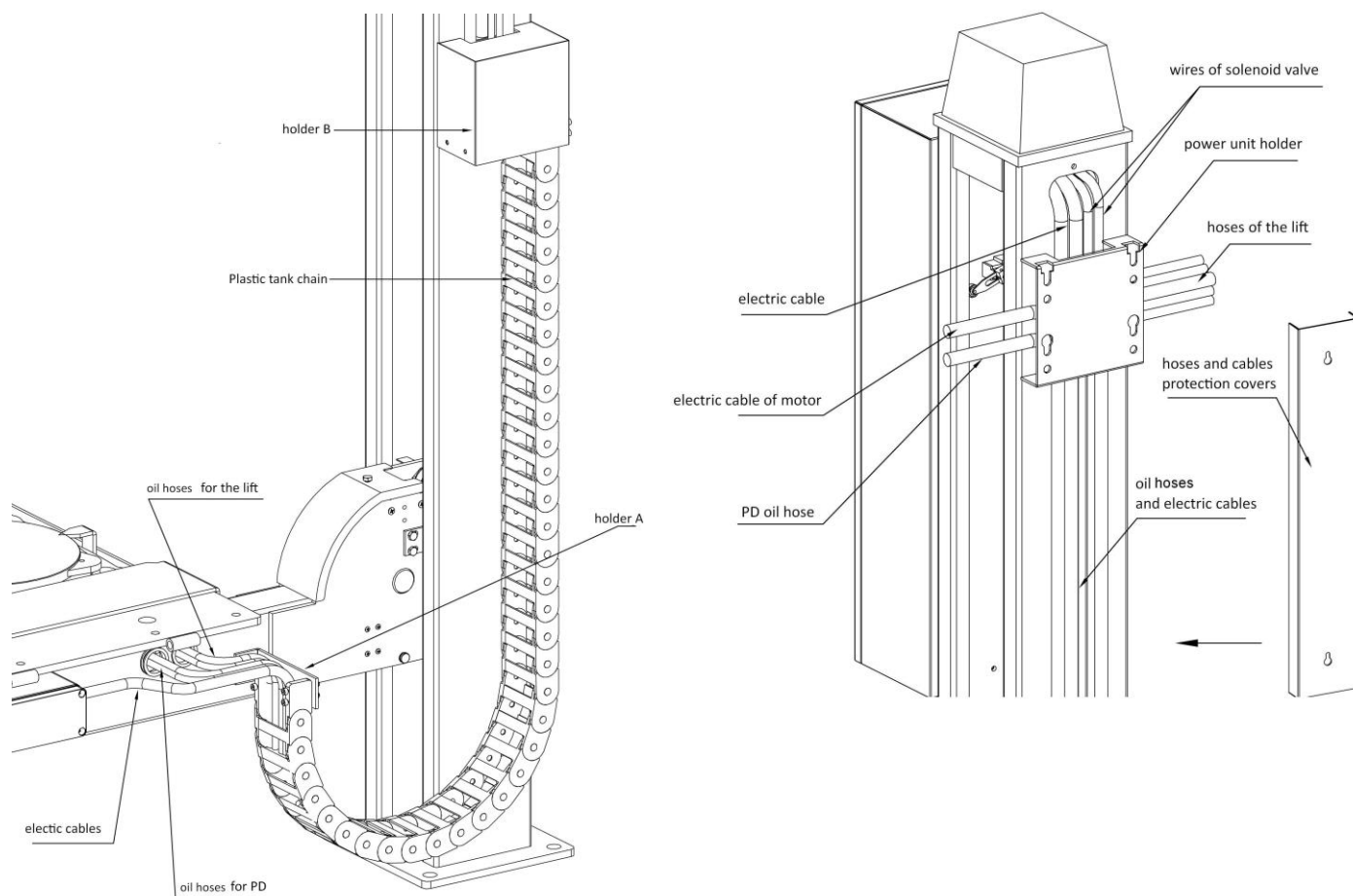

2. Fix the power unit and control box on to the post.

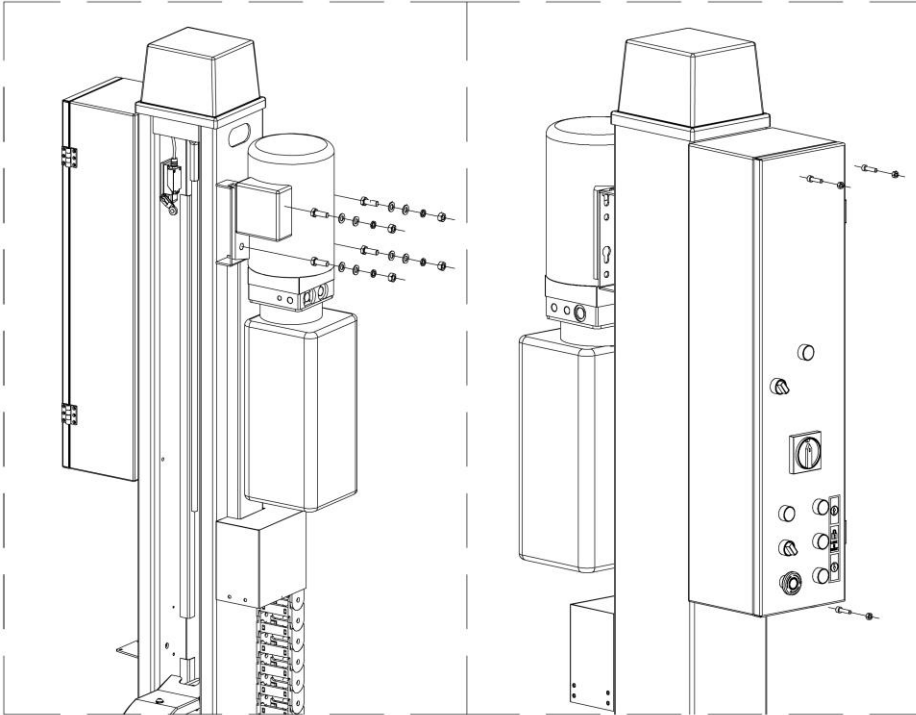

3. Connect oil hoses as per Annex 2.

4. Connect electrical wires to the control box as per Annex 3.

Step10: Fill with hydraulic oil (only fresh and clean oil is allowed)

ONLY CLEAN AND FRESH OIL ONLY .Lift must be fully lowered before changing or adding hydraulic oil.

Pour 10 liters anti-abrasion hydraulic oil into the oil tank. The level of oil shall reach the tippets volume mark of the tank.

Run the lift for several cycles and add more oil until the lifting platform can reach its maximum height.

Note: It is recommended to use HM NO.46 hydraulic oil. Use HM NO.32 hydraulic oil when average temperature is below 10°C.

Change the oil 6 months after initial use and change once per year thereafter.

Step 11: Levelling

Attention: No vehicle on platforms when leveling.

1. Firstly, level the platforms when mechanical safety locks are disengaged.

Switch on and press the UP button when the green power indicating light is on. When the steel cable has been tightened, measure if the two platforms are of the same height from the ground with a leveling pipe. If not, adjust screw ② fixed on top of the power side post.

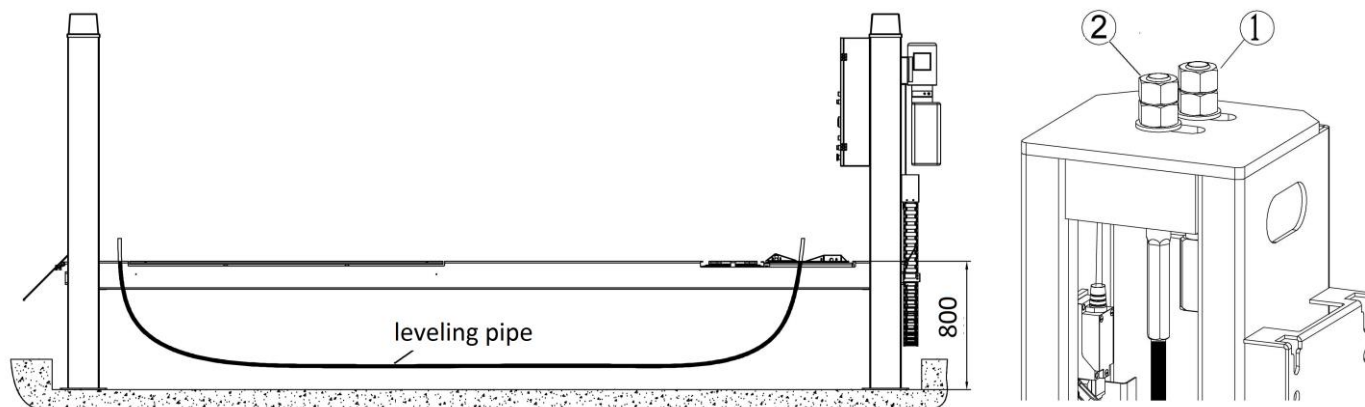
2. Secondly, level the platforms after mechanical safety locks are engaged.

Raise the platform about 750mm-800mm high and check if the safety blocks in the four posts could be engage synchronously. If not, adjust screw ① to ensure the synchronization.

Step 12: Adjust cable slack protection limit switches.

Make the platform be locked at height of 800mm and adjust the limit switch as showed in the following drawing with hex socket spanner (3mm)

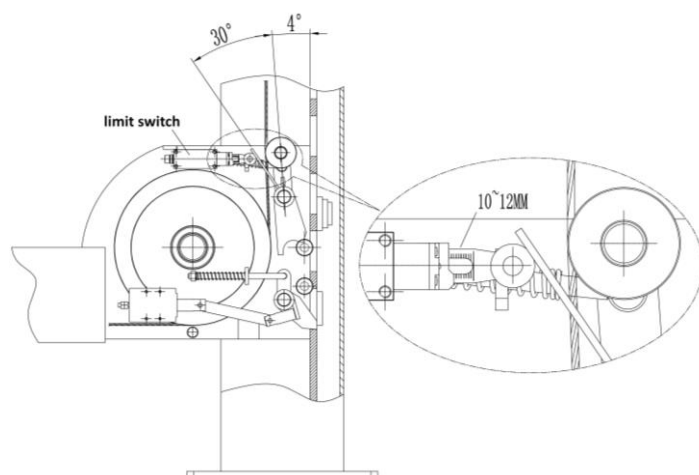
Step13: Fix the expansion bolts

Refer to 3.5 and adjust the distance between posts before drilling holes for expansion bolts.

1. Drill anchor holes for expansion bolts on the installation foundation with an electrical drill. Make sure to drill vertically.
2. Remove thoroughly the debris and dust in holes and ascertain that the posts stay right upon the circle previously marked by chalk.
3. Hammer in and secure expansion bolts.

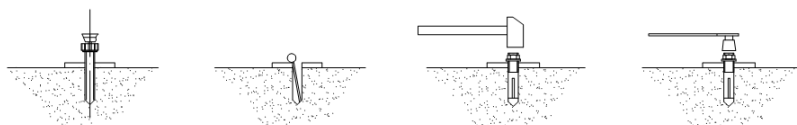

4.4. Items to be checked after installation

S/N	Check items	YES	NO
1	Screw torque of expansion bolts : 60-80N•m;		
2	Rising speed ≥ 20 mm/s;		
3	Noise with rated load ≤ 75 dB;		
4	Grounding resistance: not bigger than 4 Ω ;		
5	Height difference of the two platform ≤ 5 mm;		
6	Mechanical locks are robust and synchronized when running with rated load ;		
7	If the control button works as “hold to run”?		
8	If limit switches work well?		
9	If grounding wire is connected?		
10	If the lift rises and lowers smoothly?		
11	If there is no abnormal noise during running with rated load?		
12	If there is no oil leakage when running with rated load?		
13	If expansion bolts, nuts or circlips are well secured?		
14	If max lifting height is 1830mm?		
15	If Safety advices, name plate and logos are clear?		

OPERATION INSTRUCTIONS

5.1 Precautions

5.1.1 Check all the joints of oil hose. Only when there is no leakage, the lift can start work.

5.1.2 The lift, if its safety system malfunctions, shall not be used.

5.1.3 The machine shall not lift or lower an automobile if its center of gravity is not positioned midway of the platforms.

5.1.4 Operators and other personnel concerned should stand in a safety area during lifting and lowering process.

5.1.5 When the platforms rise to the desired height, switch off the power at once to prevent any mal-operation done by unconcerned people.

5.1.6. Make sure the safety lock of the lift is engaged before start working under the vehicle and no people under the vehicle during lifting and lowering process.

5.2 Descriptions of control panel

Control panel for lifting system with PD

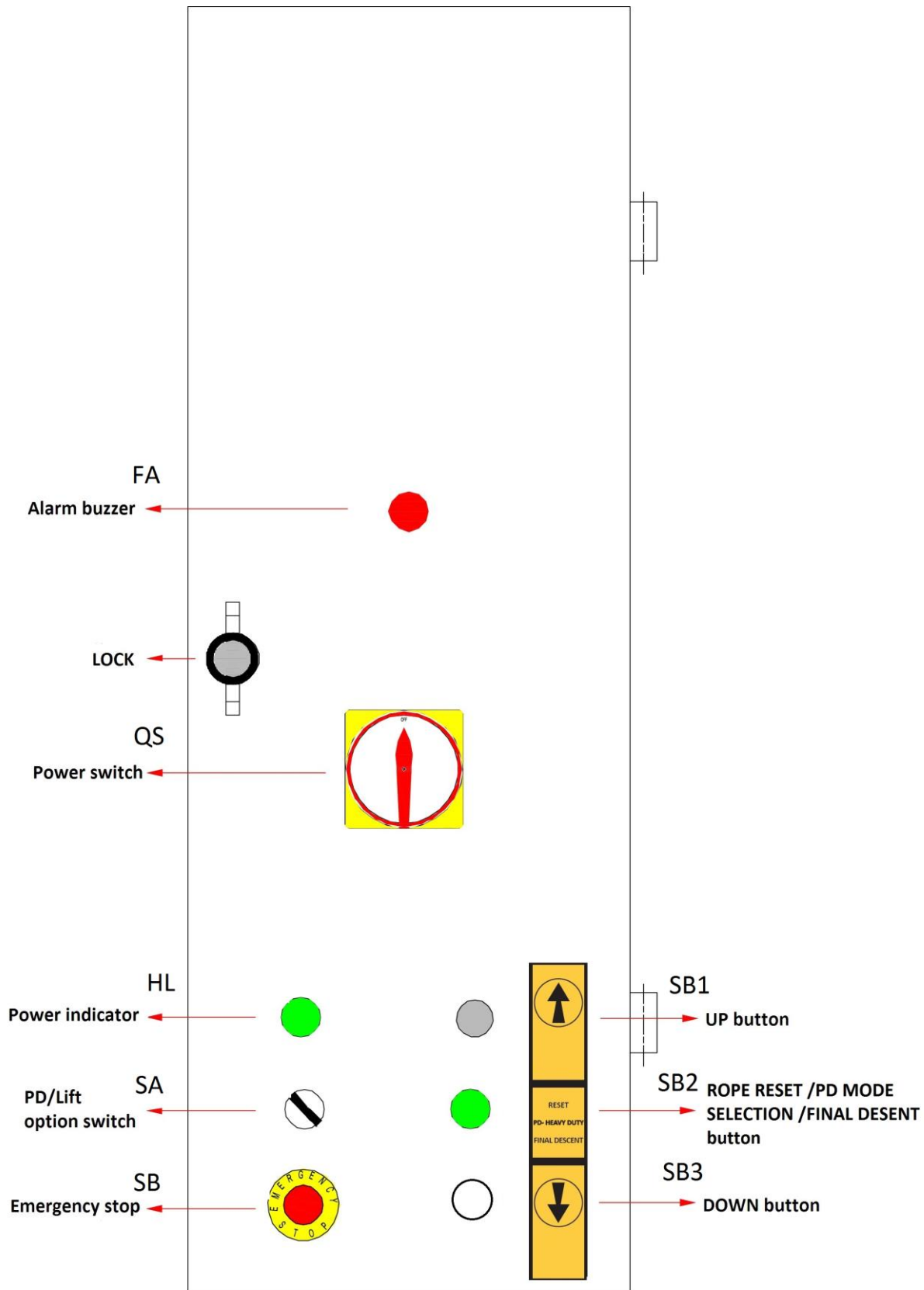

Control panel for lifting system without PD

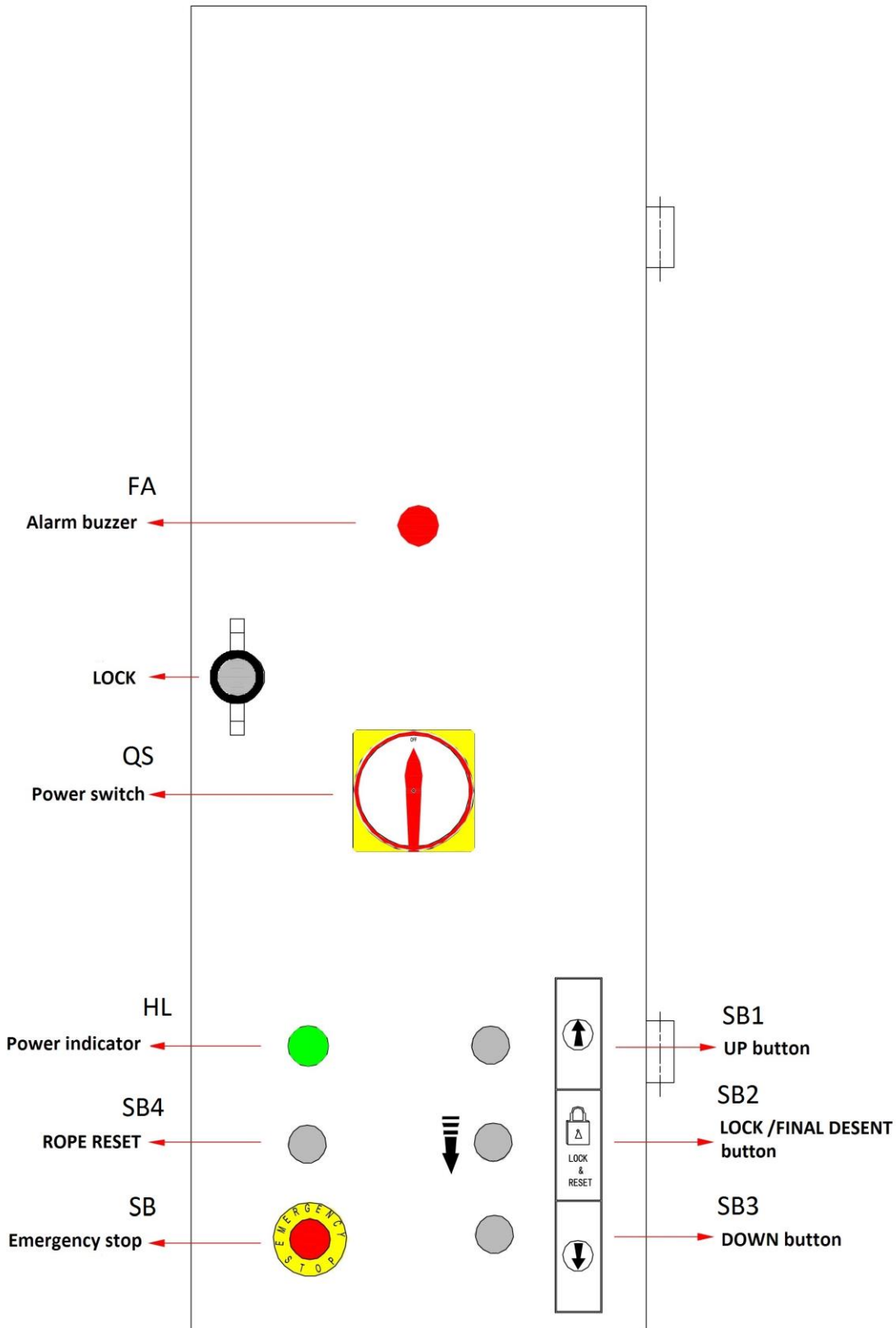

Functions Descriptions

Name	Function
Alarm buzzer	Low height warning
Power switch	Power on/ off
Power indicator	Display if electricity is connected
UP button	Control the rising movement
Door Lock	Lock the control cabinet
ROPE RESET/ PD MODE SELECTION /FINAL DESCENT button (Only applicable to system with PD) LOCK / FINAL DESCENT button (Applicable to system without PD)	Press this button to lower / lock the platform into the mechanical safety devices. Push this button to complete final descend to the ground after stopping at approx. 300mm from the ground. Meanwhile, alarming warning will be heard. 2. When the cable slack protection system activates, the platform will not be able to move up or down. In this case, press this button to reset the steel cable system and make the lift run normally. 3 Select the PD mode as per different types of vehicle. (the original mode is for light vehicles)
Reset button (Applicable to system without PD)	When the cable slack protection system activates, the platform will not be able to move up or down. In this case, press this reset button and UP button simultaneously to reset the steel cable system and make the lift run normally.
DOWN button	Control the lowering movement
PD/Lift option switch (Only applicable to system with PD)	Shift working status from lift to PD or PD to lift
Emergency stop	Ensure quick stop in emergency situations

5.3 Flow chart for operation

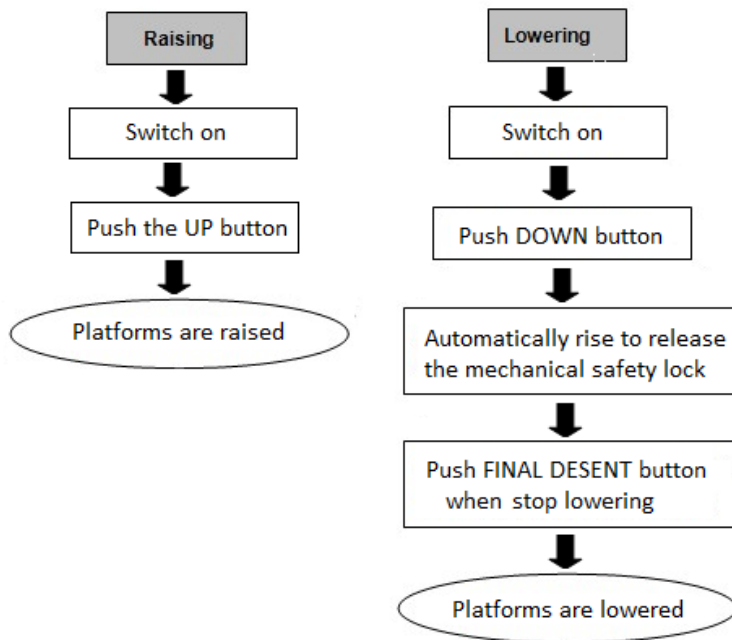

5.4 Operation instructions

5.4.1 Operation instructions for the lift

Turn the selection switch to the state of "LIFT". (ONLY Applicable to lifting system with PD)



The lift must be only used in a static position for lifting and lowering vehicles.

Only use this lift on a surface that is stable and capable of sustaining the load. Do not install the lift on any asphalt surface.

To avoid personal injury and/or property damage, permit only trained personnel to operate the lift. After reviewing these instructions, get familiar with lift controls by running the lift through a few cycles before loading vehicle on lifting platform.

Raise the lift

Make sure vehicle is neither front nor rear heavy and center of balance should be centered over the lift.

1. Turn on the power switch.
2. Park the vehicle on the platforms to ensure its gravity is positioned midway of the platforms.
3. Push the UP button until rise to the expected height.
4. Before perform any service around or under the vehicle, push the safety lock button to ensure the mechanical safety lock is fully engaged. Turn off the power so as to avoid any wrong operation done by irrelevant personnel and check again the stability of the vehicle.

Lower the lift

Pay careful attention that all personnel and objects are kept clear.

1. Turn on the power switch.
2. Push "DOWN" button to lower the lift. It will stop lowering at proper height off the ground.
3. Push "FINAL DESCENT" button to continue lowering the platforms which accompanies with safety alarming buzz.

5.4.2 Operation instructions for the optional PD system

Capacity: 3000kg

Turn the selection switch to PD mode.

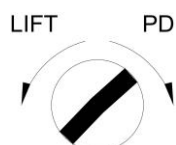

The PD is designed for powered moving the wheels of the vehicle enabling inspection of suspension and steering joints

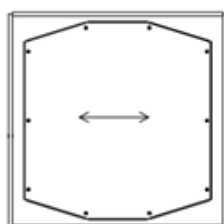
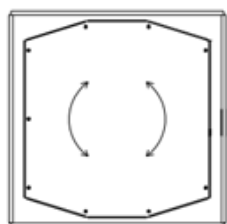

1. Ensure vehicle is positioned centrally on the PD plates, steering lock off and engine running (to enable the power steering system)
2. Raise lift to desired working height to enable you to clearly view the suspension / steering joints to be inspected and park the lift into the mechanical locking system.

4. Using either the inspection torch or the key fob,

Pressing and holding the left button will operate the nearside PD plate (rotation of steering) from extent to extent, once button released plates will return to the center position.

Pressing and holding the Right button will operate the offside PD plate (side to side movement) from extent to extent, once button released plates will return to the center position.

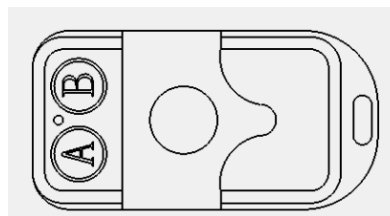
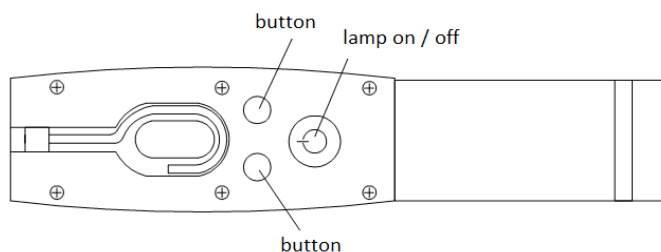

If the rechargeable LED torch style remote control is chosen allow to charge for 3 hours before initial use, always replace it back to its holder to have it charged when not in use.

Attention: the remote control works within a radius of 5.7m from the main control box.

5.5 Emergency lowering in case of no power

In the case the safety lock is not engaged:

1. Push the front rod of the four electromagnets under the cross beam to have the four safety blocks released from the safety rods.

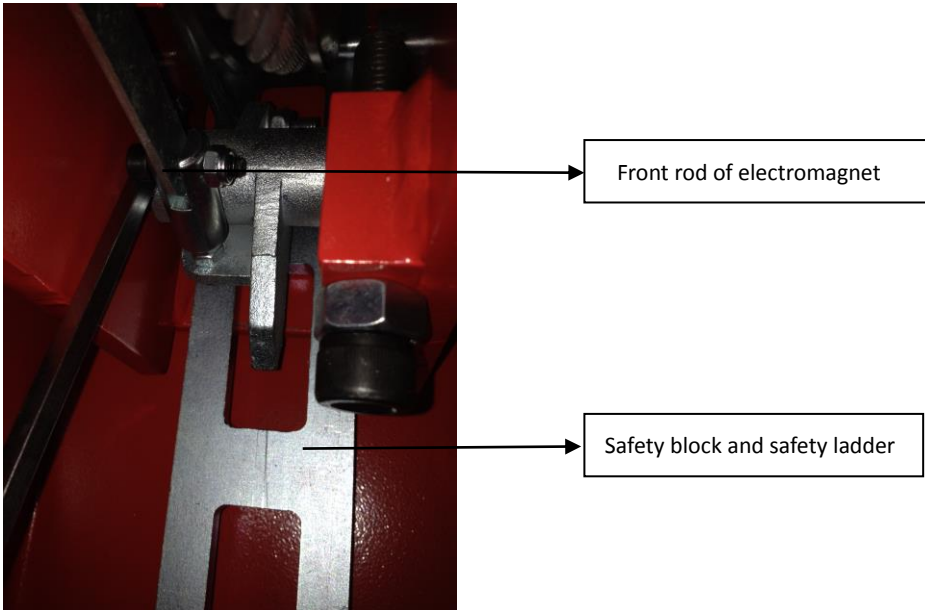

2. Press and screw loose counter-clockwise the unloading valve to lower the platform.

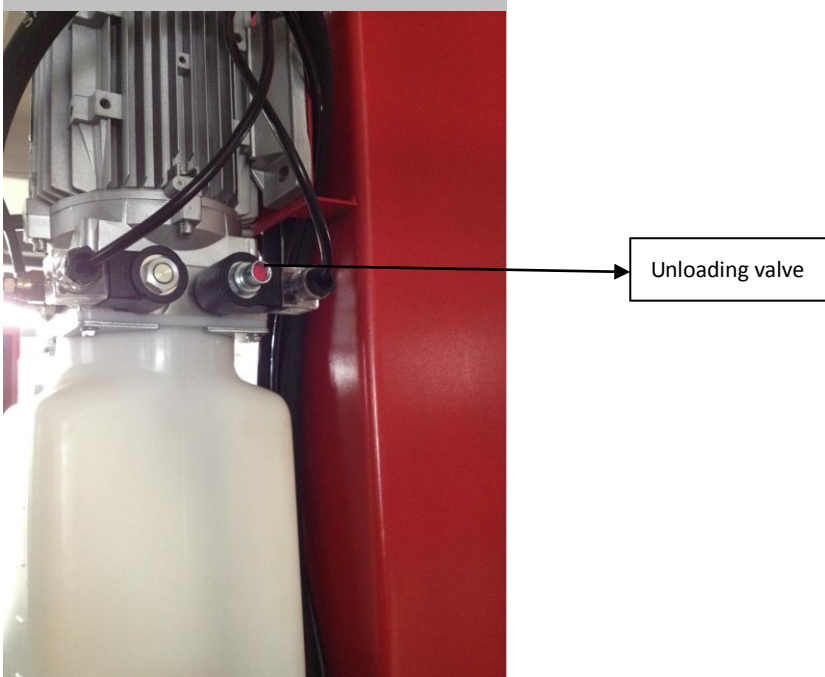

TROUBLE SHOOTING

ATTENTION: If the trouble could not be fixed by yourself, please do not hesitate to contact us for help .We will offer our service at the earliest time we can. By the way, your troubles will be judged and solved much faster if you could provide us more details or pictures of the trouble.

TROUBLES	CAUSE	SOLUTION
Abnormal noise	Abrasion exists on insider surface of the posts.	Grease the inside of the post.
	Trash in the post.	Clear the trash
Motor does not run and will not rise	Loose wire connection	Check and make a good connection.
	Blown motor.	Replace it.
	Damaged limit switch or its wire connection is loose.	Adjust or replace the limit switch.
Motor runs but will not rise	The motor run reversely.	Check the wire connection.
	Overflow valve is not well screwed up or jammed.	Clean or make adjustment
	Damaged gear pump.	Replace it.
	Too low oil level.	Add oil.
	The hose connection is loose.	Tighten it.
	The cushion valve is not well screwed up or jammed.	Clean or make adjustment
Platforms go down slowly after being raised	The oil hose leaks.	Check or replace it.
	Untightened oil cylinder.	Replace the seal.
	The single way valve leaks.	Clean or replace it.
	The overflow valve leaks.	Clean or replace it.
	Solenoid valve fails to work well.	Clean or replace it.
	Slack steel cable	Check and adjust the tightness.
Rising too slow	Jammed oil filter	Clean or replace it.
	Too low oil level.	Add oil.
	The overflow valve is not adjusted to the right position.	Make adjustment.
	Too hot hydraulic oil (above 45°) .	Change the oil.
	Abraded. Seal of the cylinder	Replace the seal.
	Inside surface of the posts is not well greased.	Add grease.
Lowering too slow	Jammed throttle valve	Clean or replace.
	Dirty hydraulic oil	Change the oil.
	Jammed anti-surge valve	Clean it.
	Jammed oil hose	Replace it.
The steel cable is abraded	No grease at installation or out of lifetime	Replace it.

MAINTENANCE

Easy and low cost routine maintenance can ensure the lift work normally and safely. Following are requirements for routine maintenance. You may decide the frequency of routine maintenance by consulting your lift's working conditions and time.

THE FOLLOWING PARTS NEED TO BE LUBRICATED WITH LITHIUM GREASE.

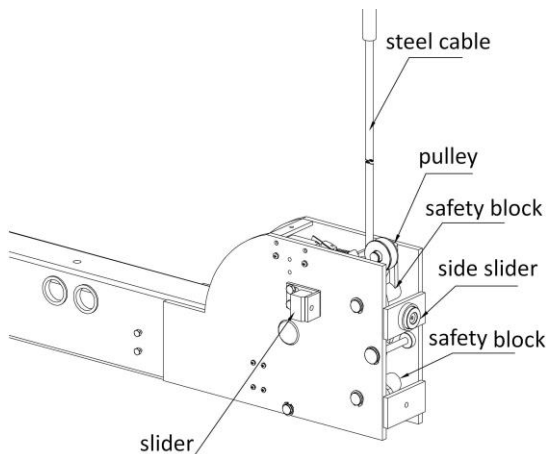

6.1 Daily checking items before operation

The user must perform daily check. Daily check of safety latch system is very important – the discovery of device failure before action could save your time and prevent you from great loss, injury or casualty.

- Before operation, judge whether the safety latches are engaged by sound.
- Check whether oil hose well connected and whether it leaks or not.
- Check the connections of chain and steel cable and check the power unit.
- Check whether plug bolts firmly screwed.
- Check if safety teeth and safety block matched well or not.

6.2 Weekly checking items

- Check the flexibility of moving parts.
- Check the working conditions of safety parts.
- Check the amount of oil left in the oil tank. Oil is enough if the carriage can be raised to highest position. Otherwise, oil is insufficient.
- Check whether plug bolts firmly screwed.

6.3 Monthly checking items

- Check whether plug bolts firmly screwed.
- Check the tightness of the hydraulic system and screw firm the joints if it leaks.
- Check the lubrication and abrasion circumstance of axial pins, carriages, lifting arms and other related parts and replace in time with new ones if they failed to work well.
- Check the lubrication and abrasion circumstance of steel cable.

6.4 Yearly checking items

- Empty the oil tank and check the quality of hydraulic oil.
- Wash and clean the oil filter.

If users strictly follow the above maintenance requirements, the lift will keep in a good working condition and meanwhile accidents could be avoided to a large extent.

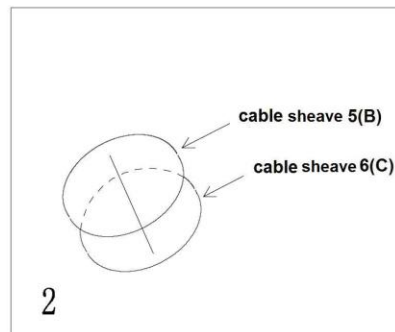
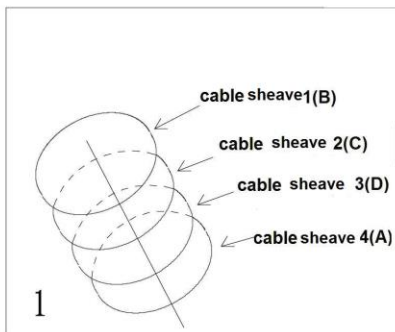
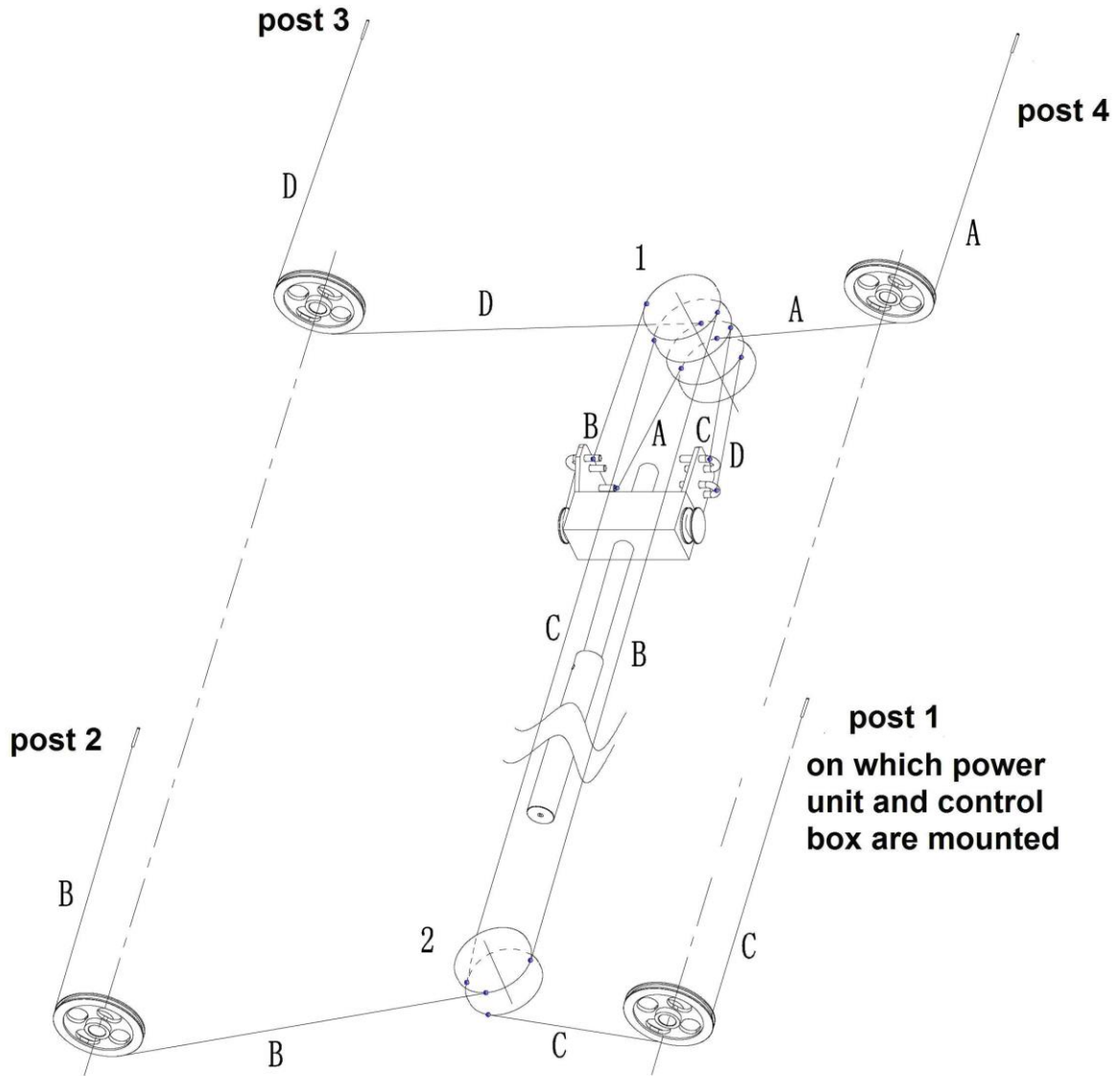
Annex 1, Steel cable connection

Annex 2, Electrical schemes and parts list

Electrical schemes with PD

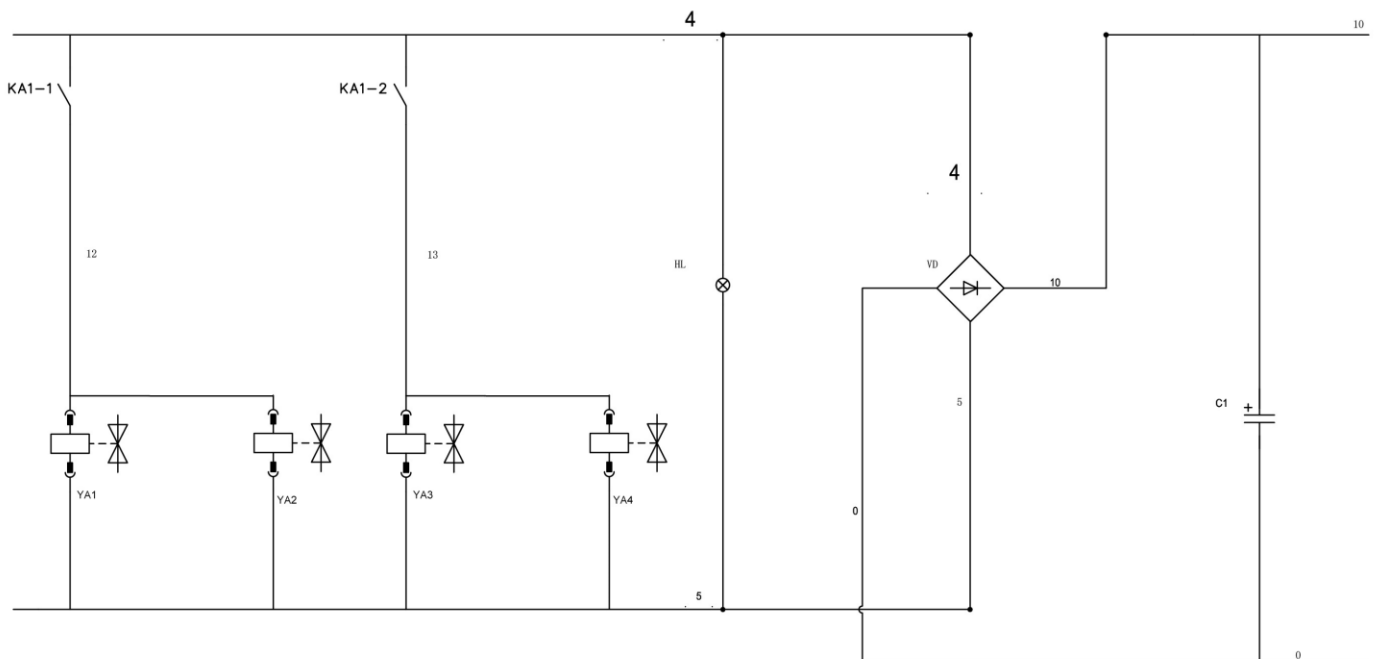
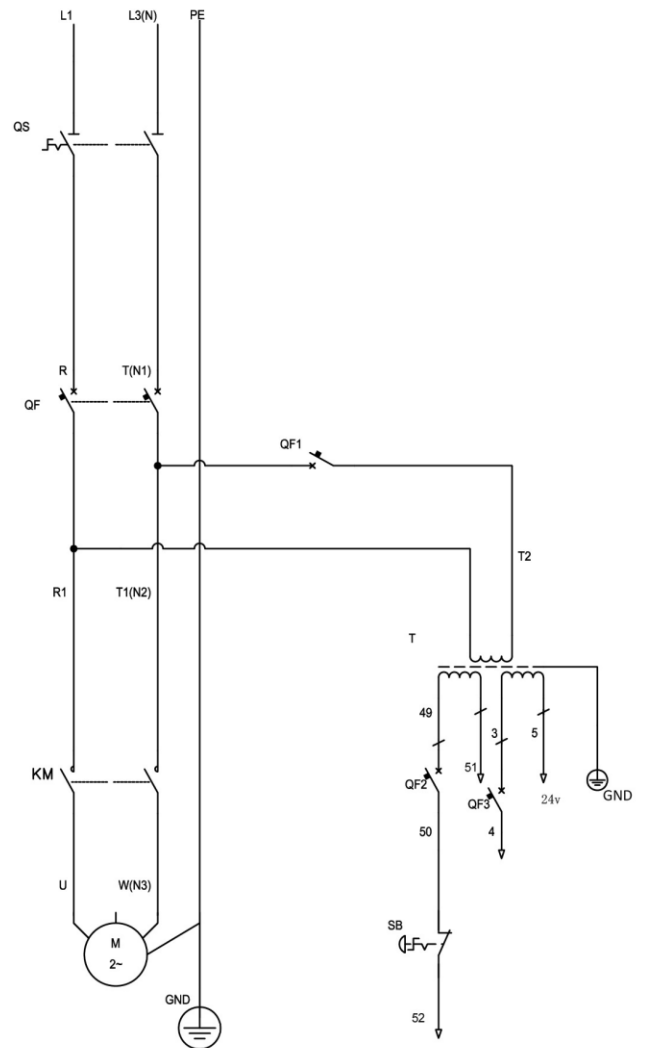
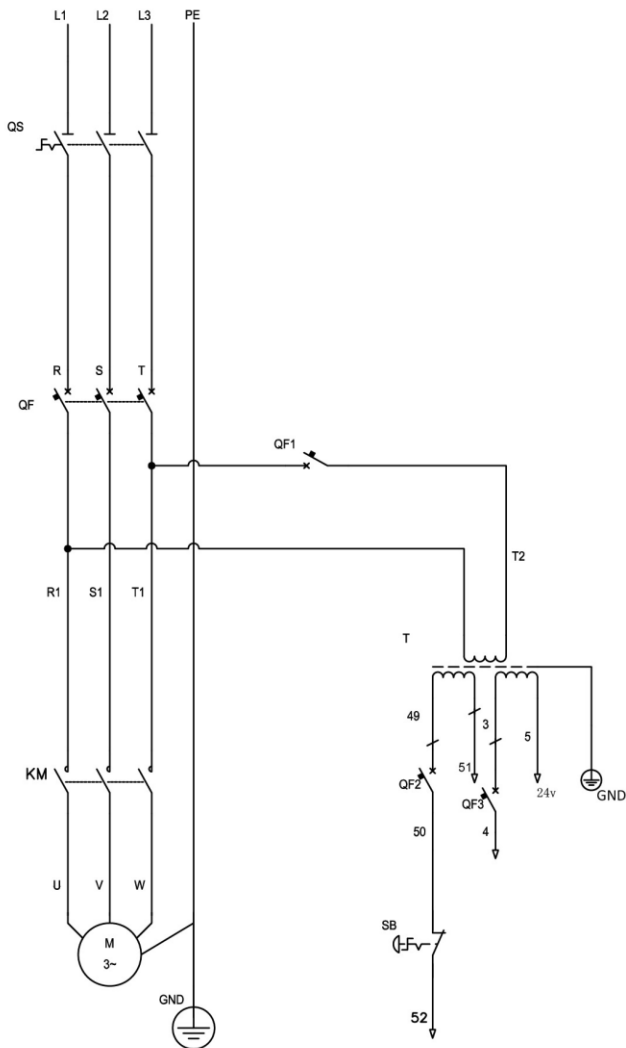

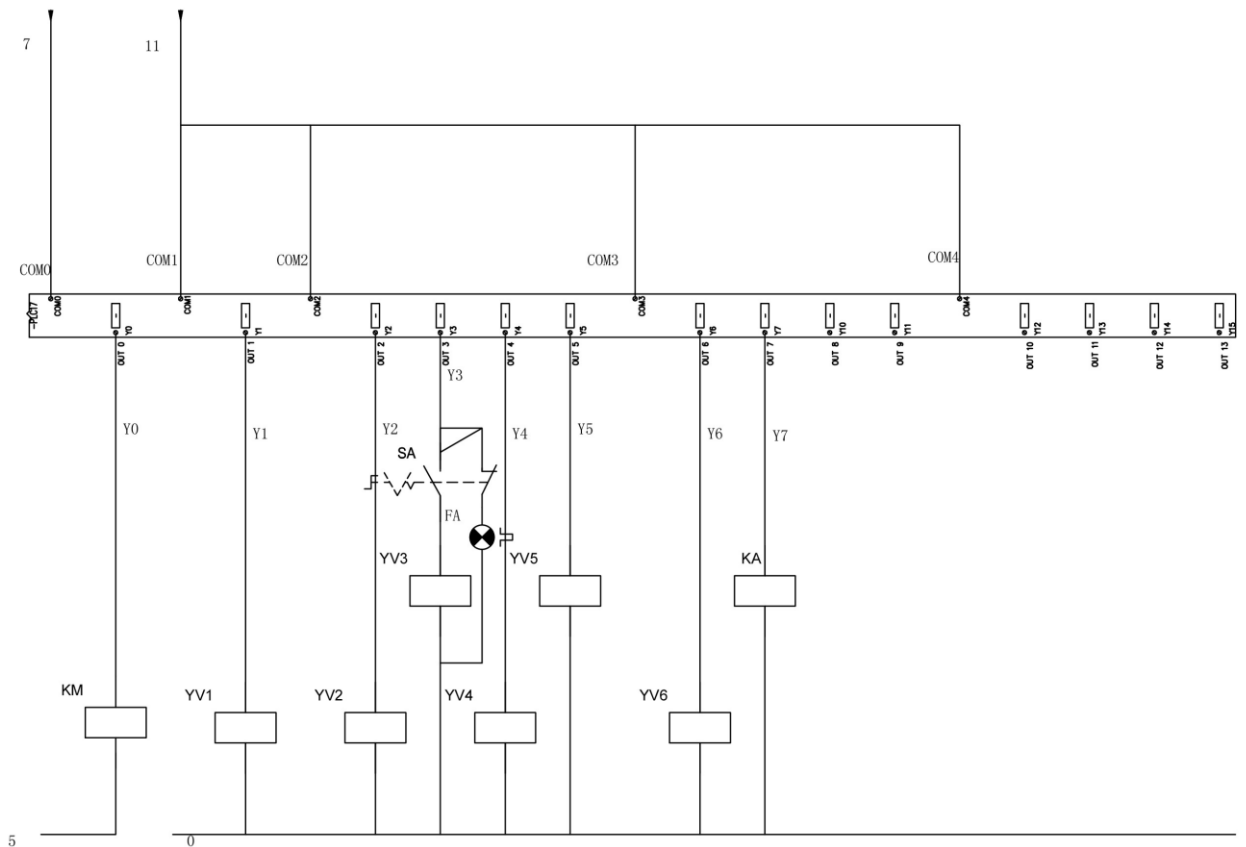
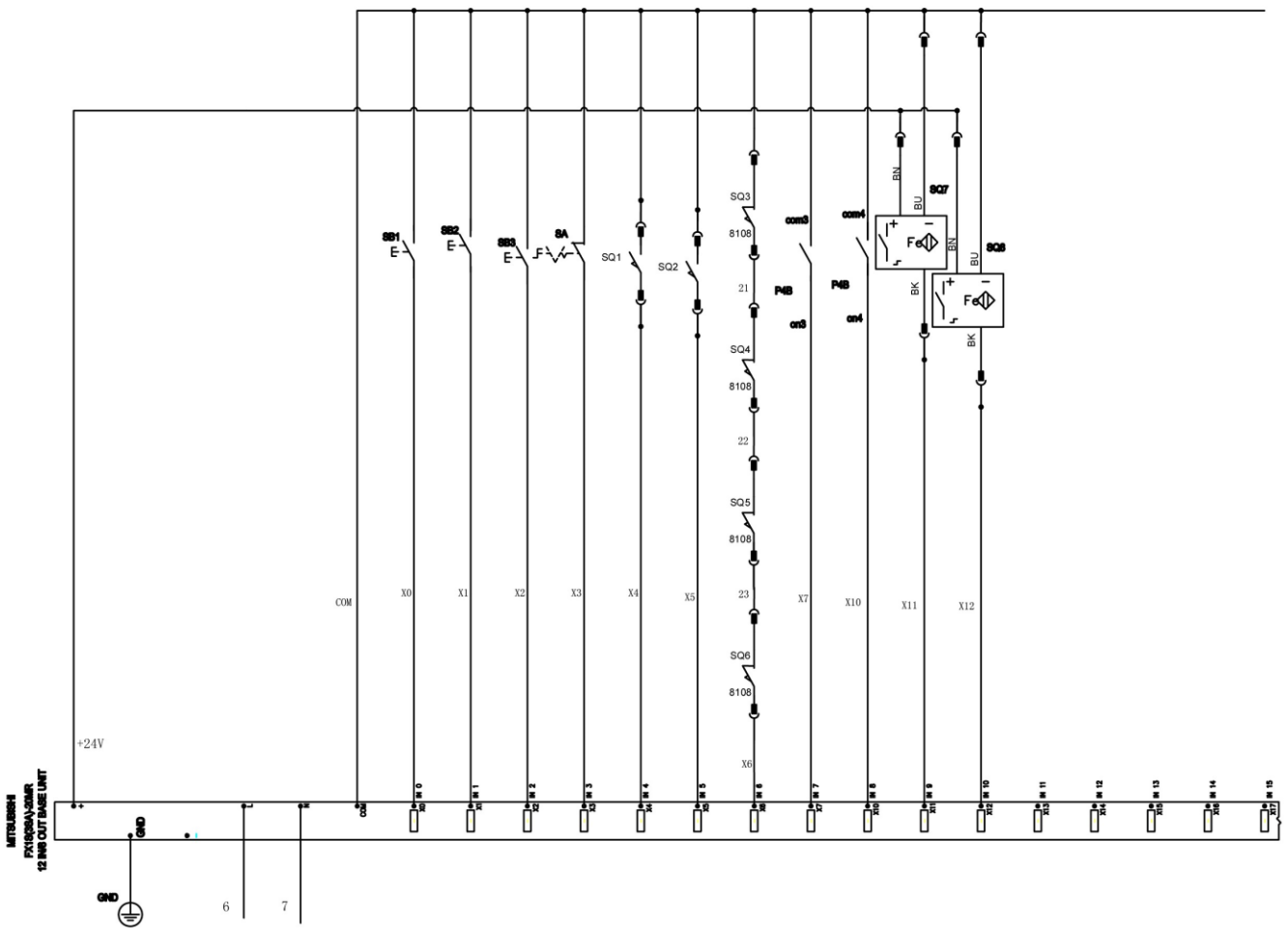

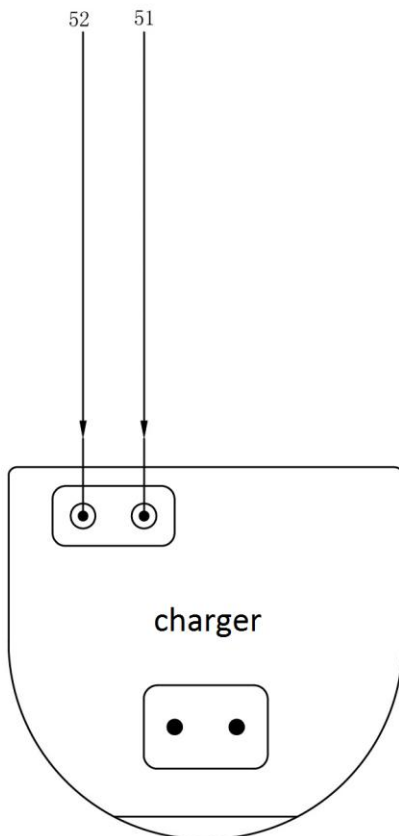
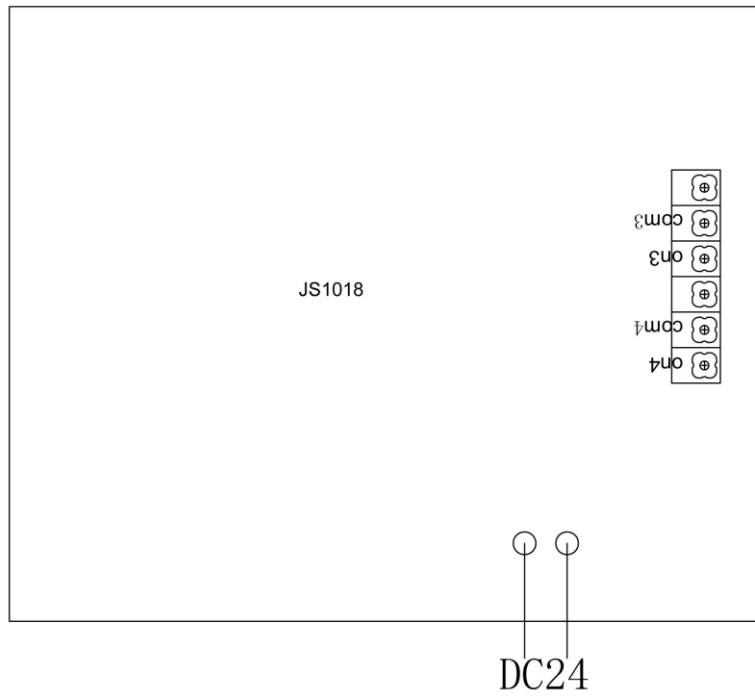

Technical data of the formal charger : INPUT:AC100-240V 50-60HZ
OUTPUT:DC-4.2V 1500mA MAX

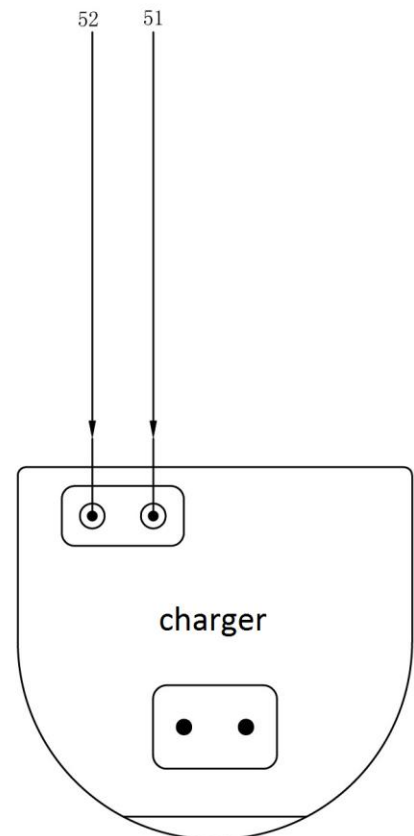

Technical data of the new charger : INPUT:AC220-240V 50-60HZ
OUTPUT:DC-7.4V 1200mA MAX

Electrical connections with PD

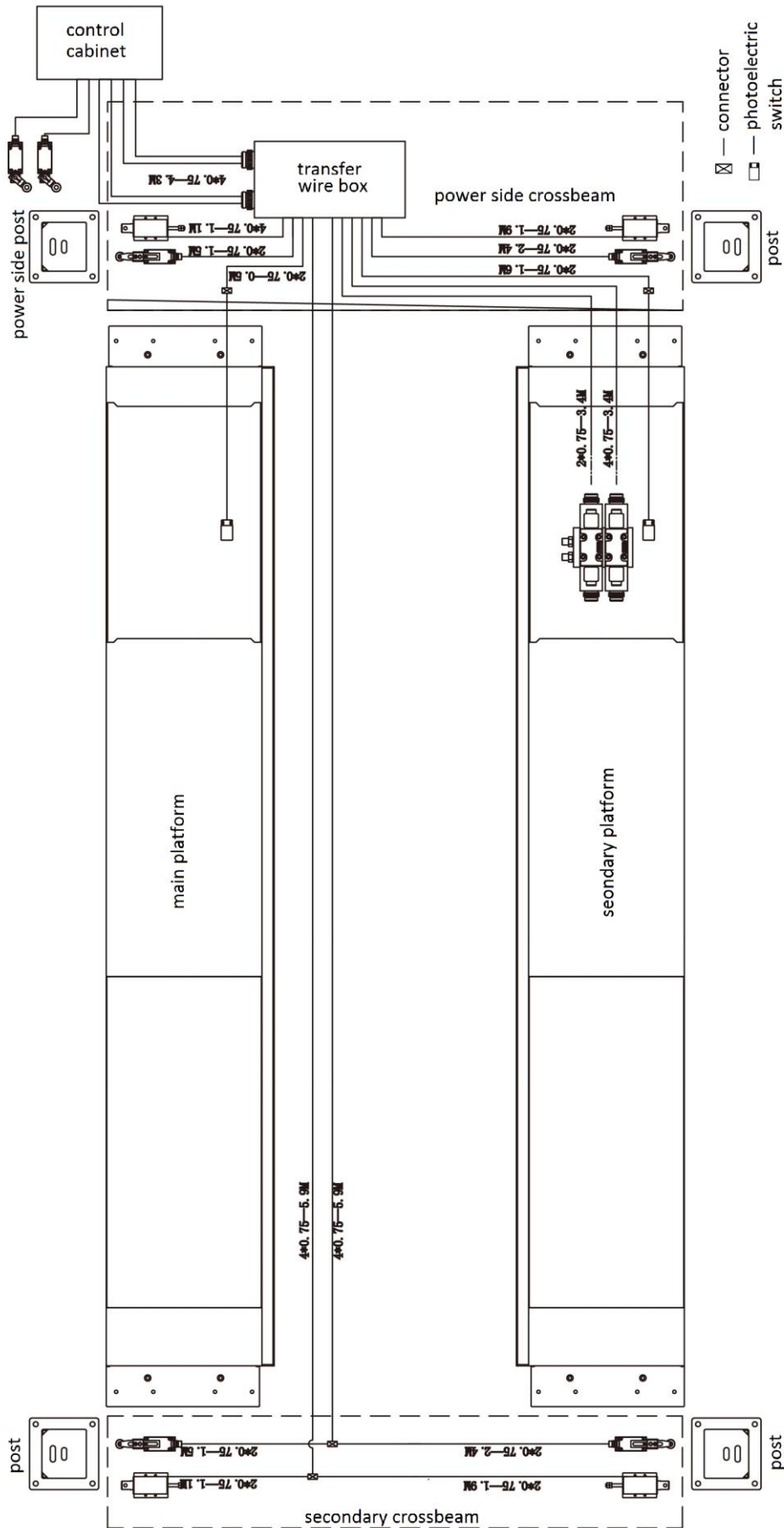

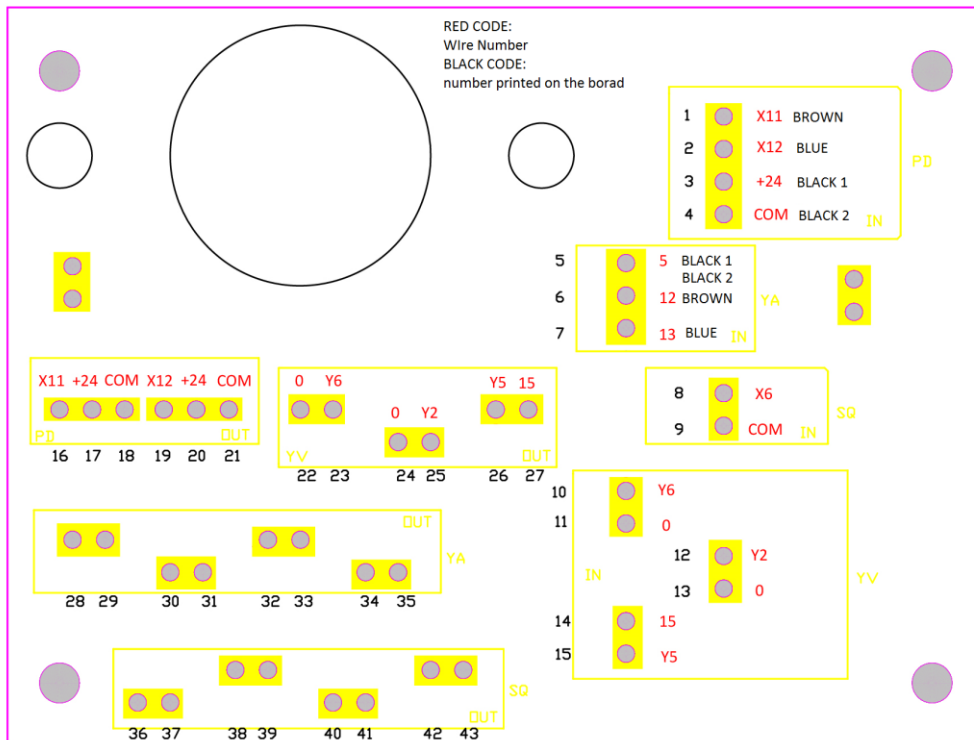

PCB connector Table

Number Printed on the Board	Terminal Specification	Color	Wire terminals	IN/OUT	CODE for wire terminals
1.2.3.4	4P	BLACK	control box- PD	IN	X11, X12.+24.COM
5.6.7	3P	BLUE	control box- electromagnet	IN	5.12.13 (two NO.5 wires connected)
8.9	2P	GREEN	control box- limit swich (out of level protection)	IN	X6.COM
10.11	2P	ORANGE	control box- PD valve	IN	Y6.0
12.13	2P	ORANGE	control box- PD valve	IN	Y2.0
14.15	2P	ORANGE	control box- PD valve	IN	15.Y5
16.17.18	3P	BLACK	platform-PD	OUT	X11.+24.COM
19.20.21	3P	BLACK	platform-PD	OUT	X12.+24.COM
22.23	2P	ORANGE	platform- PD valve	OUT	0.Y6
24.25	2P	ORANGE	platform- PD valve	OUT	0.Y2
26.27	2P	ORANGE	platform- PD valve	OUT	Y5.15
28.29	2P	BLUE	post -electromagnet	OUT	NONE
30.31	2P	BLUE	post -electromagnet	OUT	NONE
32.33	2P	BLUE	post -electromagnet	OUT	NONE
34.35	2P	BLUE	post -electromagnet	OUT	NONE
36.37	2P	GREEN	post-limit switch 8108	OUT	NONE
38.39	2P	GREEN	post-limit switch 8108	OUT	NONE
40.41	2P	GREEN	post-limit switch 8108	OUT	NONE
42.43	2P	GREEN	post-limit switch 8108	OUT	NONE

Electrical parts list for lifting system with PD

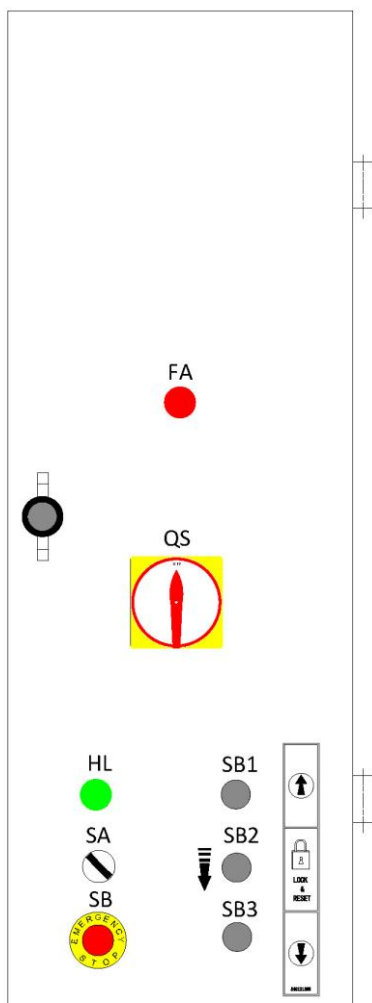

Pos.	CODE	Name	Qty
T	320102023	Transformer(DUAL 400-230V)	1
	320101081	Transformer (400V)	1
SQ1;SQ2	320301009	Limit switch	2
SQ3-SQ6	320301011	Limit switch	4
SQ7;SQ8	320302002	Proximity switch	2
SA	320303020	Selection switch	1
QS	320304001	Power switch	1
SB1	320401014	Button	1
SB2	320401022	Button	1
SB3	320401041	Button	1
	320401021	Metal button	2
SB	320402002	Emergency stop	1
	320503002	Ground terminals	1
	320505006	Ground terminal	27
	320505011	Retaining chip	2
KA	320601005	Relay feet fixer	1
	320601009	Relay holder	1
QF	320801001	Circuit breaker	1
QF	320801003	Circuit breaker(DUAL)	1
QF1	320803005	Circuit breaker	1
QF2	320803001	Circuit breaker	1
QF3	320803007	Circuit breaker	1
KM	320901011	AC contactor	1
C	321001004	Capacitor	1
VD	321002001	Bridge Rectifier	1
	321003005	Remote controller 1	1
	321003006	Remote controller 2	1
	321003007	Receiver	1
HL	321201001	Power Indicator	1
	321201006	Torch	1
FA	321202001	Alarm Buzzer	1
PLC	321301002	Programmable controller	1
YA1-YA4	330310007	Electromagnet	4
	321203157	Circuit board	1

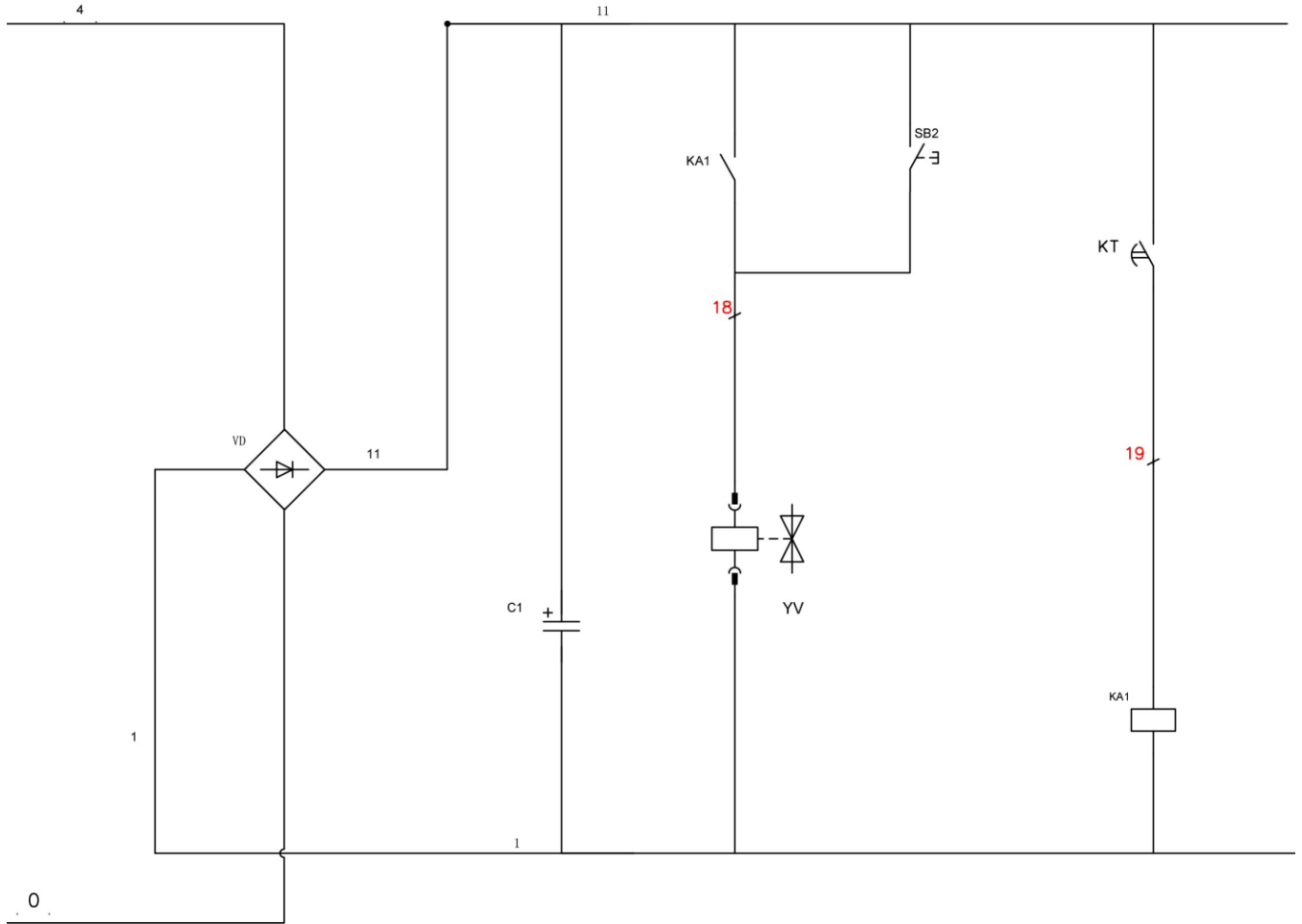

Electrical connections without PD

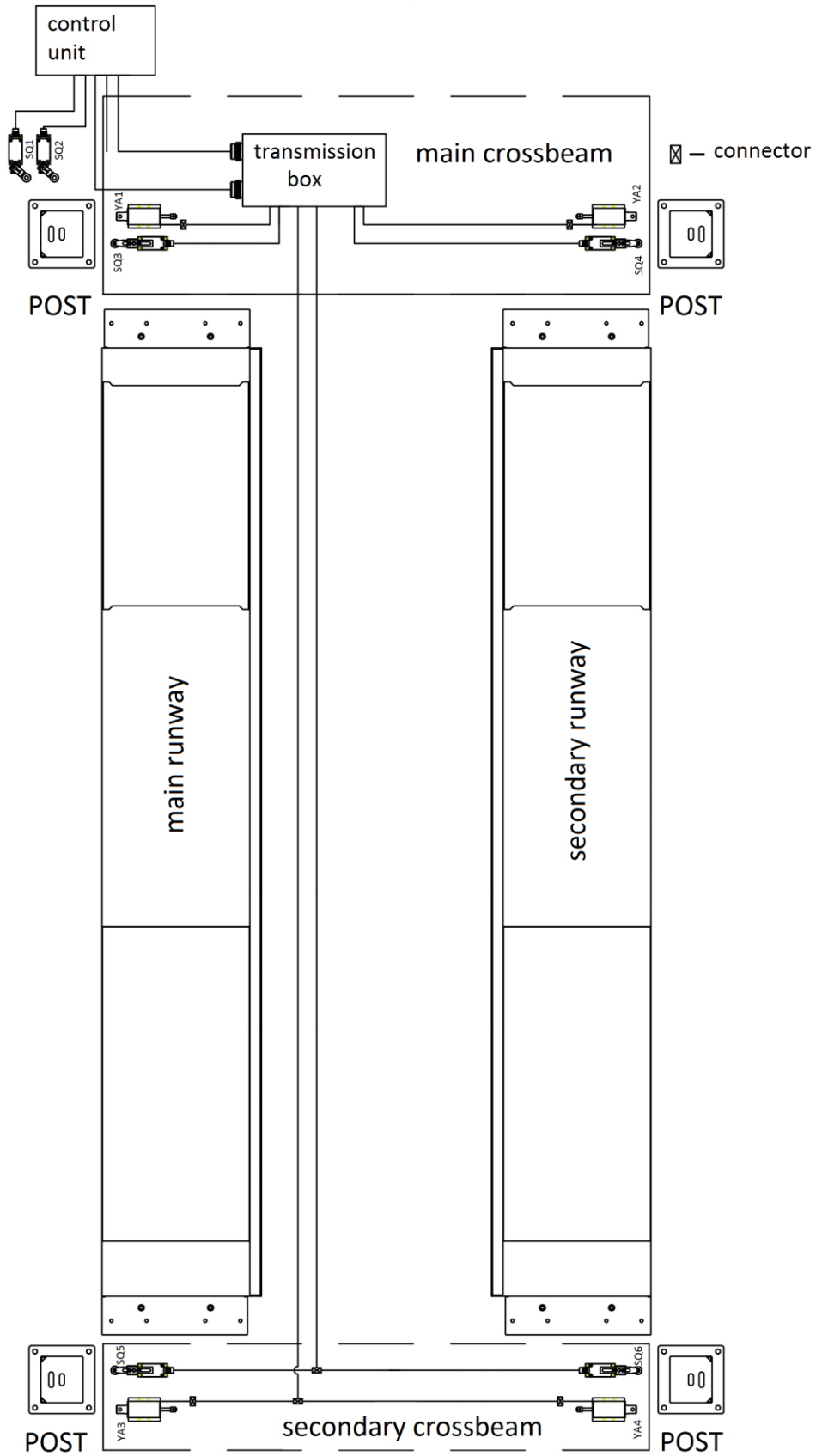

Electrical parts list for lifting system without PD

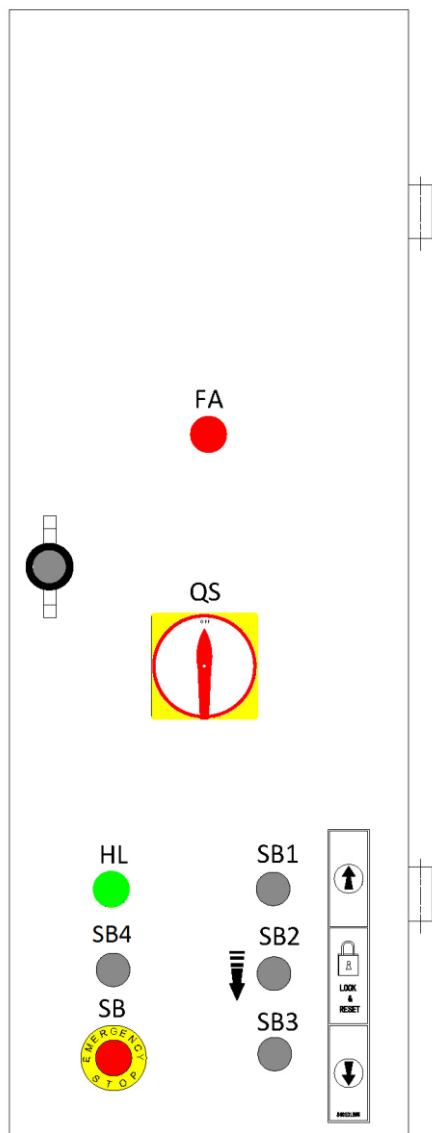

POS.	CODE	Name	Qty
T	320101075	Transformer(400V)	1
	320102020	Transformer(400-230V)	1
M		Motor 3.0kW	1
SQ1;SQ2	320301009	Limit switch 8104	2
SQ3-SQ6	320301011	Limit switch 8108	4
QS	320304001	Power switch	1
SB1	320401014	Button	1
SB2	320401022	Button	1
SB3	320101041	Button	1
SB4	320401038	Button	1
SB	320402002	Emergency stop	1
KA1	320601007	Relay	1
	320601010	Relay holder	1
	320601018	Relay fixer	2
KT	320602001	Time relay	1
	320602006	Time relay holder	1
	320602007	Time relay fixer	2
QF	320801001	Circuit breaker (3Ph)	1
	320801003	Circuit breaker (DUAL)	1
QF1	320803006	Circuit breaker	1
QF2	320803007	Circuit breaker	1
KM	320901011	AC contactor(3.0kW/DUAL)	1
C	321001004	Capacitor	1
VD	321002001	Bridge rectifier	1
HL	321201001	Power indicator	1
FA	321202001	Alarm buzzer	1
YA1-YA4	330310007	Electromagnet	4
	321203157	Printed circuit board	1

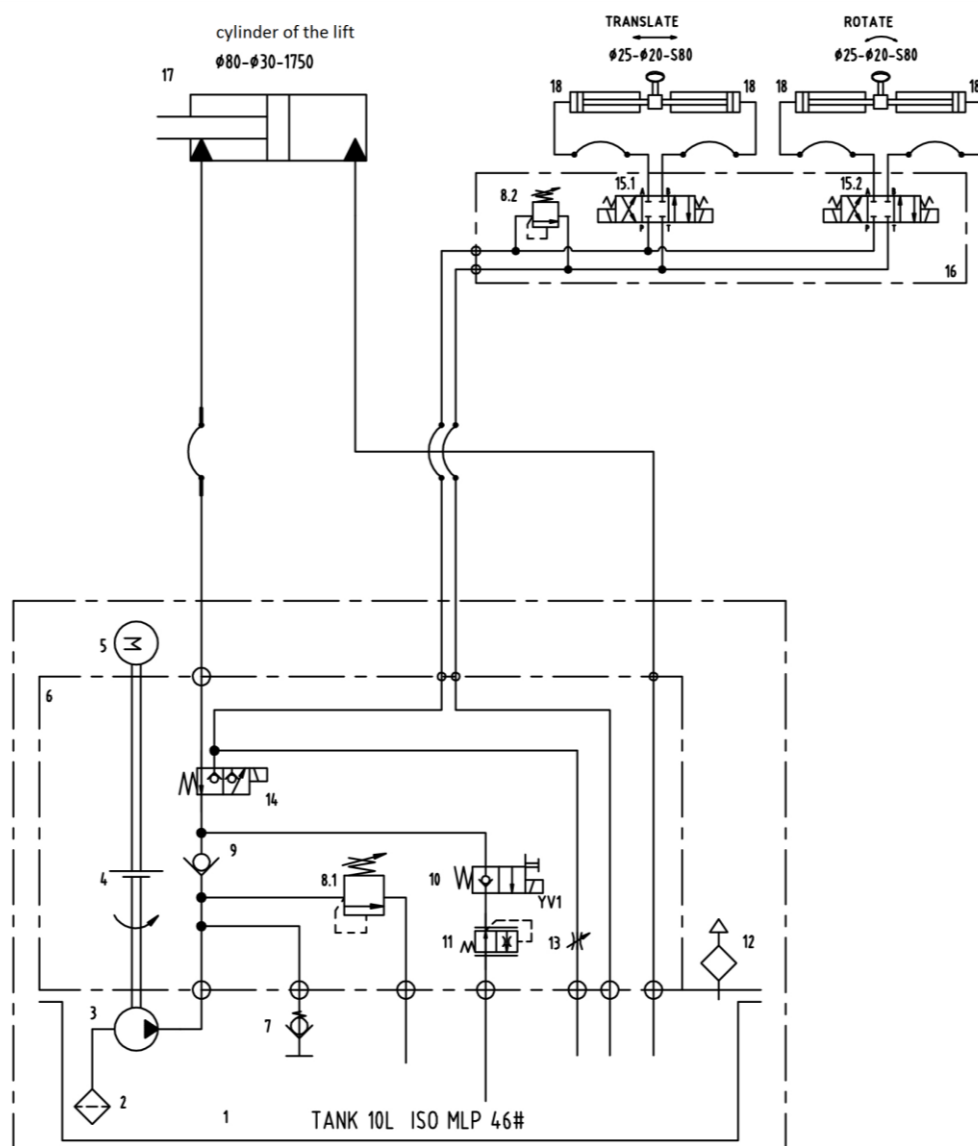
Annex 3, Hydraulic schemes and parts list
Hydraulic scheme with PD

- 1.oil tank
- 2.oil sucking filter
- 3.gear pump
- 4.coupling
- 5.motor
- 6.composite hydraulic block
- 7.cushion valve
- 8.over flow valve
- 9.single way valve
- 10.solenoid unloading valve
- 11.pressure supplement valve
- 12.tank cover
- 13.throttle valve
- 14.solenoid valve
- 15.solenoid valve
- 16.hydraulic block
- 17.cylinder of the lift
- 18.cylinder of PD

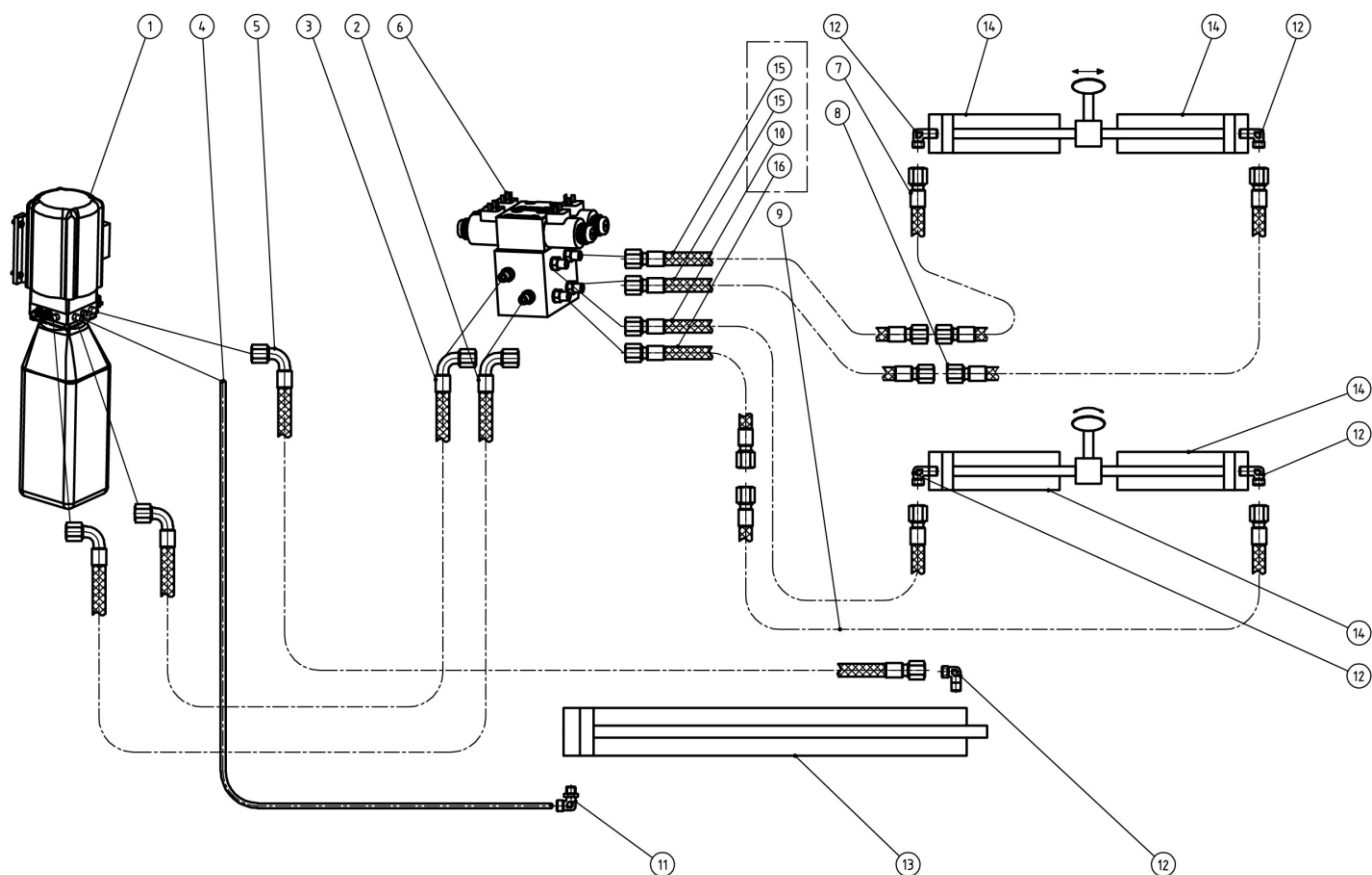
Hydraulic connections with PD

Pos.	CODE	Name	Specification	Qty	Remark
1	610032452	Hydraulic power unit	400V-3.0KW -3PH-50HZ	1	
2	624001190	Rubber oil hose	L=5800mm	1	57L/52L/48L
3	624002031	Oil back hose for PD	L=5800mm	1	57L/52L/48L
4	123010201	Oil drain hose for cylinder of the lift	D=8, L=4600mm	1	57L
		Oil drain hose for cylinder of the lift	D=8, L=4000mm	1	52L
		Oil drain hose for cylinder of the lift	D=8, L=3600mm	1	48L
5	624001194	Rubber oil hose	L=6300mm	1	57L
	624001195	Rubber oil hose	L=5700mm	1	52L
	624001254	Rubber oil hose	L=5300mm	1	48L
6	330101016	PD hydraulic block	6605-A-2	1	
7	624001193	Rubber oil hose	L=1850mm	1	57L/52L/48L
8	624001193	Rubber oil hose	L=1850mm	1	57L/52L/48L
9	624001211	Rubber oil hose	L=3400mm	1	57L/52L/48L
10	624001191	Rubber oil hose	L=3760mm	1	57L/52L/48L
11	310102013	90 connector with swivel	08N-M14S	1	
12	615018001	Throttle valve	MR30-A24-B16	1	
13	615027005	Oil cylinder	5T-6435B-A3-B19	1	
14	615031003	PD oil cylinder	GEG-PD-A1-B6	1	

Pos.	CODE	Name	Specification	Qty
6	330101057	SVLE.PD-J hydraulic block	SVLE.PD-J	1
7	330308015	Oil supplementing valve	BCYF-C-13.5	1
8	330201015	Gear pump (for 3P motor)	CBK-F233-G	1
9	330308006	Solenoid unloading valve	DHF06-220H/DC24	1
10	330308008	Leveling valve	DHF06-228H/DC24	1
11	330302001	Single way valve	DYF-C	1
12	330304001	Over flow valve	EYF-C	1
13	207103019	Composite washer	M14	4
14	310101003	Straight connector	M14X1.5-G1/4/60	3
15	201103001	Hex flange screw	M5*25	4
16	202109064	Hex socket cylinder head screw	M6*30	4
17	330401005	Oil sucking tube	XYGN-L293	1
18	330403001	Oil filter	YG-C	1
19	330402001	Oil returning tube	YH-D	1
20	330404001	Coupling	YL-A	1

Hydraulic scheme without PD

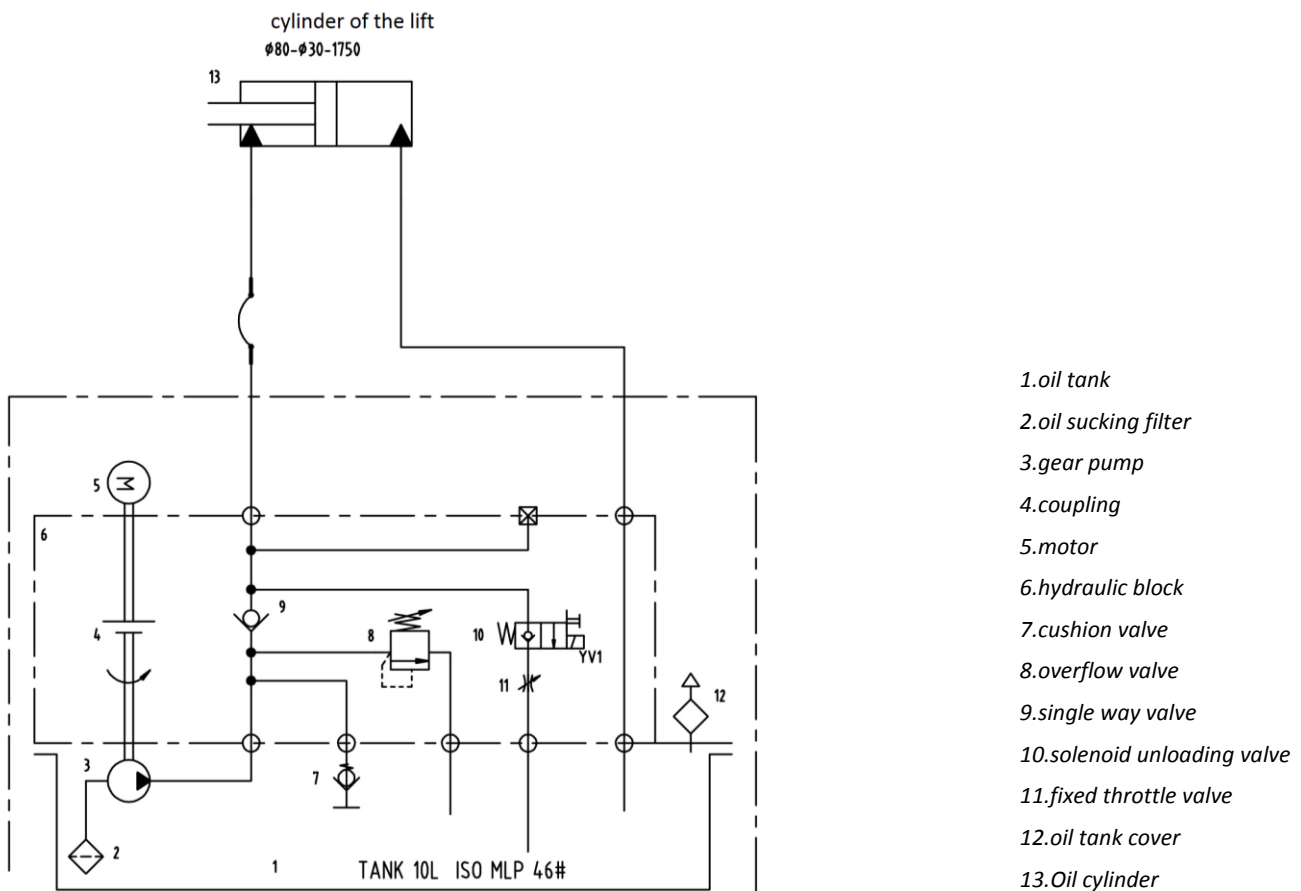

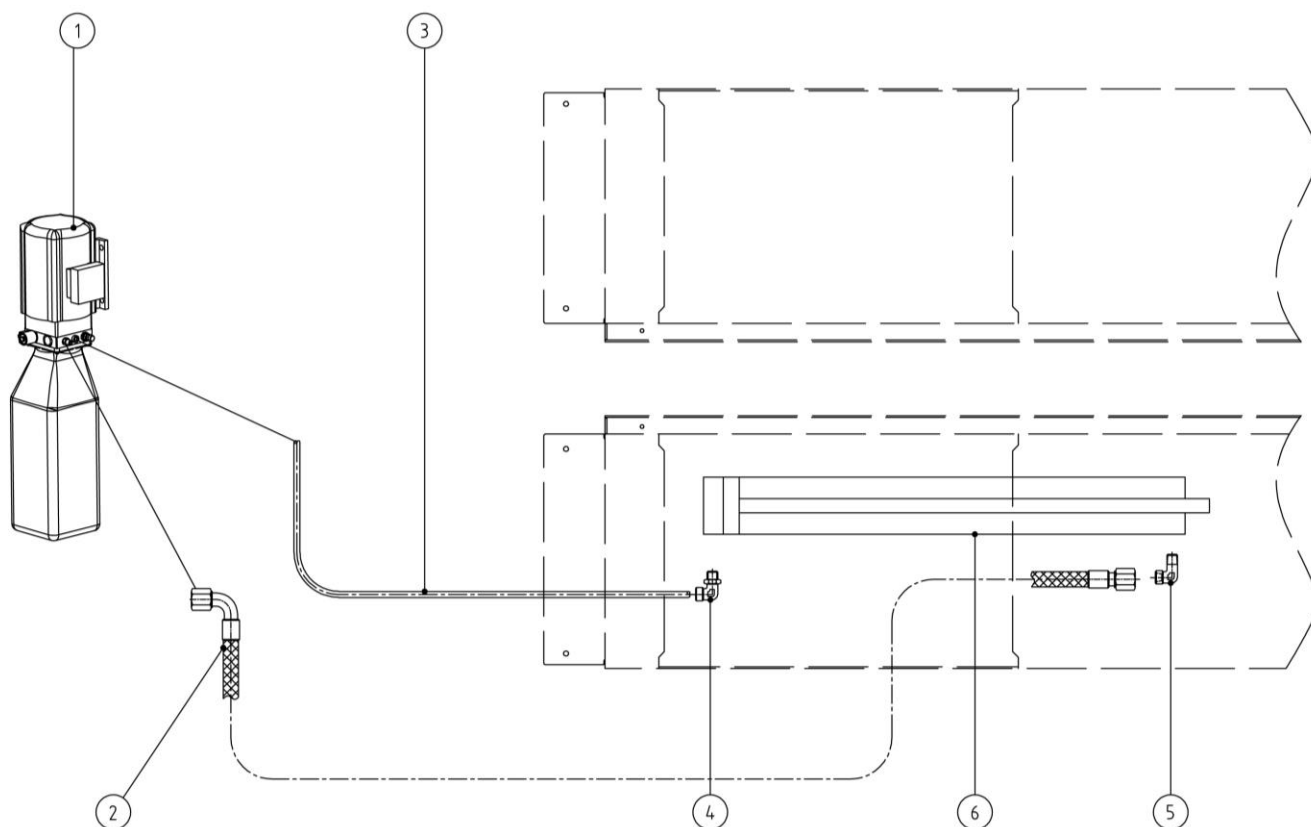
Hydraulic connections without PD

POS.	CODE	Name	Spec.	Qty	Remark
1		Power unit	3.0kW	1	NO PD
2	624001194	Rubber oil hose	L=6300mm	1	57L
	624001195	Rubber oil hose	L=5700mm	1	52L
	624001254	Rubber oil hose	L=5300mm	1	48L
3	123010201	Oil drain hose for cylinder of the lift	L=4600mm	1	57L
		Oil drain hose for cylinder of the lift	L=4000mm	1	52L
		Oil drain hose for cylinder of the lift	L=3600mm	1	48L
4	310102013	90 connector with swivel	08N-M14S	1	
5	615018001	Right angle throttle valve	MR30-A24-B16	1	
6	615027005	Oil cylinder	5T-6435-A3-B19	1	

POS.	CODE	Name	Spec.	Qty
7	330308006	Solenoid unloading valve	DHF06-220H/DC24	1
8	330302001	Single way valve	DYF-C	1
9	330304001	Over flow valve	EYF-C	1
10	310101028	Shifting connector	G1/4M14x1.5	1
11	330301001	Cushion valve	HZYF-C1	1
12	207103019	Composite washer	M14	1
13	210101003	Hex socket fitting	M14X1.5	1
14	201103001	Hex flange screw	M5*25	4
15	202109064	Hex socket cylinder head screw	M6*30	4
16	330401005	Oil sucking tube	XYGN-L293nylon 66, L=293mm	1
17	330403001	Oil filter	YG-C	1
18	330402001	Oil returning tube	YH-D	1
19	330404001	Coupling	YL-A	1

SEAL RINGS

POS.	CODE	Name	Spec.	Qty	Remark
1	207102026	KR seal ring	KR 80*64.5*6.3	1	Cylinder for the lift
2	207102024	Y seal ring	UP 70*80*8	1	Cylinder for the lift
3	207102025	Y seal ring	T601-30X40X8	1	Cylinder for the lift
4	207105010	Dust proof ring	A1-30*38*7	1	Cylinder for the lift
1	207102017	Y seal ring	17*25*6	1	Cylinder for PD
2	207106013	Guiding ring	25*2.5*5.5	1	Cylinder for PD
3	207106001	Guiding ring	20*2.5*15	1	Cylinder for PD
4	207105015	Dust proof ring	20*28*4.5	1	Cylinder for PD

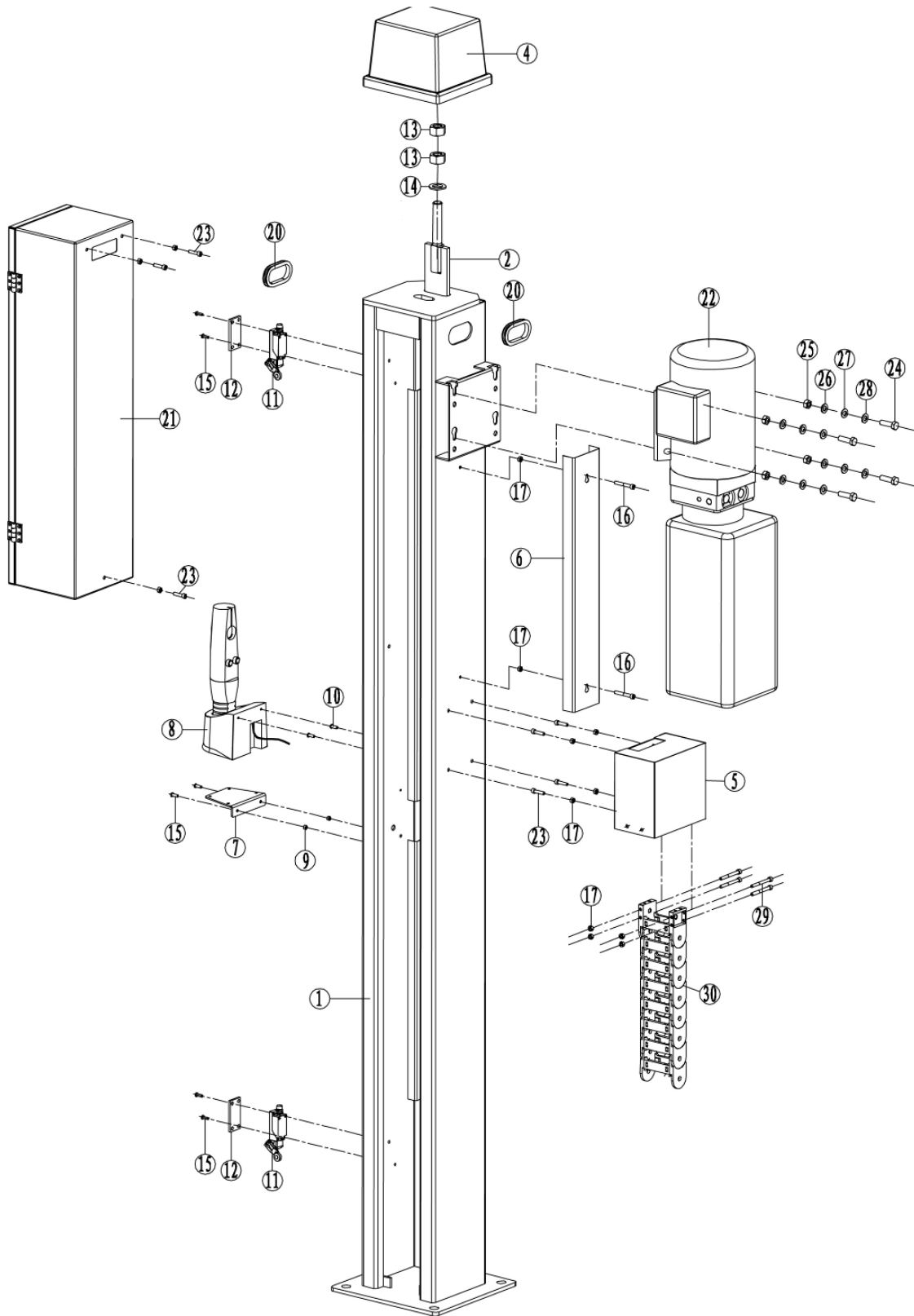
Annex 4, Mechanical exploded drawings and parts list

POS.	CODE	Name	Qty	NOTE
1	614027237D	Power side post	1	
	614027238C	Post	3	
2	612027009	Safety ladder	4	
4	420270200	Post cap	8	
5	614027250	Tank chain fixer A	1	
6	410273993	Oil hose cover	1	
7	410274353	PD charger holder	1	for model with PD
8	321201006	LED torch	1	for model with PD
9	203101003	Hex nut	2	M5
10	202101009	Cross socket cap head screw	2	M4*14
11	320301009	Limit switch	2	TZ-8104
12	410270221	Padding plate for limit switch	2	6435-A23
13	203101012	Hex nut	8	M20
14	204101011	Flat washer	4	M20
15	202110009	Hex socket button head screw	6	M5*16
16	202109024	Hex socket cylinder head screw	2	M6*35
17	203101004	Hex nut	13	M6
20	420250050B	Ring sheath for hose	2	
21		Control box	1	
22		Power unit	1	
23	202109022	Hex socket cylinder head screw	7	M6*25
24	201102020	Hex head full swivel screw	4	M10*35
25	203101006	Hex nut	4	M10
26	204101006	Flat washer	4	M10
27	204201005	Spring washer	4	M10
28	420040010	Anti-shock washer	4	
29	202109026	Hex socket cylinder head screw	4	M6*60
30	208101007	Plastic tank chain	1	L=1430mm
30	208101007	Plastic tank chain	1	L=1430mm

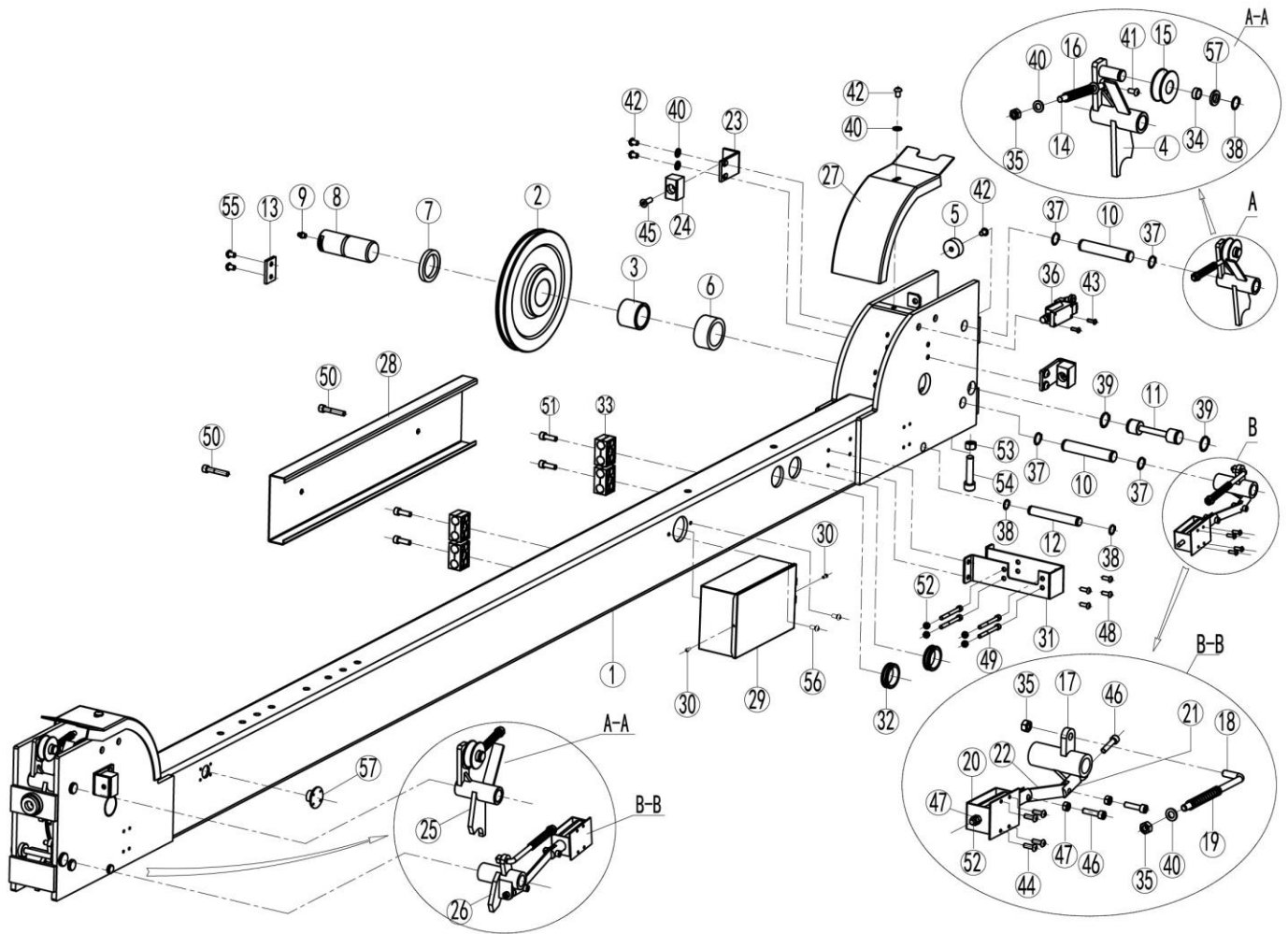

POS.	CODE	Name	Qty	NOTE
1	614027240D	Power side crossbeam	1	
	614027241D	The secondary crossbeam	1	
2	410274120	Pulley A	4	
3	205101070	Bushing	4	40*50*40
4	612027002	Safety block A1	2	
5	420270020	Sliding block (side)	4	
6	420270050	Spacer A	4	
7	420270060	Spacer B	4	
8	410273431B	Pulley shaft A	4	
9	208106001	Straight pressed cup	4	M8*1
10	410273441	Shaft I	8	
11	410273451B	Shaft II	4	
12	410273461	Shaft III	4	
13	410270101B	Shaft retaining block	4	

POS.	CODE	Name	Qty	NOTE
14	612027003	Adjustable rod B	4	
15	410270031B	Small sheave	4	
16	410270630	Spring	4	
17	410270051D	Safety block B1	2	
18	410270061	Adjustable rod A	4	
19	410270660	Spring	4	
20	330310007	Electromagnet	4	
21	410270601	Adjustable column	4	
22	410270151	Adjustable chip	4	
23	410270011	Slider holder	8	
24	420270010	Slider	8	
25	612027004	Safety block A2	2	
26	410270121D	Safety block B2	2	
27	420270190	Protective cover	4	
28	410270133B	PD oil hose cover	1	for model with PD
29	610027017	Terminal box	2	125*160*80mm
30	202101009	Cross socket cap head screw	2	
31	614027301	Tank chain fixer B	1	
32	420270150	Hose fixing ring (∅ 40)	2	
33	420270070	Oil hose protective sheath	8	for model with PD
34	205101001	Bearing	4	1615
35	203103006	Hex tightening nut	6	M8
36	320301011	Limit switch	4	TZ-8108
37	204301007	Circlip	16	M20
38	204301005	Circlip	12	M16
39	204301009	Circlip	8	M25(23.2)
40	204101005	Washer	20	M8
41	202103012	Cross socket flat head screw	4	M6*16
42	202110004	Hex socket button head screw	24	M6*15
43	202109020	Hex socket flat head screw	8	M5*16
44	202110010	Hex socket button head screw	8	M4*16
45	202111007	Hex socket flat head screw	8	M8*20
46	202109022	Hex socket cylinder head screw	6	M6*25
47	203101004	Hex nut	12	M6
48	202109021	Hex socket cylinder head screw	4	M6*20
49	202109026	Hex socket cylinder head screw (full swivel)	4	M6*60
50	201102015	Hex head full swivel screw	2	M8*40 for model with PD
51	202109031	Hex socket cylinder head screw	4	M8*30 for model with PD

POS.	CODE	Name	Qty	NOTE
52	202111005	Hex socket flat head screw	8	M8*15
53	203101007	Hex nut	4	M12
54	202109087	Hex socket cylinder head screw (10.9)	4	M12*70

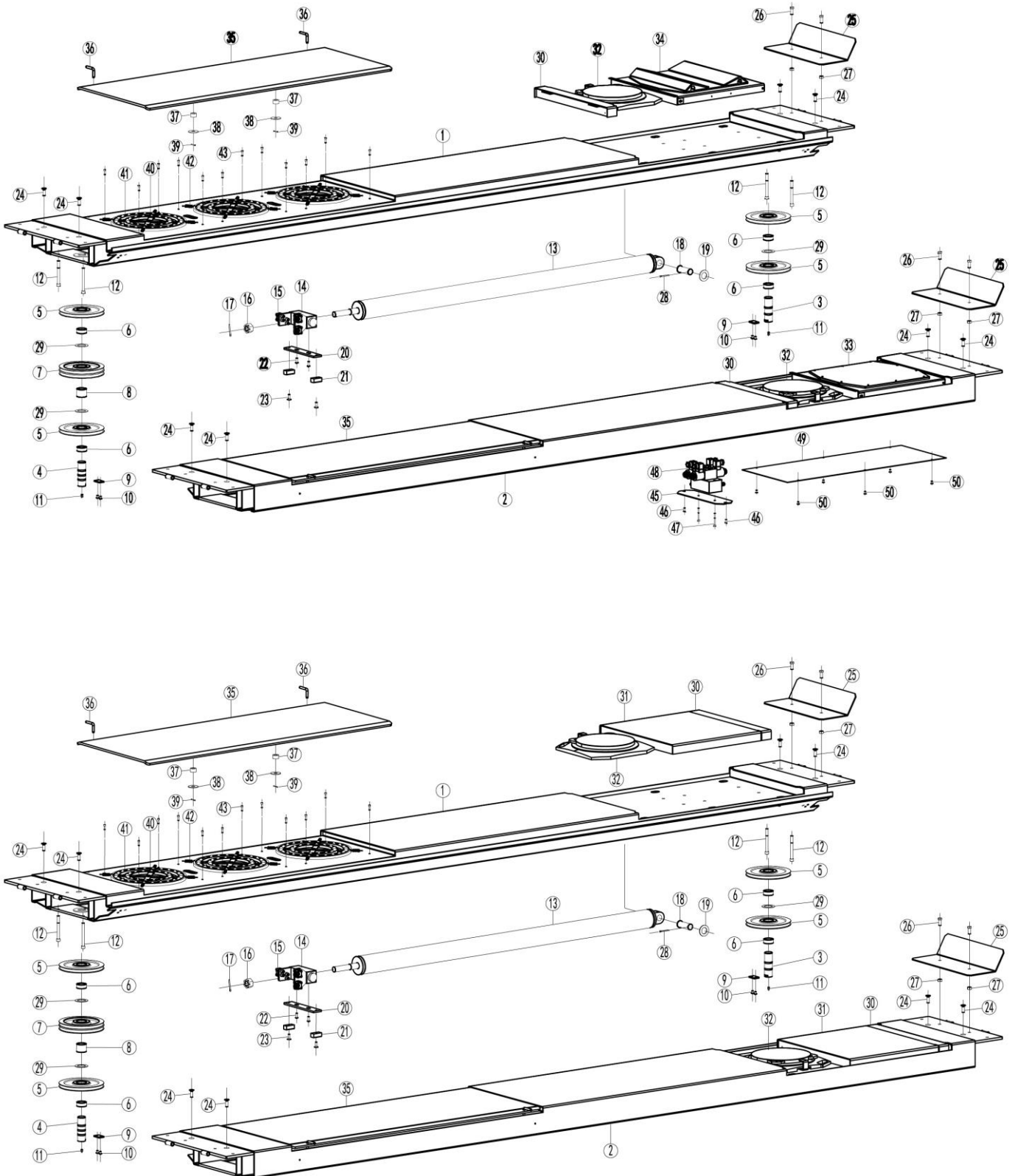

Pos.	CODE	Name	QTY	NOTE
1	614027246D	Platform A	1	57L.50T
1	614027256D	Platform A	1	52L.50T
1	614027316B	Platform A	1	48L.40T
2	614027247D	Platform B	1	57L.50T
2	614027257D	Platform B	1	52L.50T
2	614027317B	Platform B	1	48L.40T
3	410273801B	Pulley shaft B	1	
4	410273811B	Pulley shaft C	1	
5	410274133	Pulley B	4	
6	205101069B	Bushing	4	
7	410274143	Pulley C	1	
8	205101070	Bushing	1	
9	410270101B	Retaining block of the shaft	2	
10	202110004	Hex socket button head screw	4	M8*12
11	208106001	Straight pressed oil cup	2	
12	202109076	Hex socket cylinder head screw	4	M12*160
13	615027005	5T oil cylinder	1	
14	614027033B	Steel cable connection block	1	
15	208010001	Steel cable clip	4	
16		Open slot nut	1	M27*2
17		Cotter pin	1	φ5*50
18	410270281	Cylinder shaft II	1	
19	204101015	Flat washer	1	φ30
20	410274523B	Guiding plate	1	
21	420270240	Slider	2	
22	202110005	Hex socket button head screw	3	M8*20
23	202111007	Hex socket flat head screw	2	M8*20
24	202111015	Hex socket flat head screw	8	M12*25
25	410274513	Front wheel retaining plate	2	
26	201102027	Hex head full swivel screw	4	M12*30
27	203101007	Hex nut	4	M12
28	206201011	Cotter pin	1	M4*50
29	410278751	φ40 flat washer	3	φ40
30	614027320B	Portable box (70mm)	2	70mm
31	614027322B	Box	2	for model without PD
32	615027049	Turntable	2	
33	615031006B	PD A	1	for model with PD
34	615031007B	PD B	1	for model with PD

Pos.	CODE	Name	QTY	NOTE
35	614027248	Side slip plate	2	57L
35	614027258	Side slip plate	2	52L
35	614027318	Side slip plate	2	48L
36	410250221B	Bolt	4	
37	420210030	Nylon sheath	4	
38	410250011	Washer	8	
39	206201007	Cotter pin	4	
40	420270100B	Ball holder	6	
41	420270110B	Rotor ball	240	
42	410274470C	Pull spring	24	
43	202109020	Hex socket cylinder head screw M8*15	24	M8*15
44	203101004	Hex nut M6	24	M6
45	410274493	Installation plate for solenoid valve	1	for model with PD
46	201102008	Hex head full swivel screw M12*30	1	M6*16 for model with PD
47	202109026	Hydraulic block	1	M6*60 for model with PD
48		Hydraulic block assembly	1	for model with PD
49	410270243	Downside seal plate of the platform	1	for model with PD
50	202110003	Hex socket button head screw M6*12	6	M6*12 for model with PD