

EE-6435BWF

Four Post Lift

Electrical Release

With auxiliary lift for wheel free service

Lifting capacity: 4000KG/5000KG

Installation, Operation and Parts Manual



EAE

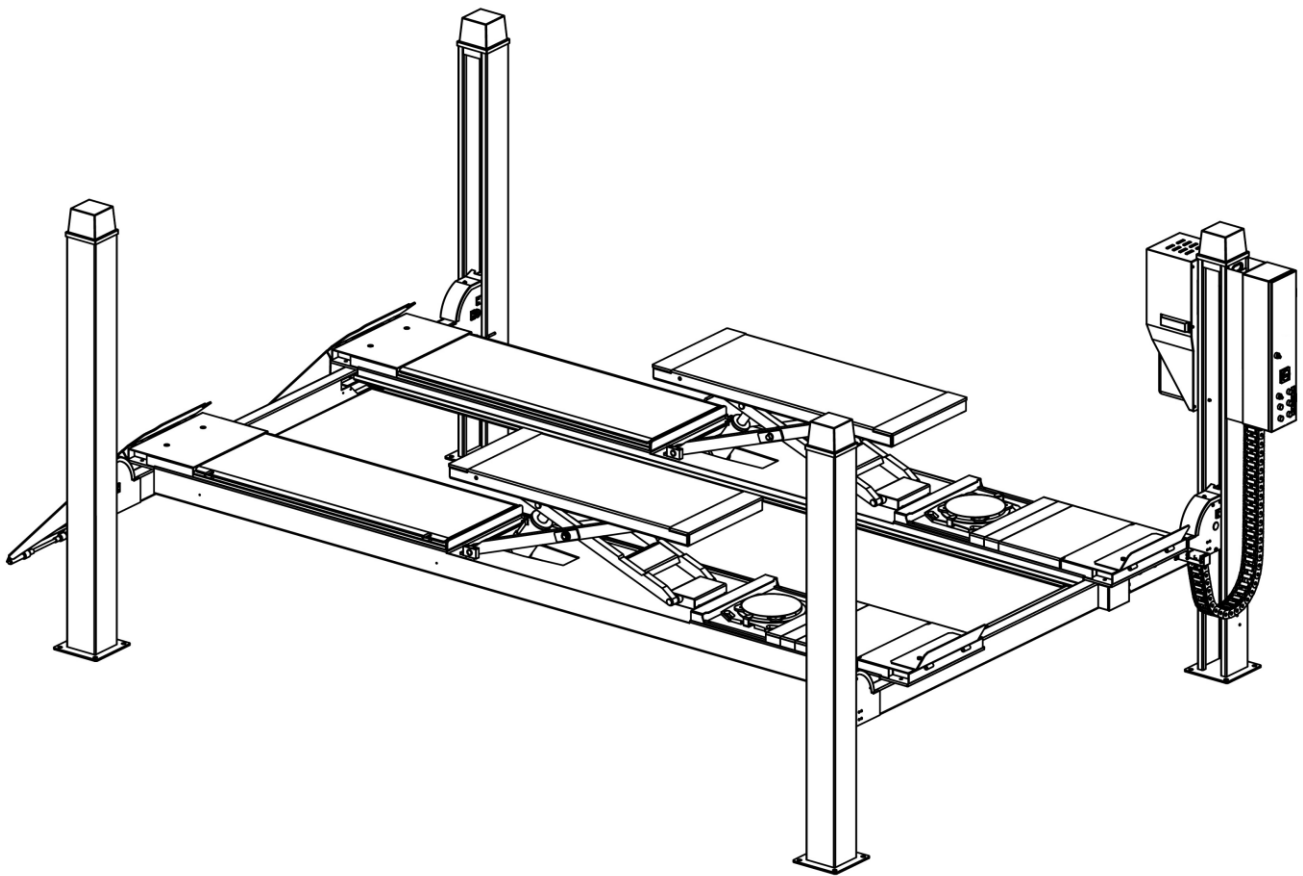

Distributed by

Please read this entire manual carefully and completely before installation or operation of the lift.

05/07/2023

www.eae-ae.com

IMPORTANT NOTES

Before start up, connecting and operating EAE products, it is absolutely essential that the operating instructions/owner's manual and, in particular the safety instructions are studied carefully. By doing so you can eliminate any uncertainties in handling EAE products and thus associated safety risks up front; something which is in the interest of you own safety and will ultimately help avoid damage to the device, When an EAE product is handed over to another person, not only the operating instructions but also the safety instructions and information on its designated use must be handed over to the person.

By using the product you agree the following conditions:

Copy right

The enclosed instructions are the property of EAE or its supplier, and are protected against duplication and reproduction by copyright laws, international agreements, and other domestic legislation. The reproduction or disclosure of instructions or an extract thereof is prohibited and offenders are liable to prosecution; EAE reserves the right or initiates criminal proceedings and asserts claims for damages in the event of infringements.

Warranty

The use of non-approved hardware will result in a modification of our products and thus to the exclusion of any liability or warranty, even if such hardware has been removed again in the interim.

It is not permissible to make any changes to our products and these are not only to be used together with genuine accessories and genuine replacement parts. Otherwise any warranty claims will be invalid.

Liability

The liability of EAE is limit to the amount that the customer has actually paid for this product. This exclusion of liability does not apply to damages caused through willful misconduct or gross negligence on the part of EAE.

All information in this manual is believed to be correct at time of publication.

EAE reserves the right to amend and alter technical data and composition without prior notice.

Please confirm at time of ordering.

IMPORTANT NOTES	2
SAFETY NOTES	4
1.1 Operation of lifting platforms	4
1.2 Checking of the lifting platforms	4
1.3 Important safety notices	5
1.4 Safety duties.....	6
1.5 Potential risks and safety measures.....	7
1.6 Noise level	7
PACKING, STORAGE AND TRANSPORTATION	8
2.1 The lift was dismantled into the following 2 parts for transportation.....	8
2.2 Storage	8
2.3 Lifting and handling.....	8
PRODUCTS DESCRIPTIONS	9
3.1 General descriptions	9
3.2 Construction of the lift	9
3.3 Dimensions.....	10
3.4 Safety devices descriptions	11
3.5 Technical data	12
3.6 Nameplate.....	12
INSTALLATION INSTRUCTIONS	13
4.1 Preparations before installation	13
4.2 Installation attentions	16
4.3 General installation steps.....	16
4.4. Items to be checked after installation	26
OPERATION INSTRUCTIONS	26
5.1 Precautions	26
5.2 Descriptions of control panel	27
5.3 Operation instructions	27
5.4 Emergent lowering in case of no power supply	29
TROUBLE SHOOTING.....	30
MAINTENANCE	31
Annex 1, Steel cable connection	33
Annex 2, Electrical schemes and parts list	34
Annex 3, Hydraulic schemes and parts list.....	40
Annex 4,Exploded drawings and parts list	44

SAFETY NOTES

1.1 Operation of lifting platforms

This lift is specially designed for lifting motor vehicles. Users are not allowed to use it for any other purposes. The applicable national regulations, laws and directives must be observed.

Only users aged 18 or above who have been instructed on how to operate the lifting platform and have proven their ability to do so to the owner are to be entrusted with unsupervised operation of lifting platforms. The task of operating the lifting platforms must be granted in writing.

Before loading a vehicle onto the lifting platform, users should study the original operation instructions and familiarize themselves with the operating procedures in several trial runs.

Lift vehicle within the rated load. Don't attempt to raise vehicles with excessive weight.

1.2 Checking of the lifting platforms

Checks are to be based on the following directives and regulations:

- Basic principles for testing lifting platforms
- The basic safety requirements stipulated in the directive 2006/42/EC
- The applicable accident prevention regulations

The checks are to be organized by the user of the lifting platform. The user is responsible for appointing an expert or qualified person to perform checking. It must be ensure that the person chosen satisfies the requirements.

The user bears special responsibility if employees of the company are appointed as experts or qualified persons.

1.2.1 Scope of checking

Regular checking essentially involves performing a visual inspection and a functional test. This includes checking the condition of the components and equipment, checking that the safety systems are complete and functioning properly and that the inspection log book is completely filled in. The scope of exceptional checking depends on the nature and extent of any structural modification or repair work.

1.2.2 Regular checking

After initial commissioning, lifting platforms are to be checked by a qualified person at intervals of no longer than one year.

A qualified person is somebody with the training and experience required to possess sufficient knowledge of lifting platforms and who is sufficiently familiar with the pertinent national regulations, accident prevention regulations and generally acknowledged rules of engineering to be able to assess the safe operating condition of lifting platforms.

1.2.3 Exceptional checking

Lifting platforms with a lift height of more than 2 meters and lifting platforms intended for use with people standing under the load bearing elements of the load are to be checked by an expert prior or reuse following structural modifications and major repairs to load bearing components.

An expert is somebody with the training and experience required to possess specialist knowledge of lifting platforms and who is sufficiently familiar with the pertinent national work safety regulations, accident prevention regulations and generally acknowledged rules of engineering to be able to check and give an expert opinion on lifting platforms.

1.3 Important safety notices

- 1.3.1 Recommend for indoor use only. DO not expose the lift to rain, snow or excessive moisture.
- 1.3.2 Only use this lift on a surface that is stable, level and dry and not slippery, and capable of sustaining the load. Do not install the lift on any asphalt surface.
- 1.3.3 Read and understand all safety warnings before operating the lift.
- 1.3.4 Do not leave the controls while the lift is still in motion.
- 1.3.5 Keep hands and feet away from any moving parts. Keep feet clear of the lift when lowering.
- 1.3.6 Only these properly trained personnel can operate the lift.
- 1.3.7 Do not wear unfit clothes such as large clothes with flounces, tires, etc, which could be caught by moving parts of the lift.
- 1.3.8 To prevent evitable incidents, surrounding areas of the lift must be tidy and with nothing unconcerned.
- 1.3.9 The lift is simply designed to lift the entire body of vehicles, with its maximum weight within the lifting capacity.
- 1.3.10 Always insure the safety locks are engaged before any attempt to work near or under the vehicle. Never remove safety related components from the lift. Do not use if safety related components are damaged or missing.
- 1.3.11 Do not rock the vehicle while on the lift or remove any heavy component from vehicle that may cause excessive weight shift.
- 1.3.12 Check at any time the parts of the lift to ensure the agility of moving parts and the performance of synchronization. Ensure regular maintenance and if anything abnormal occurs, stop using the lift immediately and contact our dealers for help.
- 1.3.13 Lower the lift to its lowest position and do remember to cut off the power source when service finishes.
- 1.3.14 Do not modify any parts of the lift without manufacturer's advice.
- 1.3.15 If the lift is going to be left unused for a long time, users are required to:
 - a. Disconnect the power;
 - b. Empty the oil tank;
 - c. Lubricate the moving parts with hydraulic oil.

WARNING: The warnings, cautions and instructions discussed in this instruction manual cannot cover all possible conditions and situations that may occur. It must be understood by the operator that common sense and caution are factors which cannot be built into this product, but must be supplied by the operator.

Attention: For environment protection, please dispose the disused oil in a proper way.

1.4 Safety duties

All safety warning labels are clearly depicted on the lift to ensure that the operator is aware of and avoid the dangers of using the lift in an incorrect manner. The labels must be kept clean and they have to be replaced if detached or damaged. Please read carefully the meaning of each label and memories them for future operation.

CAUTIONS

- Read and digest the complete operation instructions before operating the lift.
- This lift is designed to raise the entire body of the intended vehicles. Don't use it for other purposes.
- Inspect the space above and below the load and the loading carrying devices. It shall be free of obstructions before operating.
- Before raising operation, run the lift without load for a complete cycle to ensure it is in good condition.
- The supporting pads must be placed to pick-up points recommended by vehicle manufacturers. (Only for chassis supporting lift)
- Before lifting the vehicle and during all operations on the vehicle, make sure that it is properly stopped by the hand brake.
- Check the vehicle after raising a short distance to ensure that it is correctly and safely positioned.
- The load carrying device shall be observed by the operator throughout the motion of the lift.
- Engage the safety locking mechanism before entering under the raised vehicle.

WARNINGS

- ONLY authorized persons are permitted in the lift area.
- Always remember to use safety stands before removing or installing heavy parts. (Only for chassis supporting lift)
- Avoid excessive rocking of vehicle while on the lift
- Do not climb onto the load or load carrying device when they are raised.

DANGERS

- It is forbidden for people to stand in the field of motion during raising or lowering movement.
- Do not try to raise the vehicle with excessive length or width. Otherwise there is risk of vehicle falling from lift.
- Do not try to remove, interrupt or modify the safety devices.
- Electrical connection and maintenance must be done by qualified electricians, otherwise there could be danger of electric shock.

The instructions, cautions and warnings written above as well as in the in Manual cannot cover all possible conditions and situations that may occur. The Common sense for safety must be always in the mind of the operator. For damages caused through willful misconduct or gross negligence, the lift manufacturer or its distributors are excluded of liability.

1.5 Potential risks and safety measures

1.5.1 RISK OF CRUSHING

Safety measures:

- During lift functioning, the operator must remain at the control station
- The presence of persons beneath the crossbeams and/or the platforms when they are moving, or the presence of persons inside the danger zone indicated in the following figure is strictly prohibited.
- During operations persons are admitted to the area beneath the vehicle only when the vehicle is already in the elevated position, when the crossbeams and platforms are stationary, and when the mechanical safety devices are engaged
- When the platforms (and vehicle) are lowering the operator must never be partly or completely underneath or near of the movable structure.
- The lift operator must not start the lift until it has been clearly established that there are no persons in danger zone.

1.5.2 RISK OF IMPACT

Caused by the parts of the lift or the vehicle that are positioned at head height.

Safety measure:

Personnel must be careful to avoid impact with parts of the machine not marked with special colors.

1.5.3 RISK OF VEHICLE MOVING

Caused by operations involving the application of force sufficient to displace the vehicle.

In the case of large or particularly heavy vehicles, sudden movement could create an unacceptable overload or uneven load sharing.

Safety measure:

Make sure that the vehicle is properly stopped by the hand brake before being raised.

1.5.4 RISK OF VEHICLE FALLING FROM LIFT

This hazard may arise in the case of incorrect positioning of the vehicle on the platforms, incorrect stopping of the vehicle, or in the case of vehicles of dimensions that are not compatible with the capacity of the lift.

Safety measure:

Check the vehicle after raising a short distance to ensure that it is correctly and safely positioned.

1.5.5 RISK OF SLACKENING OF LIFT CABLES

Caused by objects left leaning against the posts or on the platforms.

Safety measure:

Inspect the space above and below the load and the loading carrying devices. It shall be free of obstructions before operating.

1.5.6 RISK OF SLIPPING

Caused by lubricant contamination of the floor around the lift.

Safety measure:

The area beneath and surrounding the lift and also the platforms must be kept clean. Remove any oil spills immediately.

1.6 Noise level

Noise emitted during operating the lift should be less than 70dB (A). For your health consideration, it is suggested to place a noise detector in your working area.

PACKING, STORAGE AND TRANSPORTATION

Packing, lifting, handling, transporting operations must be performed only by experienced personnel with appropriate knowledge of the lift and after reading this manual.

2.1 The lift was dismantled into the following 2 parts for transportation

Name	Packed by	Dimension(mm)	Weight(kg)	Quantity
Lift (48L)	Steel brackets	4950*740*900	About 1550	1
Lift (52L)	Steel brackets	5350*740*900	About 1750	1
Lift (57L)	Steel brackets	5850*740*900	About 2000	1
Ramps	Bubbled film	1500*570*180	45	2

2.2 Storage

The packs must be kept in a covered and protected area in a temperature range of -10°C to $+40^{\circ}\text{C}$. They must not be exposed to direct sunlight, rain or water.

Stacking the packs

We advise against stacking because the packs are not designed for this type of storage. The narrow base, heavy weight and large size of the packs make stacking difficult and potentially dangerous.

If stacking is unavoidable, use all appropriate precautions:

-never stack to more than 2 meters in height.

-never make stacks of single packs. Always stack pairs of packs in a cross pattern so that the base is bigger and the resulting stack is more stable. Once the stack is complete, restrain it using straps, ropes or other suitable methods.

A maximum of two packs can be stacked on lorries, in containers, and in railway wagons, on condition that the packs are strapped together and restrained to stop them falling.

2.3 Lifting and handling

The packs can be lifted and transported only by using lift trucks.

The center of gravity and lashing points are marked on the packaging.

Never attempt to hoist or transport the unit using lifting slings.

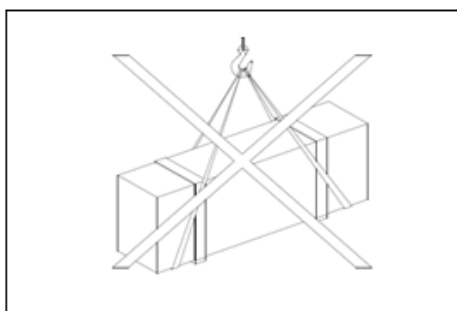
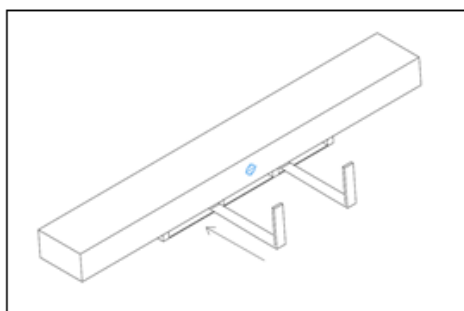

Opening the packs

When the lift is delivered make sure that it has not been damaged during transportation and that all the parts specified on the packing list are present.

Packs must be opened adopting all the precautions required to avoid injury to persons (keep at a safe distance when cutting the straps) or damage to parts of the machine (be careful that no parts are dropped while you are opening the packing)

Take special care with the hydraulic power unit, the control panel and the platform cylinder.

PRODUCTS DESCRIPTIONS

3.1 General descriptions

This four post lift is generally composed by four posts, two beams, two platforms, a hydraulic oil cylinder and a set of power unit. It is driven by an electro-hydraulic system. Up and down of platforms is controlled by the to and fro movement of the oil cylinder. To ensure safety for operators, it is equipped with mechanical safety locks in the four posts, which will automatically engaged in the process of lifting so as to prevent the platforms from sudden dropping down in case the hydraulic system fails to work.

3.2 Construction of the lift

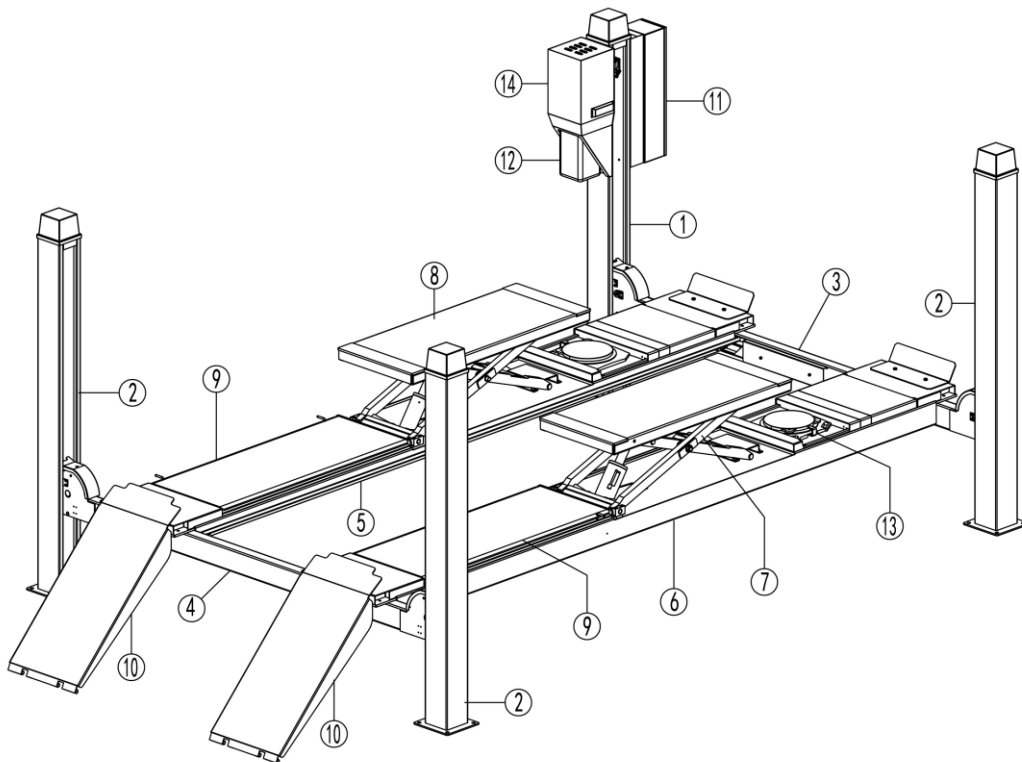

1. Power side post 2. Post 3. Power side crossbeam 4. The secondary crossbeam 5. Main platform
 6. The secondary platform 7. main platform of the wheel free lift 8. The secondary platform of the wheel free lift
 9. Side slip 10. Drive-on ramps 11. Control box 12. Power unit 13. Turntabl (optional) 14. Motor housing

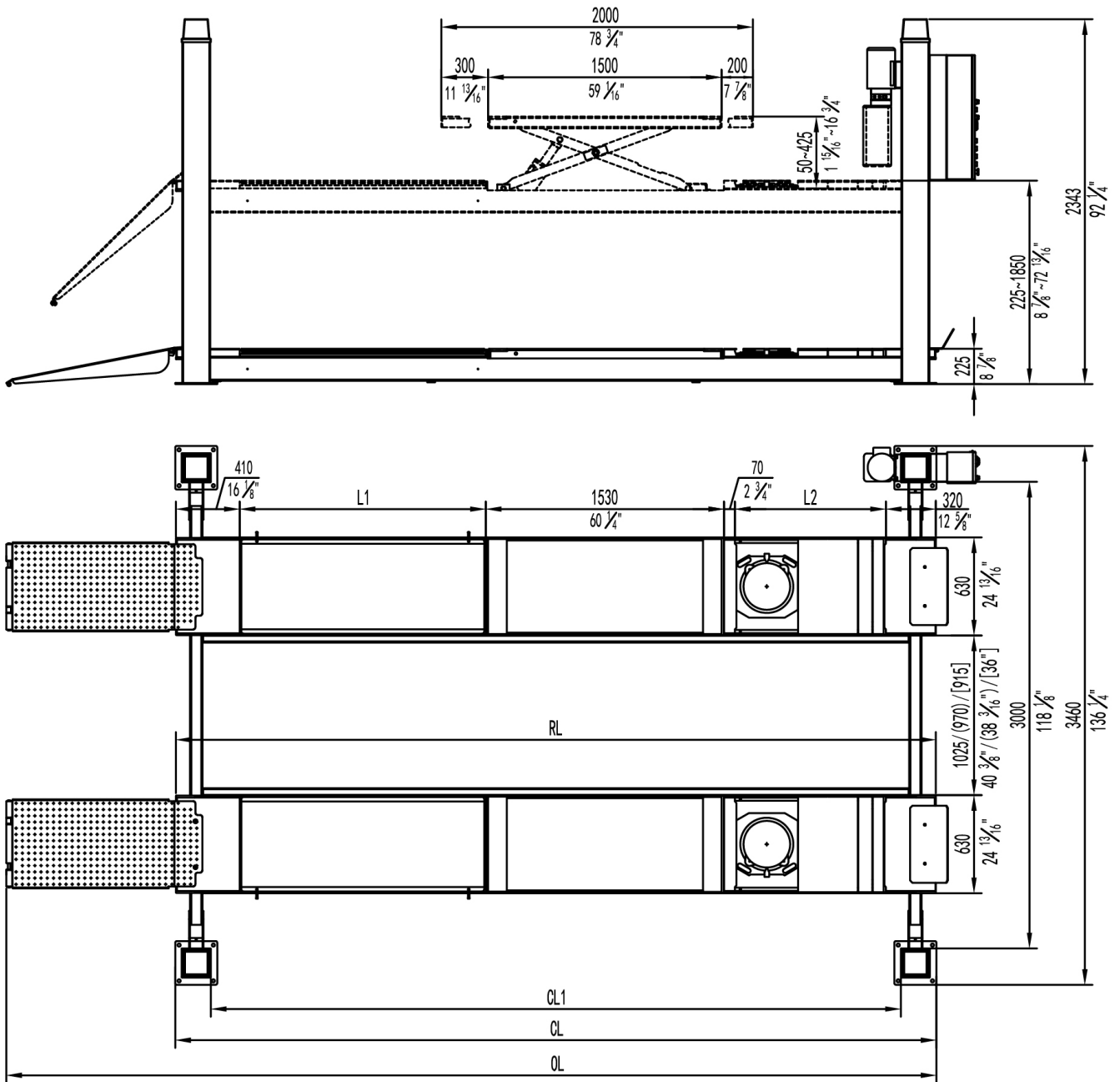
3.3 Dimensions

DATA	MODEL		
	48L	52L	57L
RL	4880 (192 1/8")	5280 (207 7/8")	5780 (227 9/16")
OL	5970 (235 1/16")	6370 (250 13/16")	6870 (270 1/2")
CL	4888 (192 7/16")	5288 (208 3/16")	5788 (227 7/8")
CL1	4438 (174 3/4")	4838 (190 1/2")	5338 (210 3/16")
L1	1580 (62 3/16")	1980 (77 15/16")	2280 (89 3/4")
L2	970 (38 1/8")	970 (38 1/8")	1170 (46")

3.4 Safety devices descriptions

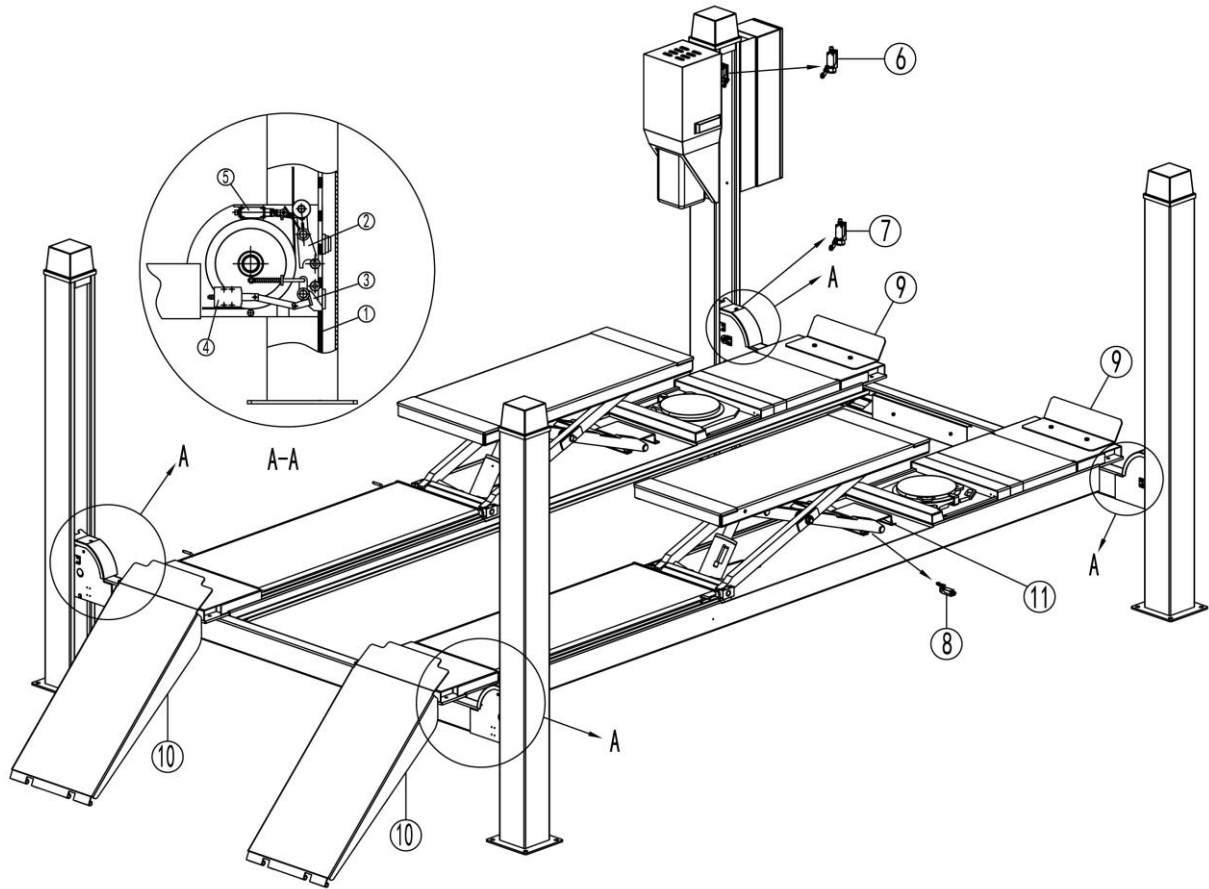

NO.	Safety Device	Function
1	Safety rod	Ensure mechanical safety in the rising and lowering process and lock the lifting platform at expected height.
2	Safety block A	
3	Safety block B	
4	Electromagnet	Release the mechanical locking unit.
5	Limit switch	Disconnect operation power in case of slacken steel cables.
6	Max height limit switch	Control max rising height and protect the oil cylinder.
7	Descent limit switch	Make the platform stop lowering at safety height so as to guard against pinching or shearing. Push the other button (DOWN II) to lower the runway completely.
8	Height limit switch of the wheel free lift	Control the rising height and protect the oil cylinder of the wheel free lift.
9	Front wheel retainer	Prevent the vehicle from rolling off.
10	Drive-on ramps	The wheel retainer functions when the platform is lifted.
11	Tip-off protection for the wheel free lift	Protect lifting platform from tipping-up, in case of unbalanced loading.

3.5 Technical data

Item	Data
Power Form	Electro-hydraulic
Rated capacity of the lifting platform	4000kg(48L/52L), 5000kg (48L/52L/57L)
Full rise height of the main lift	1850mm
Initial height of the main lift	225mm
Full rise time of the main lift	Approx.65s (2.2kW)
	Approx.45s(3.5kW)
Full lowering time of the main lift	30-40S
Rated capacity of the wheel free lift	4000kg
Rising height of the wheel free lift	450mm
Working pressure	Main lift $\geq 18\text{MPa}$; wheel free lift $\geq 21\text{MPa}$
Electricity	380V/400V/415V-3PH-50HZ or 60HZ
Motor	2.2 /3.0/3.5kW
Hydraulic oil	12L, 46# hydraulic oil
Noise	< 75dB(A)

3.6 Nameplate

The nameplate is fixed beneath the oil tank

Check the work voltage and the lift capacity printed on the name plate.

Do not lift vehicles with weight beyond the capacity.

S/N and production date could be helpful for future service.

INSTALLATION INSTRUCTIONS

4.1 Preparations before installation

4.1.1 Space requirements.

Refer to 3.3 for the dimensions of the lift. There must also be a clearance of at least 0.6 meter between the lifting platform and fixed elements (e.g. wall) in all lifting positions. There must be sufficient space at the ends of the lifting platform for driving vehicles on and off.

To stop vehicles colliding with the ceiling, it is advisable to fit an overhead light barrier in low ceiling buildings.

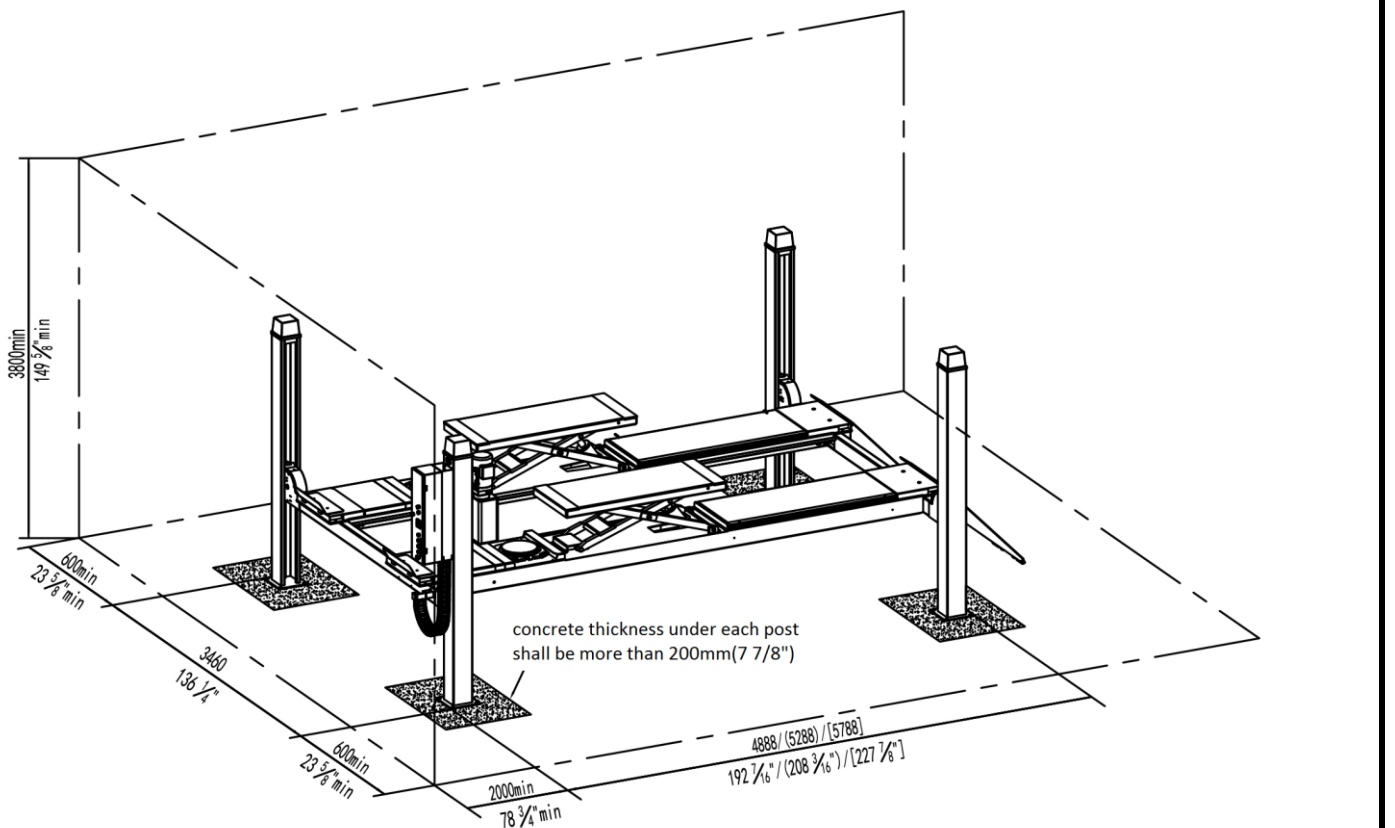

4.1.2 Foundations and connections

The user must have the following work performed before erecting the lift.

- Construction of the foundation following consultation with the manufacturer's customer service or an authorized service agent.
- Routing of the wiring to the installation location. **The user must provide fuse protection for the connection. Electrical system connection must be done by qualified electricians.** Requirements for power supply cable of the installation site: at least 2.5mm² wire core for 3Ph power and 4.0mm² wire core for 1Ph power.
- Foundations preparations

Indoor installation only.

There must also be a clearance of at least 0.6 meter between the lifting platform and fixed elements (e.g. wall) in all lifting positions.

There must be sufficient space for driving vehicles on and off.

C20/25 concrete foundation with a minimum thickness of 200mm.

Surface under the base of post: Horizontal and even (Gradients max. 0.5 %)

Newly built concrete ground must be older than 20days.

In mm.

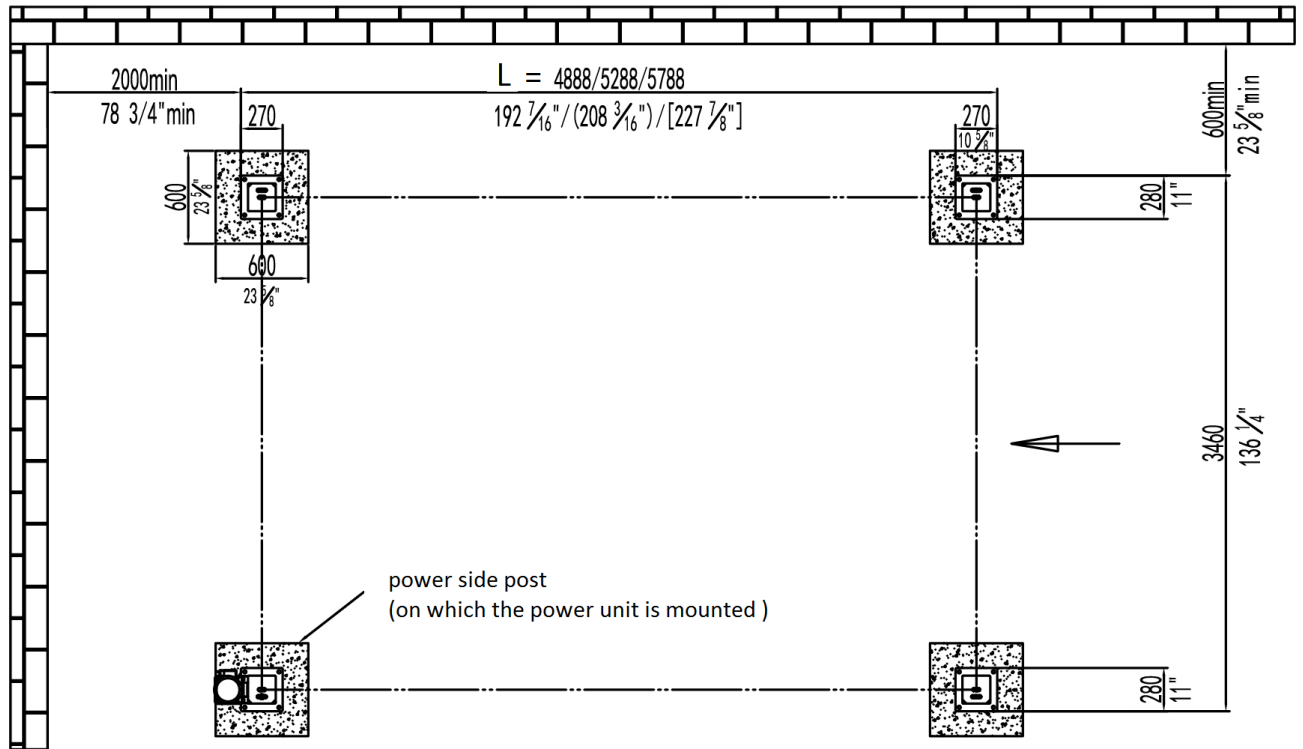
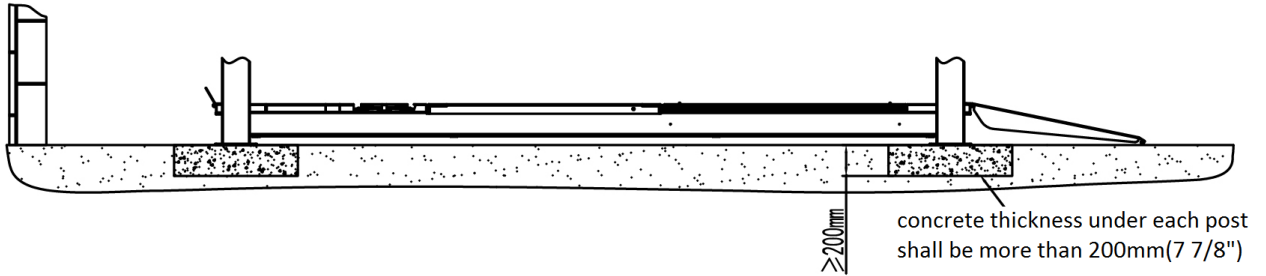

Platform length	L
48L	4888 (192 7/16")
52L	5288(208 3/16")
57L	5788(227 7/8")

4.1.3 Tools and equipment needed for installation

Tool name	Specification	Quantity
Electrical driller		1
Drill bit	D18 and D20 (L=350mm)	1
Open end spanner	D17-19	2
Open end spanner	D22—24	1
Adjustable wrench	>D30	1
Hex socket spanner kits	M3 to M10	1
Torque spanner	MD400	1
Spline end spanner kits	D24—27	1
Phillips screwdriver	PH2	1
Flat Tip screwdrivers	PH2	1
Knife		1
Plumb	this is for levelling	1
Crowbar	40cm	1
Needle Nose Pliers		1
Hammer	4 pounds/10 pounds	1
Circlip Pliers		1

4.1.5 Checking parts

Unfold the package and check if any parts missed as per the following list. Do not hesitate to contact us in case any parts missed, but if you do not contact us and insist installing upon the lack of some parts, we as well as our dealers will not bear any responsibility for this and will charge for any parts subsequently demanded by the buyer.

S/N	Name	Qty
1	Platform A	1
2	Platform B	1
3	Power side post	1
4	Post	3
5	Power side crossbeam	1
6	The opposite crossbeam	1
7	Front wheel retainer	2
8	Power unit	1
9	Control unit	1
10	Slider	8
11	Slider holder	8
12	Protective cover	4
13	Post cap	4
14	Ramp shaft	2
15	Expansion bolt M16*120	16

S/N	Name	Qty
16	Hex head full swivel screw M12*30	4
17	Hex socket flat head screw M12*80	8
18	Hex head full swivel screw M10*35	4
19	Hex socket button head screw M8*16	20
20	Spring washer $\varnothing 10$	4
21	Hex nut M10	4
22	Hex nut M12	4
23	Hex nut M20	12
24	Cotter pin 2.5*30	4
25	Flat washer $\varnothing 10$	4
26	Flat washer $\varnothing 8$	20
27	Anti-shock pad	4
28	Cross socket cap head screw M4*14	2
29	Manual	1
30	Drive-on ramp	2

4.2 Installation attentions

- 4.2.1 Joints of oil hose and wiring must be firmly connected in order to avoid leakage of oil hose and looseness of electrical wires.
- 4.2.2 All bolts should be firmly screwed up.
- 4.2.3 Do not place any vehicle on the lift in the case of trial running.

4.3 General installation steps

ONLY TRAINED AND QUALIFIED INSTALLERS CAN PERFORM LIFT INSTALLATION DUTIES.

Step 1: Ascertain the layout dimensions.

Mark the four positions for base plate of the four posts by a tape measure and chalk.
 Ensure two diagonal lines are of the same length.

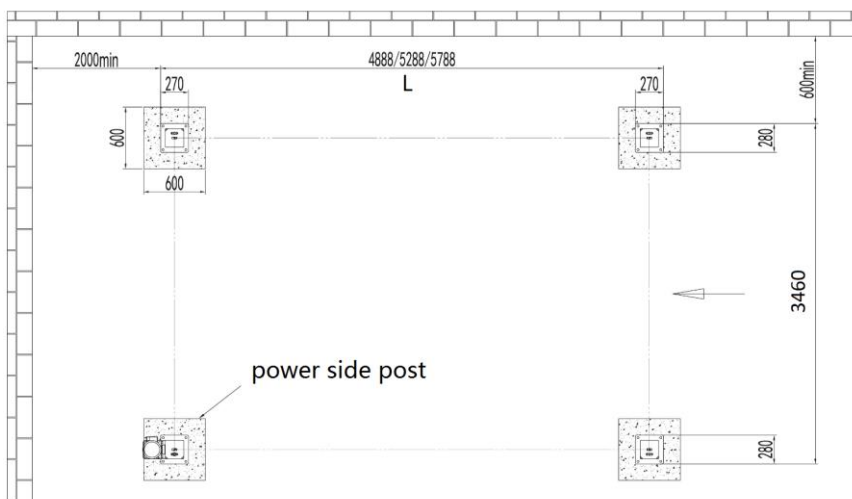

Step 2: Remove the packing materials.

1. Prepare 4 wooden battens with thickness being more than 100mm and length being more than 700mm. (other dependable devices may also applicable). Forklift the packing rack onto two of the battens so as to make its base be clear off the ground.

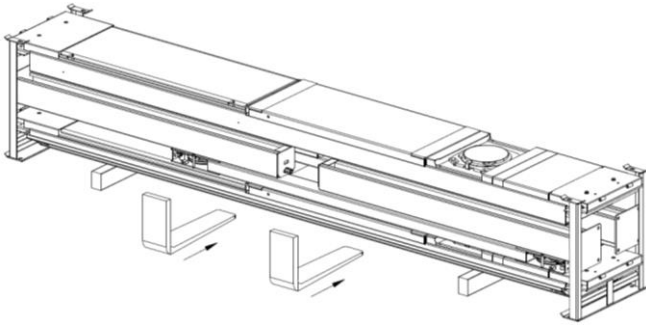

2. Have the upper platform suspended by the forklift, screw off the corresponding bolts that fixed with the packing racket and remove the upper platform onto the rest two battens.

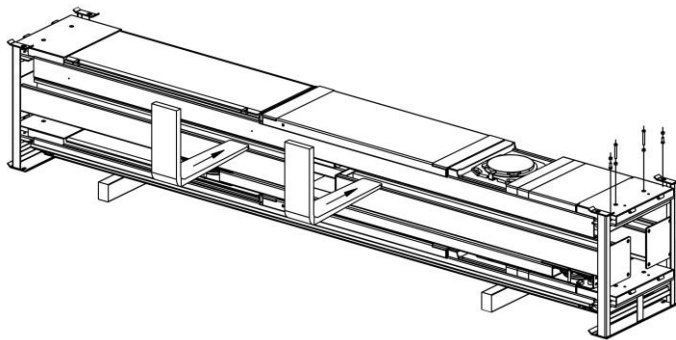

3. Screw off the under bolts and take away the packing racks at both sides.

4. Remove the packing film.

Attention: Take care and avoid scratching the painting and hoses.

Step 3: Position four posts and two crossbeams.

Place four posts to standing positions as per the layout dimensions.

Put parts like control unit, power unit, tank chain, post caps and protective covers aside.

Move the rest two crossbeams in the direction of the arrows indicated in the following scheme.

CAUTION: Make sure to read and understand before trying to remove the crossbeams. Otherwise, there is a risk of damaging the steel ropes.

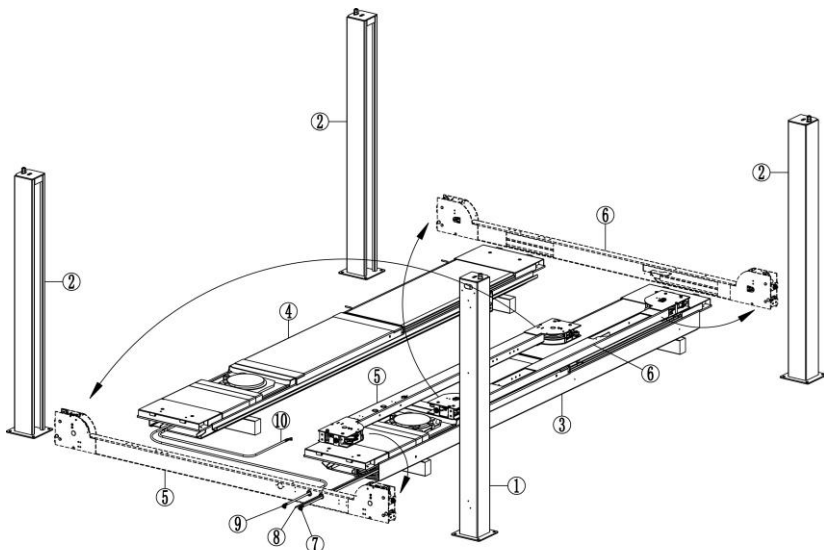

1. Power side post
2. Post
3. Main platform
4. Secondary platform
5. Main crossbeam
6. Secondary crossbeam
7. Oil-supply hose for the main lift
8. Oil-return hose
9. Oil-supply hose for the master cylinder of the wheel free lift
10. Oil-supply hose for the slave cylinder of the wheel free lift

Pull oil hoses No.7 and No.8 from the main platform and make them go through the right side hole reserved at the crossbeam.

(The hose No.7 has a right-angled fitting.)

Pull hoses No.9 and NO.10 from the secondary platform and make oil hose NO.9 go through the left side hole reserved at the crossbeam.

(The hose No.9 has a right-angled fitting. The hose No. 10 has an angled fitting with 45 degree.)

Step 4: Assemble crossbeams onto both ends of the platforms.

1. Align the two platforms at both ends and keep a distance about 1025mm between them (excluding the width of the two tracks for rolling jacks)
2. Connect the crossbeam and the lifting platform using hex socket flat head screws (M12*80). Tighten all the screws only after two crossbeams are well fit with the two platforms. Use proper lifting device to move the corresponding platform, in the case the screw holes are not well aligned.

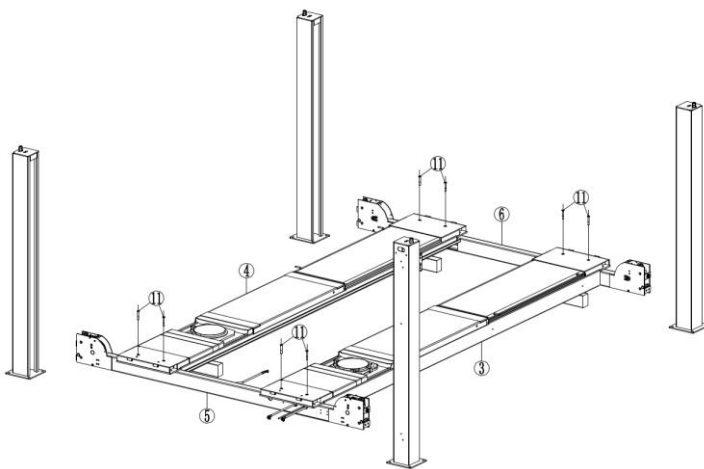

3.Main platform

4.Secondary platform

5.Main crossbeam

6.Secodnary platform

11.M12*80 Hex socket flat head screw

Step 5: Install posts and ratchets of the mechanical locking device.

1. Pull the safety ratchet (NO.12) through the hole on the top of the post until the other end of the ratchet is above the end of crossbeam. (Use proper devices to keep the four ratchets stay above the ends of crossbeam as indicated in the following fig.)

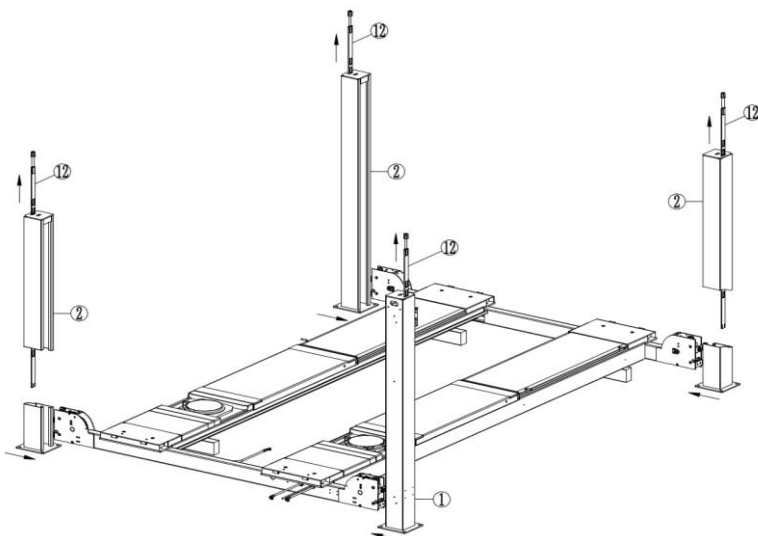

1.Powerside post

2.Post

12.Safety ratchet

2. Push the power side post to the direction of the crossbeam and insert the ratchet down through the inner surface of the end plates of the crossbeam. (Take special care not to damage the limit switch NO.13 in the following fig.)

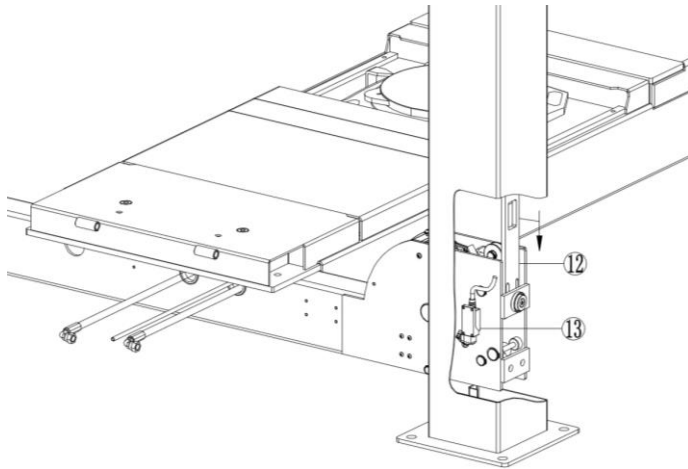

12. Safety ratchet

13. Limit switch (for safe descent)

Step 6: Route and fix steel ropes.

Please see Annex 1 for steel cable routing.

Inspect and make the rope be in the slot of the two pulleys (NO.15 and NO.16 in the following fig.)

Pull the rope (NO.14) up through the hole reserved on top of the post and fix it with screws.

(Attention: Fix with two M20 nuts (NO.17) and one ϕ 20 flat washer (NO.18) above the top plate.

Fix with one M20 nut and one ϕ 20 flat washer under the top plate.)

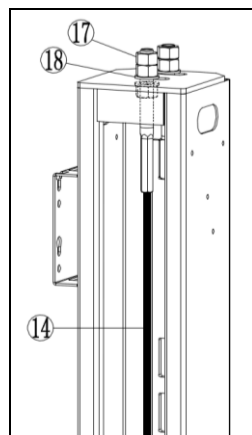
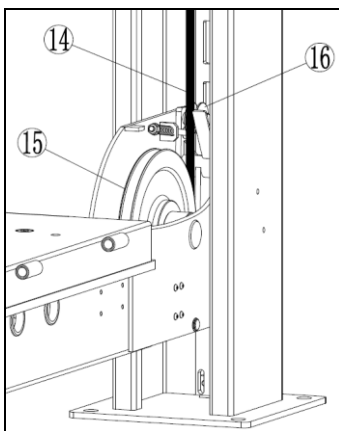

14. steel rope

15. pulley A

16. small pulley

17. M20 nut

18. ϕ 20 flat washer

Step 7: Install holders for sliding blocks, fix protective covers and fix the other end of the safety ratchets.

1. Make the holder (NO.19) for sliding block be hooked with folded edge of the post and fix it with the crossbeam using M8*12 hex socket button head screw (NO.20).
2. Fix the protective cover (NO.22) with the crossbeam using M8*12 hex socket button head screw (NO.20).
3. Fix the other end of the safety ratchet at bottom of the post using M8*20 hex socket button head screw (NO.23)

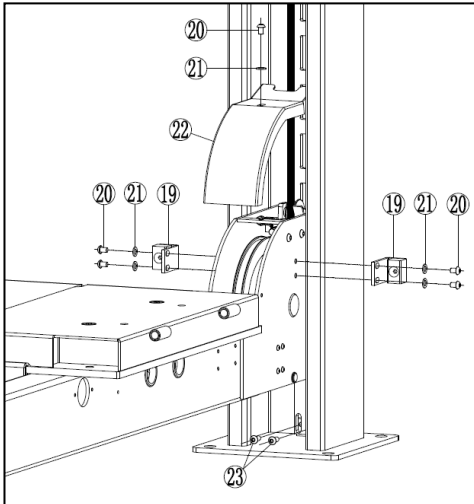

19. Holder for sliding block (including sliding block)
 20. Hex socket button head screw M8*12
 21. Flat washer $\phi 8$
 22. Protective cover
 23. Hex socket button head screw M8*20

Step 8: Install control and power unit.

1. Firstly, fix the control unit (NO.24) with its installation kit (NO.25) using M6*15 hex socket cylinder head screw (NO.26) and M6 nut (NO.27).

After that install the control unit onto the power side post using M6*15 hex socket cylinder head screw (NO.26) and M6 nut (NO.27).

2. Fix the plate for hanging power unit (NO.28) onto the side opposite to the control unit and fix the power unit onto the hanging plate as indicated in the following fig.

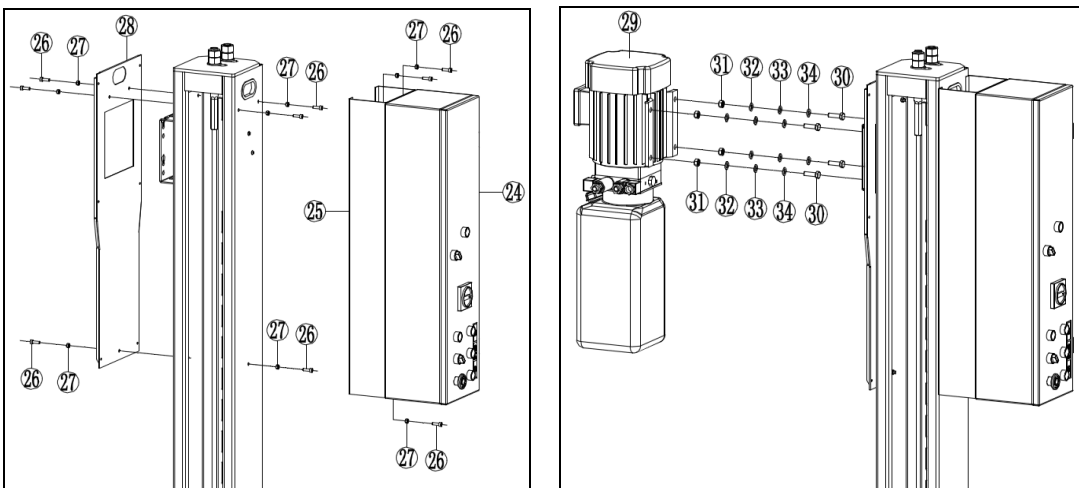

24. Control unit
 25. Installation kit for control unit
 26. M6*15 hex socket cylinder head screw
 27. M6 nut
 28. Plate for hanging power unit
 29. power unit
 30. M10*35 hex head screw
 31. M10 hex nut
 32. $\phi 10$ spring washer
 33. $\phi 10$ flat washer
 34. Anti-shock pad

Step 9, Install the CHAIN Protection and connect electrical and hydraulic system

1. Arrange hoses and wires neatly and make them go through the CHAIN protection (NO.36) one by one. Fix one end the CHAIN onto the crossbeam and the other end onto the installation kit for control unit.

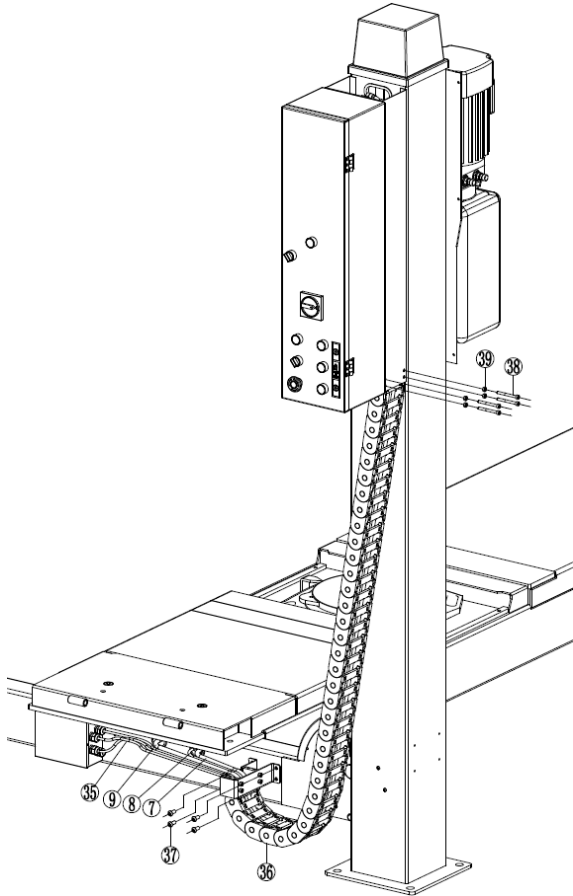

- 7. Oil-supply hose for the main lift
- 8. Oil-return hose
- 9. Oil-supply hose for the wheel-free lift
- 35. Wires (for cable slack protective device, for electromagnets and height limit switches)
- 36. CHAIN protection
- 38. Hex socket cylinder head screw M6*60
- 39. Nut M6

2. Connect the hydraulic hoses.

Read the scheme for connecting hydraulic hoses.

Connect hoses (NO.7, 8, 9) to the corresponding fittings reserved at the hydraulic block. Make sure to tighten the connectors.

Attention: Connect the hose NO.10 to the slave cylinder of the wheel free lift only after the main platform is raised.

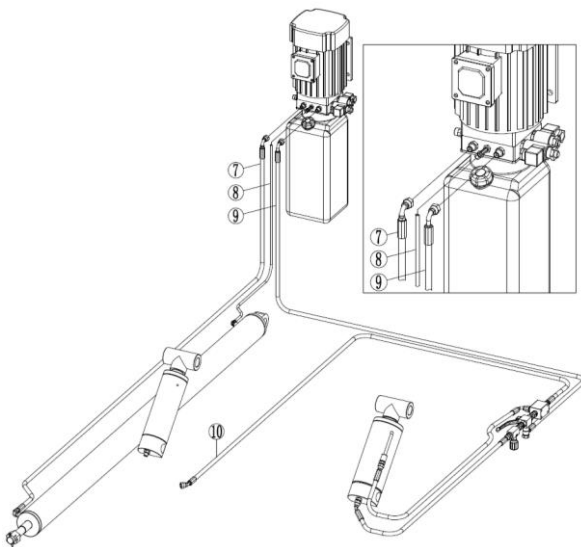

3. Connect the electrical system.

ONLY qualified electricians are permitted to do the electrical connection.

Refer to electrical connection schemes in Annex 3 before making connection.

Attention: For three phase power supply, if the lift doesn't raise and the motor may turn in the wrong direction, in such event, interchange wires U, V in the control cabinet.

Step 10: Fill with hydraulic oil

ONLY CLEAN AND FRESH OIL ONLY .Lift must be fully lowered before changing or adding hydraulic oil.

Totally, it needs 12 liters of anti-abrasion hydraulic oil.

Firstly, fill about 10 liters oil into the oil tank. The level of oil shall reach the tippets volume mark of the tank. After the “wheel free lift “ has been synchronized, lower the platform of the “main lift “and “wheel free lift” to the lowest position and refill the oil tank until it is full which needs another 2 liters of hydraulic oil.

It is recommended to use HM NO.46 hydraulic oil. Use HM NO.32 hydraulic oil when average temperature of the location is below 10 degree Celsius.

Change the oil 6 months after initial use and change once per year thereafter.

Step 11: Trial commission

1. Check the electrical connection with electrical schemes to ensure that all wires are correctly connected.

Inspect steel cables at four corners of the two crossbeams to ensure that all cables are correctly in pulley slots and are not twisted with each other. (See Annex 1 for steel cable connection scheme)

2. Turn on the main power switch and push slightly the button for raising to check if the motor runs in the correct direction. (In case the motor runs in wrong direction, interchange wires U, V in the control cabinet.) Check oil hoses to ensure all connectors are tight against leakage.

3. Push the button for raising until steel ropes are stretched tightly. Check the steel ropes again to ensure they are in the pulley slots and are not twisted.

4. Push the button for raising until the main lifting platform is raised to a height about 800mm above floor. After that connect the hose NO.10 to the slave cylinder of the wheel free lift.

5. Push the “DOWN I” button for lowering. The main lifting platform will stop lowering when it has a clearance about 300mm over the foundation. Push the other button “DOWN II” for lowering which accompanies with acoustic warning until the main lifting platform is completely lowered.

Step 12: Aligning and levelling

Attention: No vehicle on platforms for levelling operation.

Firstly, align the level at four corners of the runway when mechanical safety locks are released.

Switch on and push the UP button. Push the up button until the runway stays at a height about 800mm over the floor. Measure at the four corners of the runway to see if the height are almost the same. Check with a tape measure. The deviation of the liquid level shall be within 5mm. In case the deviation exceeds 3mm, correspondingly adjust the nuts (NO.40) attached with cable over the top plate of the post until the deviation is controlled within 3mm.

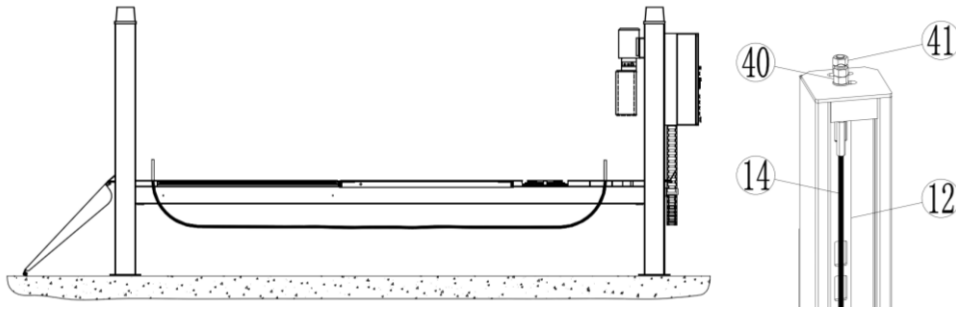

Secondly, align the level at four corners of the runway when mechanical safety locks are engaged.

Push the up button until the runway stays at a height about 800mm over the floor. Push the LOCK button to park the runway.

Measure at the four corners of the runway to see if the height are almost the same. Check with a tape measure. The deviation of the liquid level shall be within 5mm. In case the deviation exceeds 3mm, correspondingly adjust the nuts (NO.41) attached with safety ratchet over the top plate of the post until the deviation is controlled within 3mm.

Attention: In case of poor foundation level, you will not be able to control the deviation through making the above adjustment. In this case you have to place equalizing plates (NO.42) under the base plate to ensure the verticality of each post.

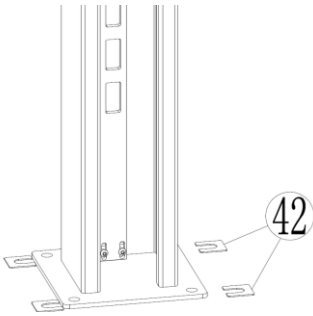

Step 13: Make proper adjustment to the switches of the cable slack protection system.

Park the runway at a height about 800 mm above the foundation. Adjust the switches using hex socket spanner with a specification of 3mm. See the flowing fig. to get the advised scope for adjustment.

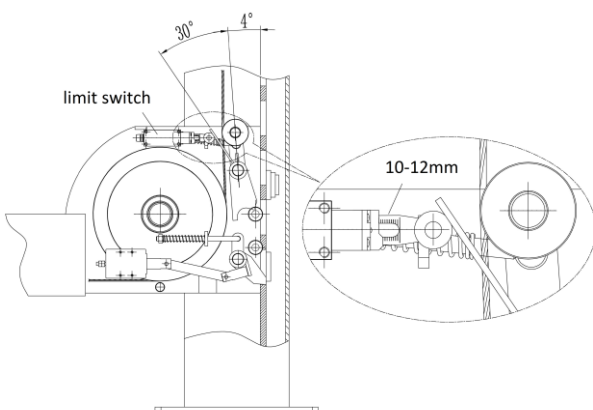

Step 14: Secure the post with by anchoring bolts.
Screw torque: 80Nm.

Before anchoring, it is necessary to check again the position for each post properly by referring to the dimension scheme as well as the corresponding installation requirements.

- Drill holes using D18 carbide tipped masonry drill bit. Make sure to drill vertically down. Depth of the hole should be no less than 120mm.
- Clean the hole and check again the position of the posts to ensure they are correctly positioned.
- Use a spirit level to check the vertical alignment of the lifting posts. If necessary, place equalizing plates under the base plates.
- Impact and drive anchoring bolt into hole until nut and washer contact base.
- Tighten the nut with torque wrench to 80Nm.

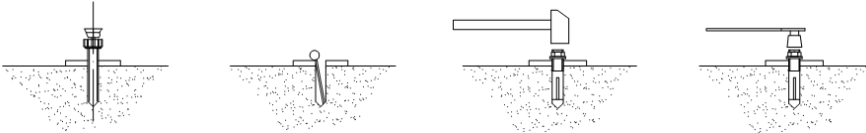
Step 15: Fix motor housing and post caps.

Fix the housing with the plate for hanging power unit

Place the cap onto each post.

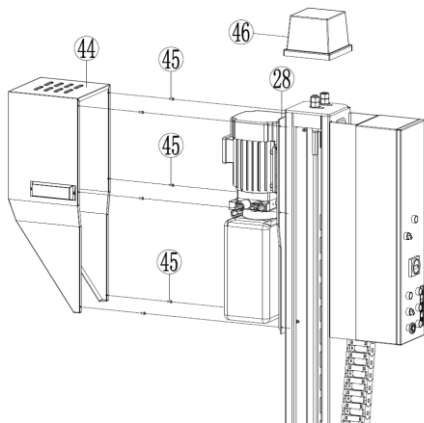

44. Motor housing

45. M4*14 cross socket cap head screw

46. Post cap

28. Plate for hanging power unit

Step 16: Fix the front wheel retainers and drive-on ramps.

1. Fix the front wheel retainer (NO.47) onto the front end of each platform.
 2. Hold the oil hoses on the crossbeam with protective sheath (NO.49) and hex socket cylinder head screw (NO.50).
- And then put on the covering plate (NO.51) and fix it with the crossbeam using M8*40 hex head full threaded bolts (NO.52)

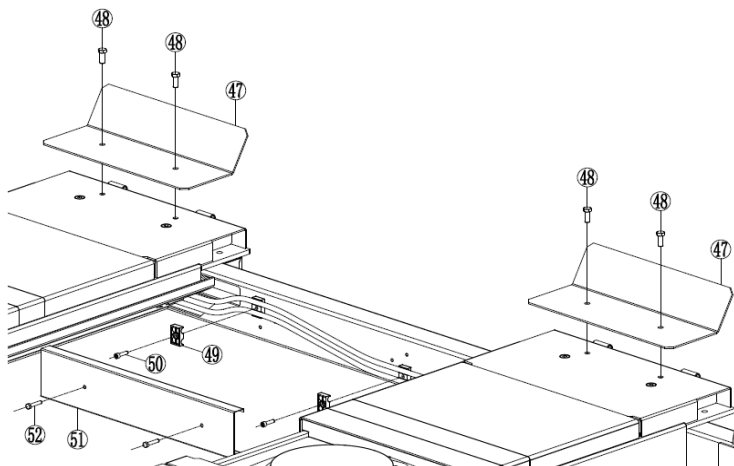

47. front wheel retainer

48. M12*30 hex head full threaded bolts

49. protective sheath

50. M8*30 hex socket cylinder head screw

51. covering plate

52. M8*40 hex head full threaded bolts

3. Mount the drive-on ramp (NO.53) onto the rear end of each lifting platform using pin shafts (NO.54) and cotter pins (NO.55).

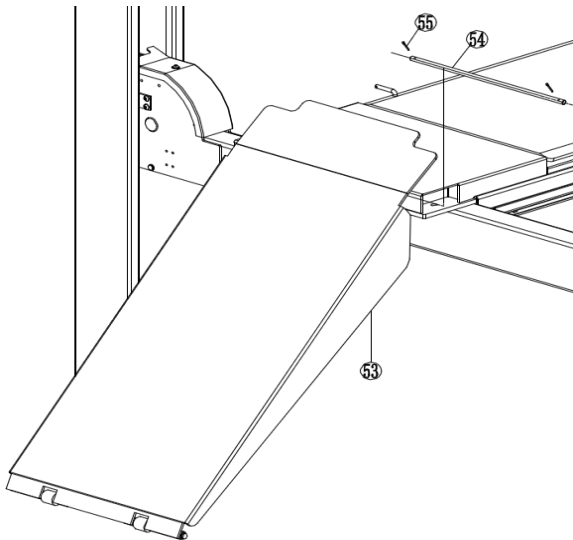

53. drive-on ramp

54. pin shaft

55. cotter pin

Step 17: Level the wheel free lift

1. Turn on the power switch and turn the selection switch to the “main lift”. Push the “UP “button until the platform of the main lift rises about 1 meter above the ground. (This is to find the levelling valve under the secondary platform of the main lift)



2. Find the valve under the secondary platform of the main lift and turn its handle making it point to the floor.

3. Turn the selection switch to the “wheel free lift” and push the UP button until the secondary platform of the wheel free lift starts to rise.

4. Turn the handle of the valve to its default position (with handle in the direction showing in the above picture) and push the UP button until the two platforms of the wheel free lift are at the same level.

5. Normally, platforms of the wheel free lift are synchronized after step 4. If not, repeat the above levelling steps until both platforms work synchronously.

4.4. Items to be checked after installation

S/N	Check items	YES	NO
1	Screw torque of expansion bolts : 70-80Nm;		
2	Rising speed ≥ 20 mm/s;		
3	Noise with rated load ≤ 75 dB;		
4	Grounding resistance: not bigger than 4 Ω ;		
5	Height difference of the two platform ≤ 5 mm;		
6	Mechanical locks are robust and synchronized when running with rated load ;		
7	If the control button works as "hold to run"?		
8	If limit switches work well?		
9	If grounding wire is connected?		
10	If the lift rises and lowers smoothly?		
11	If there is no abnormal noise during running with rated load?		
12	If there is no oil leakage when running with rated load?		
13	If expansion bolts, nuts or circlips are well secured?		
14	If max lifting height is 1850mm?		
15	If safety advices, name plate and logos are clear?		

OPERATION INSTRUCTIONS

5.1 Precautions

- ONLY authorized persons are permitted in the lift area.
- Do not try to raise the vehicle with excessive length or width. Otherwise there is risk of vehicle falling from lift.
- Inspect the space above and below the load and the loading carrying devices. It shall be free of obstructions before operating.
- Before raising operation, run the lift without load for a complete cycle to ensure it is in good condition.
- Before lifting the vehicle and during all operations on the vehicle, make sure that it is properly stopped by the hand brake.
- Check the vehicle after raising a short distance to ensure that it is correctly and safely positioned.
- It is forbidden for people to stand in the field of motion during raising or lowering movement.
- The load carrying device shall be observed by the operator throughout the motion of the lift.
- Engage the safety locking mechanism before entering under the raised vehicle.
- Avoid excessive rocking of vehicle while on the lift
- Do not climb onto the load or load carrying device when they are raised.

5.2 Descriptions of control panel

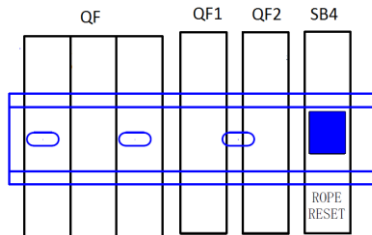
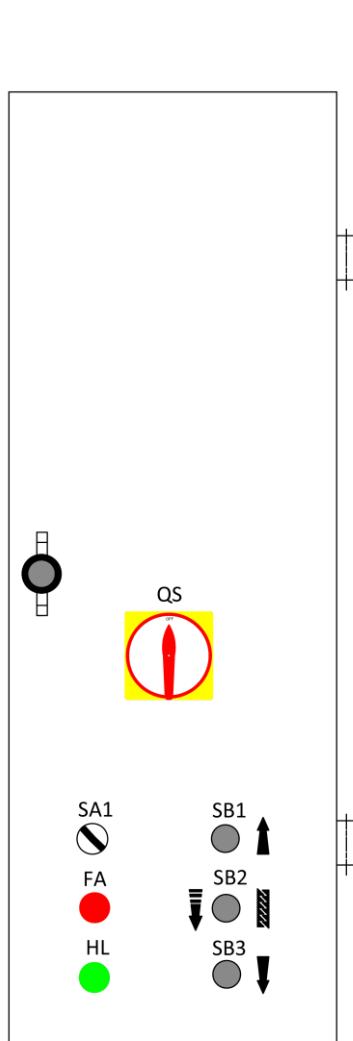

POS.	Name	Function
FA	Alarm buzzer	Low height warning
QS	Power switch	Power on/ off
HL	Power indicator	Display if electricity is connected
SB1	UP button	Control the rising movement
SB3	DOWN I button	Control the initial lowering movement
SB2	Safety lock /DOWN II button	1.1 In case the clearance between the platform and the floor is more than 300mm, push DOWN II button to lock the platform. 1.2 In case the clearance between the platform and the floor is less than 300mm, push DOWN II, the platform will continue lowering to the lowest position which accompanies with acoustic alarm.
SB4	Reset button	As the lift is equipped with 'out of level protection system', in case one of the steel cables is slacken, the control buttons will stop functioning. In this case the operator can push this button and DOWN button to lower the platform.
SA1	Selection switch	Select using wheel-support lift or wheel-free jack.

5.3 Operation instructions

The lift must be only used in a static position for lifting and lowering vehicles.

Only use this lift on a surface that is stable and capable of sustaining the load. Do not install the lift on any asphalt surface.

To avoid personal injury and/or property damage, permit only trained personnel to operate the lift. After reviewing these instructions, get familiar with lift controls by running the lift through a few cycles before loading vehicle on lifting platform.

Caution:

Before raising, make sure vehicle is neither front nor rear heavy and center of balance should be centered over the lift.

Before push the button for lowering, pay careful attention that all personnel and objects are kept clear.

5.3.1 Use the main WHEEL-SUPPORT lifting platform

Turn the selection switch to “WHEEL-SUPPORT lifting platform”

RAISING

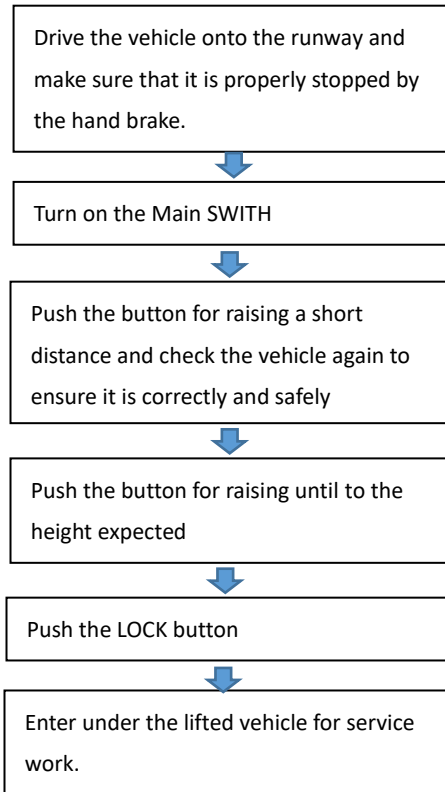

LOWERING

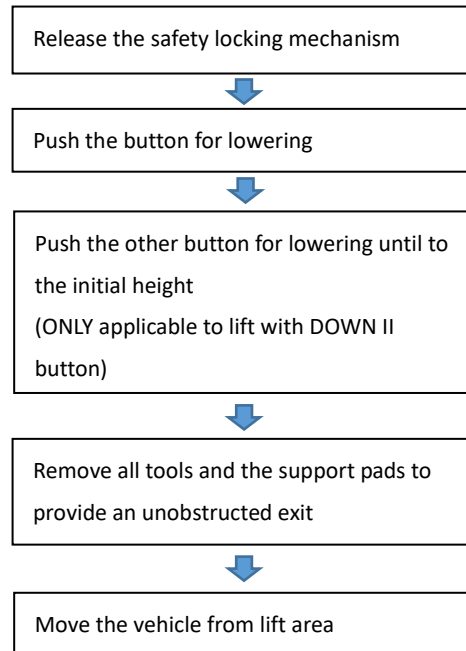

5.3.2 Use the wheel free lift

Full rise of the jack is 450mm over the platform of main lift.

Turn the selection switch to “WHEEL-FREE JACK”

RAISING

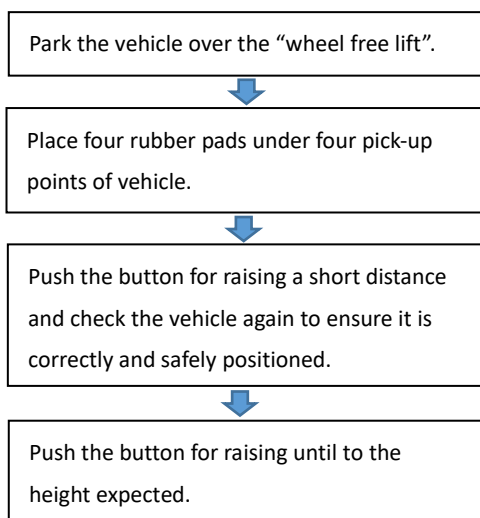

LOWERING

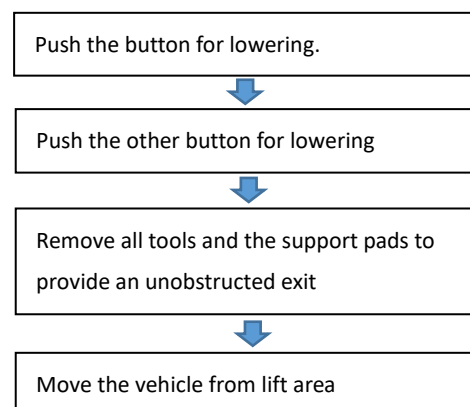

Attention:

When it is necessary to use the platform extensions, the operator has to raise platforms of the jack a bit over the runway of main lift and then pull out the extensions for raising operation. For lowering operation, pay careful attention to retract the extension after the wheel free lifting platform is unloaded.

5.4 Emergent lowering in case of no power supply

Prepare a manually operated pump with its hose being attached with M14*1.5 straight fitting (No.61).

Prepare four bolts dimensioned M6*40

1. Disassemble the motor housing.
2. Connect the manually operated pump to the reserved access at the hydraulic block. Before making the connection, you have to remove the hydraulic plug (No.60) from the hydraulic block using a hex socket wrench.

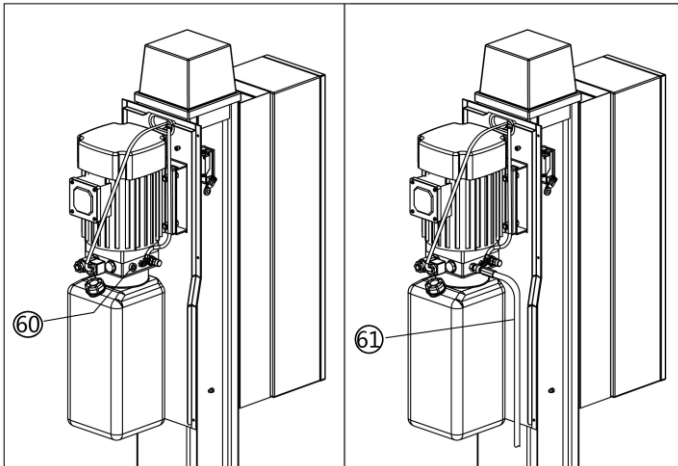

3. Raise the lift using the pump until the mechanical locking device is released.
4. Detain the block (No.64) and adjustable post (No.65) at four corners of the crossbeam using M6*40 bolts so as to keep disengaging the mechanical safety device.

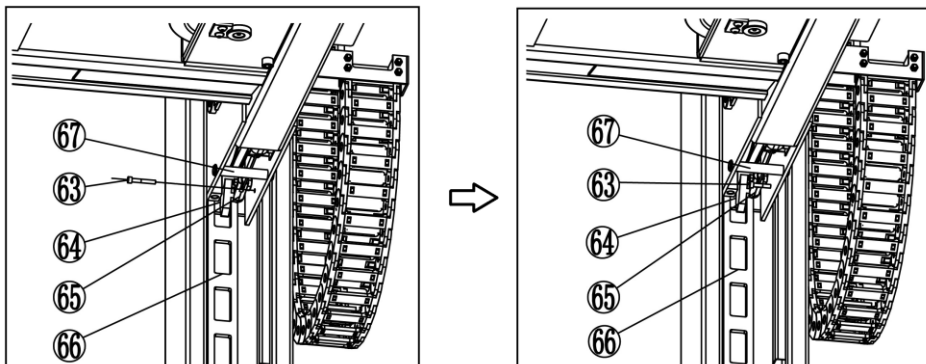

5. Push and turn clockwise the red lever of the unloading valve (No.68) and the platform will lower slowly.

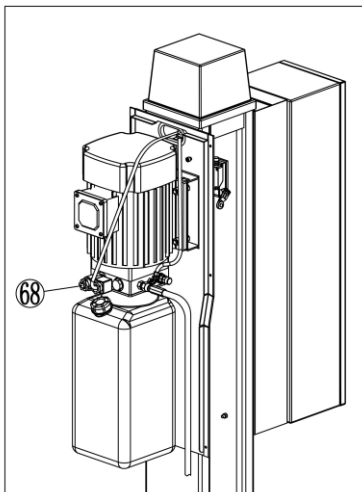

TROUBLE SHOOTING

ATTENTION: If the trouble could not be fixed by yourself, please do not hesitate to contact us for help.

We will offer our solutions at the earliest time we can.

Troubles could be judged and solved much faster when more details or pictures could be provided.

TROUBLES	POSSIBLE CAUSE	SOLUTION
Abnormal noise	Abrasion exists on insides surface of the posts.	Grease the inside of the post.
	Trash in the post.	Clear the trash
Motor does not run and will not rise	Loose wire connection	Check and make a good connection.
	Blown motor.	Replace it.
	Damaged limit switch or its wire connection is loose.	Adjust or replace the limit switch.
Motor runs but will not rise	The motor run reversely.	Check the wire connection.
	Overflow valve is not well screwed up or jammed.	Clean or make adjustment
	Damaged gear pump.	Replace it.
	Too low oil level.	Add oil.
	The hose connection is loose.	Tighten it.
	The cushion valve is not well screwed up or jammed.	Clean or make adjustment
Platforms go down slowly after being raised	The oil hose leaks.	Check or replace it.
	Untightened oil cylinder.	Replace the seal.
	The single way valve leaks.	Clean or replace it.
	The overflow valve leaks.	Clean or replace it.
	Solenoid valve fails to work well.	Clean or replace it.
Rising too slow	Slack steel cable	Check and adjust the tightness.
	Jammed oil filter	Clean or replace it.
	Too low oil level.	Add oil.
	The overflow valve is not adjusted to the right position.	Make adjustment.
	Too hot hydraulic oil (above 45°) .	Change the oil.
	Abraded. Seal of the cylinder	Replace the seal.
Lowering too slow	Inside surface of the posts is not well greased.	Add grease.
	Jammed throttle valve	Clean or replace.
	Dirty hydraulic oil	Change the oil.
	Jammed anti-surge valve	Clean it.
The steel cable is abraded	Jammed oil hose	Replace it.
	No grease at installation or out of lifetime	Replace it.

MAINTENANCE

Easy and low cost routine maintenance can ensure the lift work normally and safely. Following are requirements for routine maintenance. Follow the below routine maintenance schedule with reference to the actual working condition and frequency of your lift.

LUBRICATE moving parts with lithium grease.

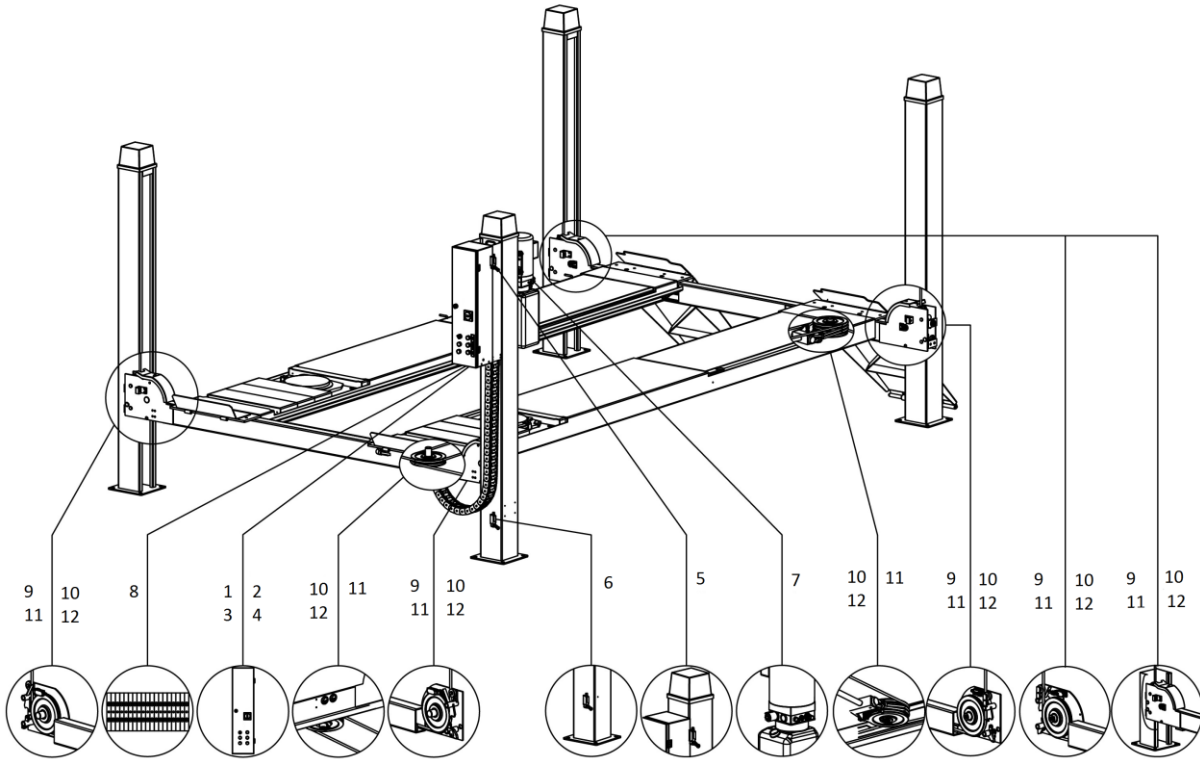

S/N	Components	Methods	Period
1	Control buttons	Check if control buttons work as "hold- to -run " and check if they work as the function indicated.	Every day
2	Synchronization of the ascending movement	Push the UP button, check and ensure the four mechanical safety blocks give off sound simultaneously. Both runways shall rise steadily without abnormal sounds.	Every day
3	Synchronization of mechanical safety catch	Push the LOCK button, inspect and ensure the four mechanical safety catches are fully engaged at the same height. Front the rear side of the runway shall be of the same level.	Every day
4	Synchronization of the descending movement	Push the DOWN button, inspect and ensure both runways can descend smoothly.	Every day
5	Max height limit switch	Push the UP button and inspect and ensure the runways stop rising at maximum lifting height.	Every week
6	Safety lowering limit switch	Push the DOWN I button. Inspect and ensure the runways stop lowering at safety height (300mm) and then push DOWN II button to have the platform fully lowered.	Every week

S/N	Components	Methods	Period
7	Hydraulic valves	Remove the motor housing. Inspect if any valve leaks. Clean or change the valve if it leaks.	Every 3 months
8	Electrical terminals	Open the control box to inspect all wire terminals. Screw firm if any terminal connection is loose.	Every 3 months
9	Limit switch of the "out of level" protection unit	Take off the protection covers fixed at both ends of the crossbeam. Push the UP button and meanwhile use suitable means to activate one of the limit switches. The lift must stop rising when the limit switch is activated.	Every 3 months
10	Steel cables	Lubricated with NO.1 lithium grease. Change with new steel ropes every 2 years or ten single wires have broken.	Every 3 months
11	Pulley	Lubricated with NO.1 lithium grease. Replace with new pulley in the case that: 1) Surface cracks 2) Uneven slot: bigger than 3mm 3) Over-wearing. 20% of pulley slot is abraded	Every 3 months
12	Shaft of the pulley	Add grease.	Every 3 months
	Sliding blocks	Add grease.	Every 3 months
	Whole lift	Running the lift for several cycles with and without rated load. The lift can run steadily and smoothly with no abnormal noise.	Every 3 months
	Hydraulic oil	Change the oil 6 months after initial use and once per year thereafter. Inspect the hydraulic oil and change the oil if the oil becomes black or there is dirt in the oil tank.	Every year

Additional care shall be paid to the painting surface so as to maximally avoid rust to steel mechanical structures.

1. Avoid rubbing against the paint surface with sharp and hard metal components.
2. Keep overheated light source away from the paint surface.
3. Keep the paint clean and dry, and remove in time the salty substance, snow and water from the paint surface. If there is water gathered in the gap of the platform, it has to be wiped up and dried as soon as possible.
4. The oil contaminated paint surface can be cleaned with ordinary household cleaning agent. Corrosive solvent, detergent powder or metal wire cleaning tools shall not be used. Soft fabrics like cotton gauzes and soft towels are recommended to wipe the paint surface.
5. Check the paint surface regularly. Deep scratches or peelings must be repaired in time, otherwise, due to the infiltration of water, oxidation and rust will be accelerated. Epoxy paint is recommended for the repair.
6. Wax regularly.

If users stick to the above maintenance requirements, the lift will always keep a good working condition and its service life could be extended.

Annex 1, Steel cable connection

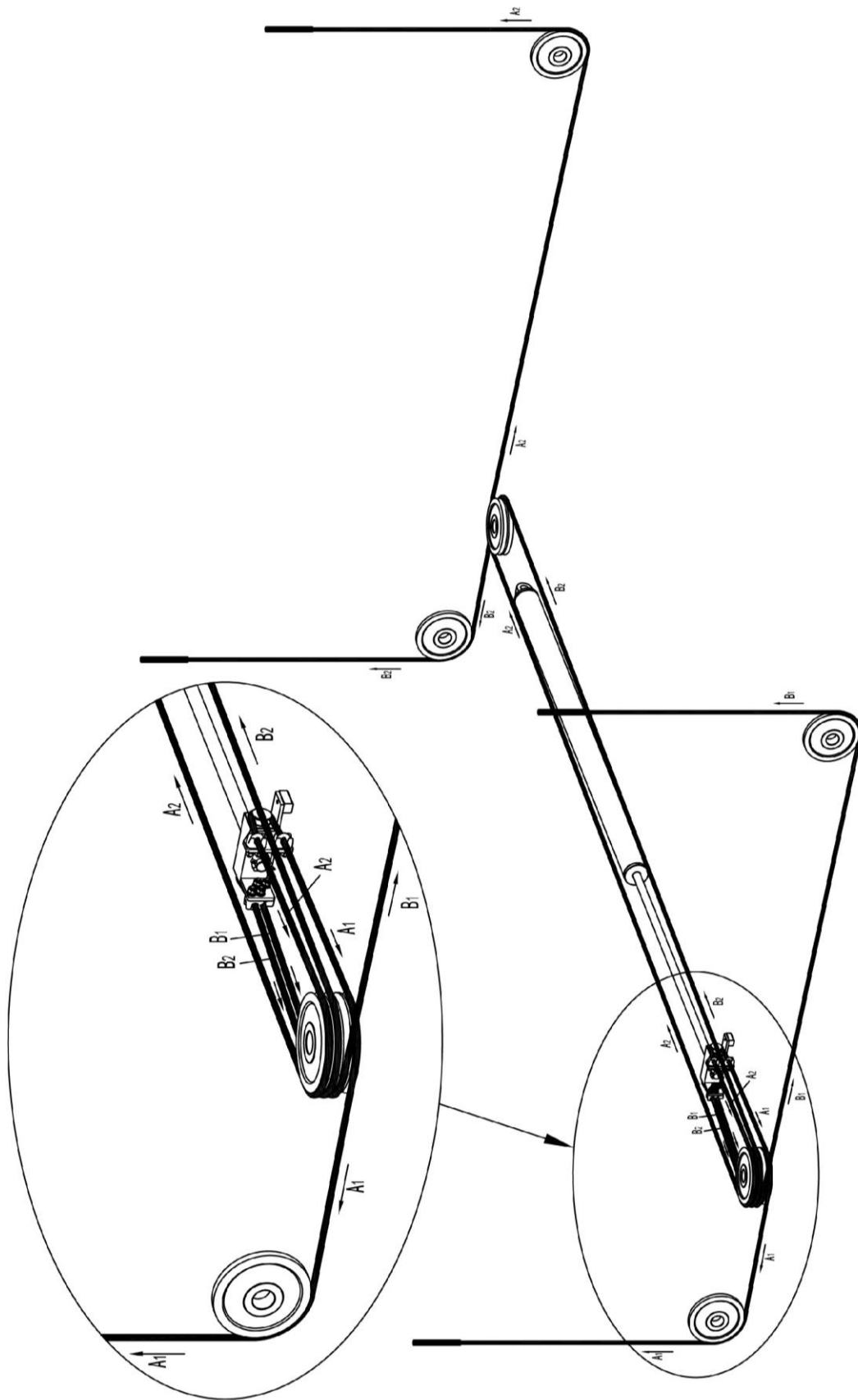

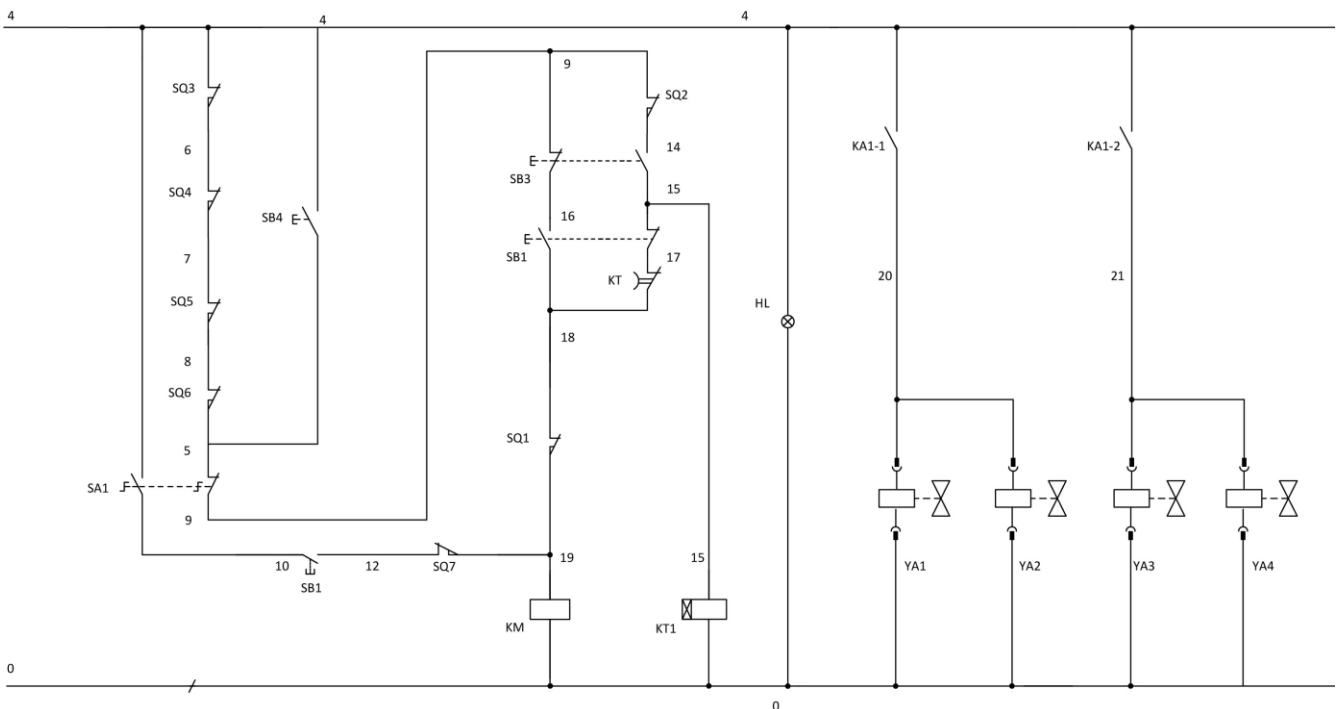
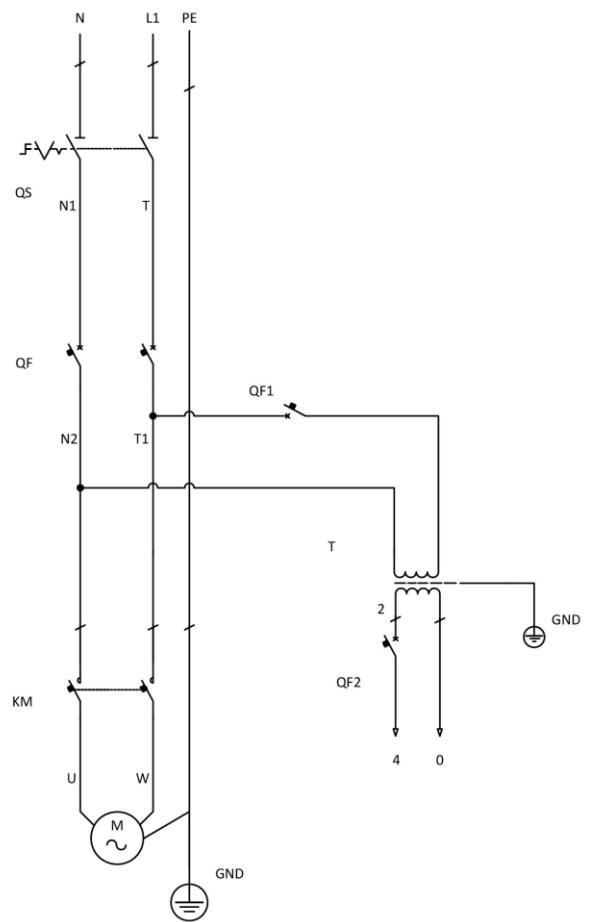
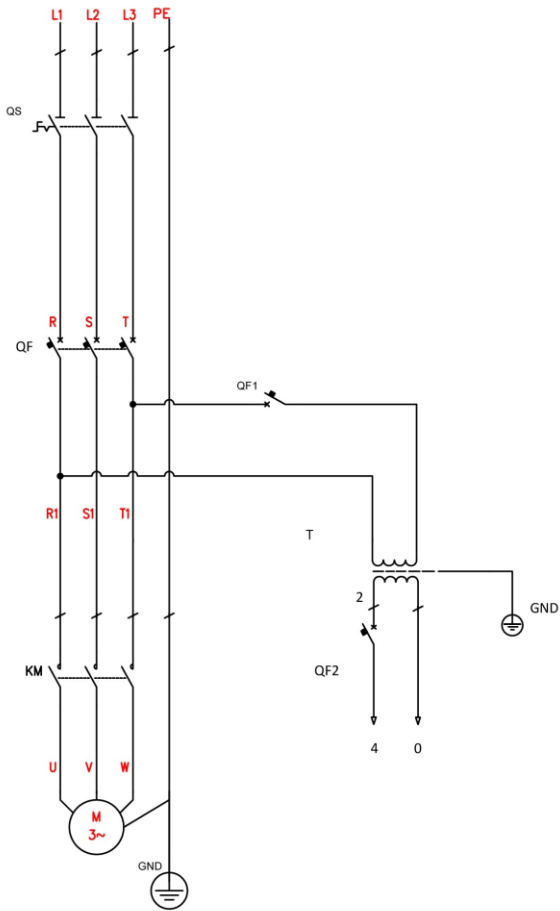
Annex 2, Electrical schemes and parts list

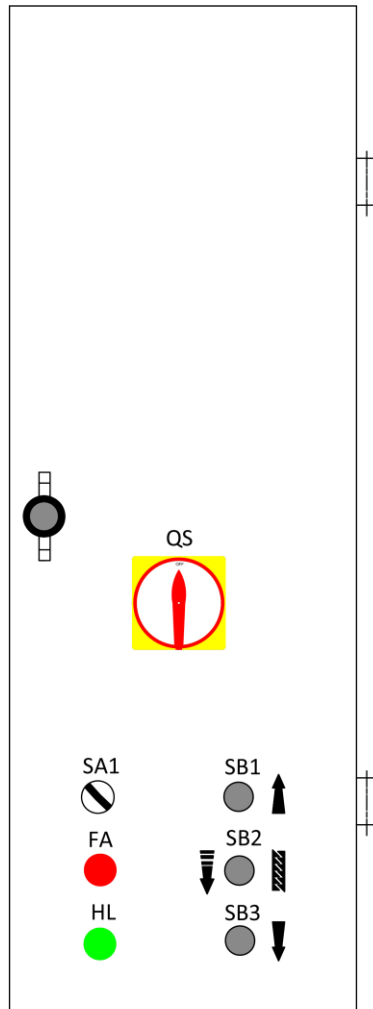
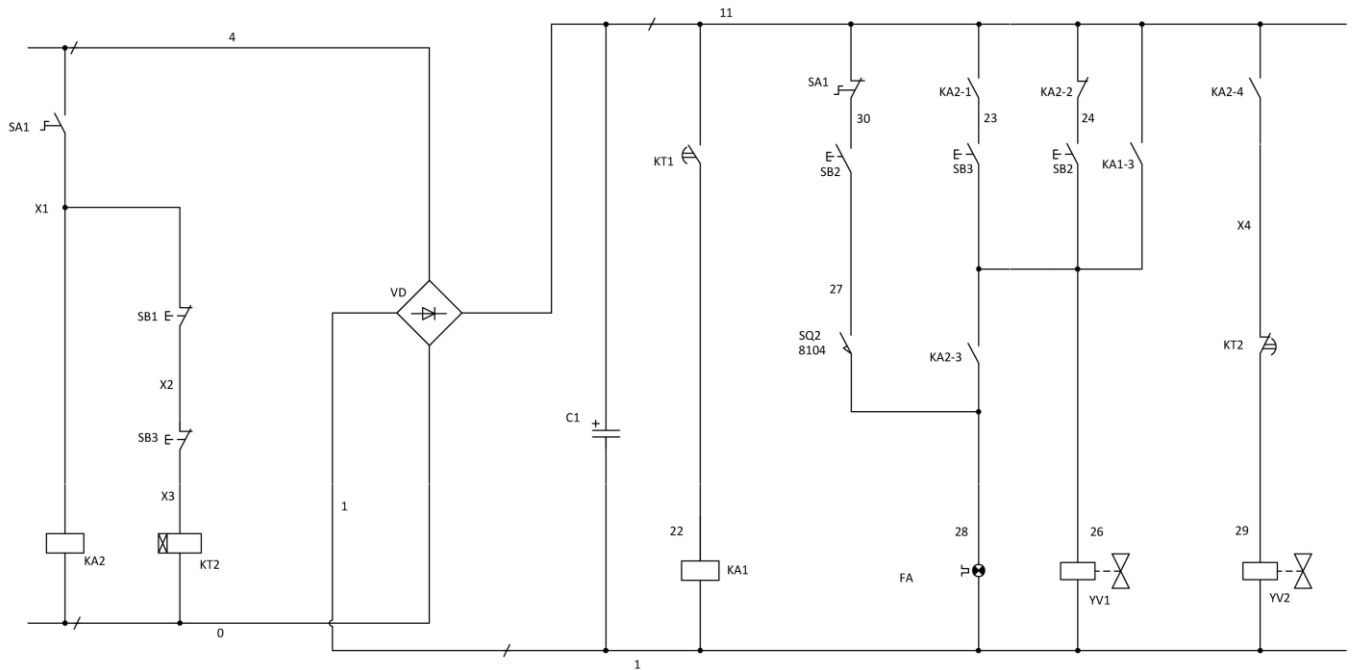

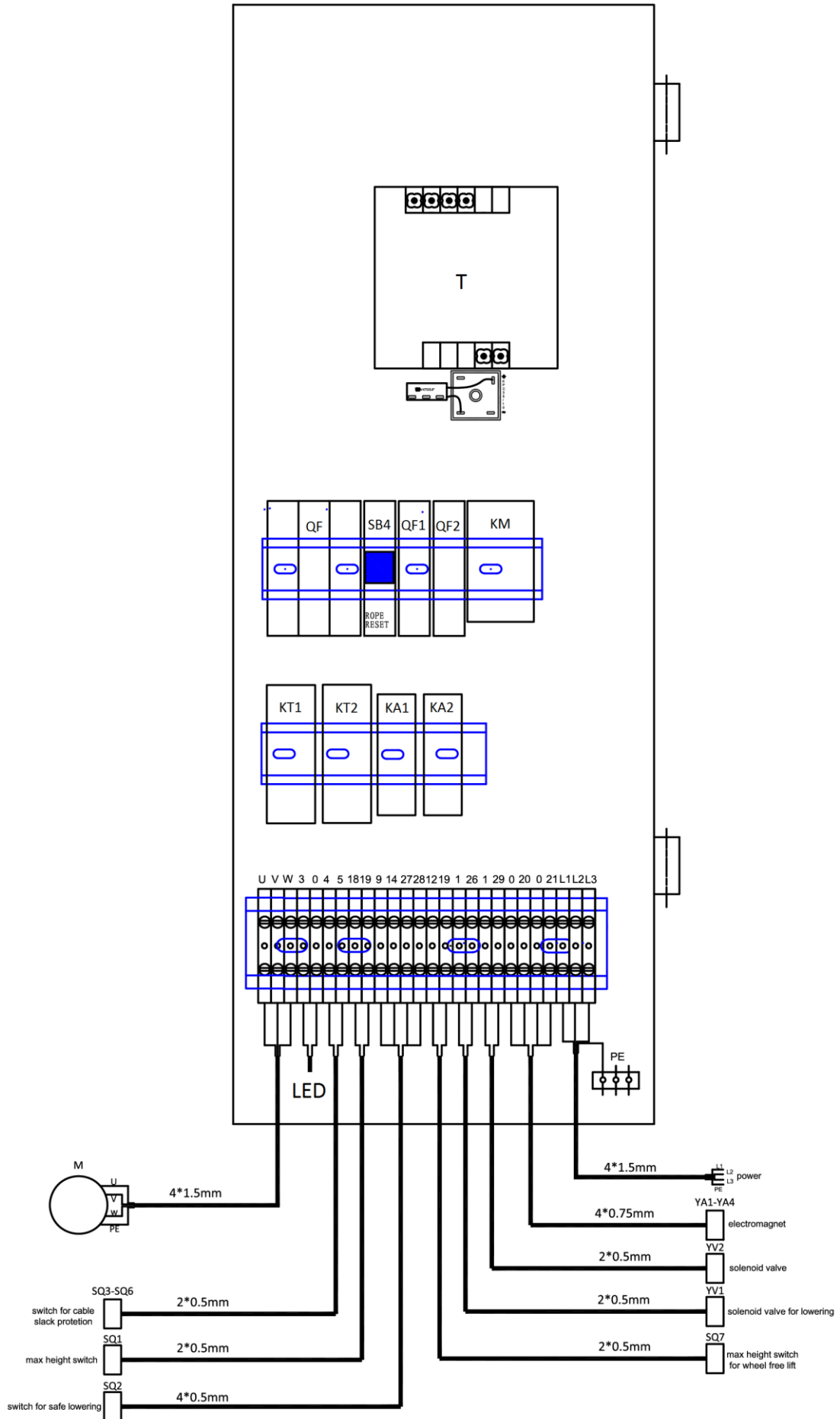

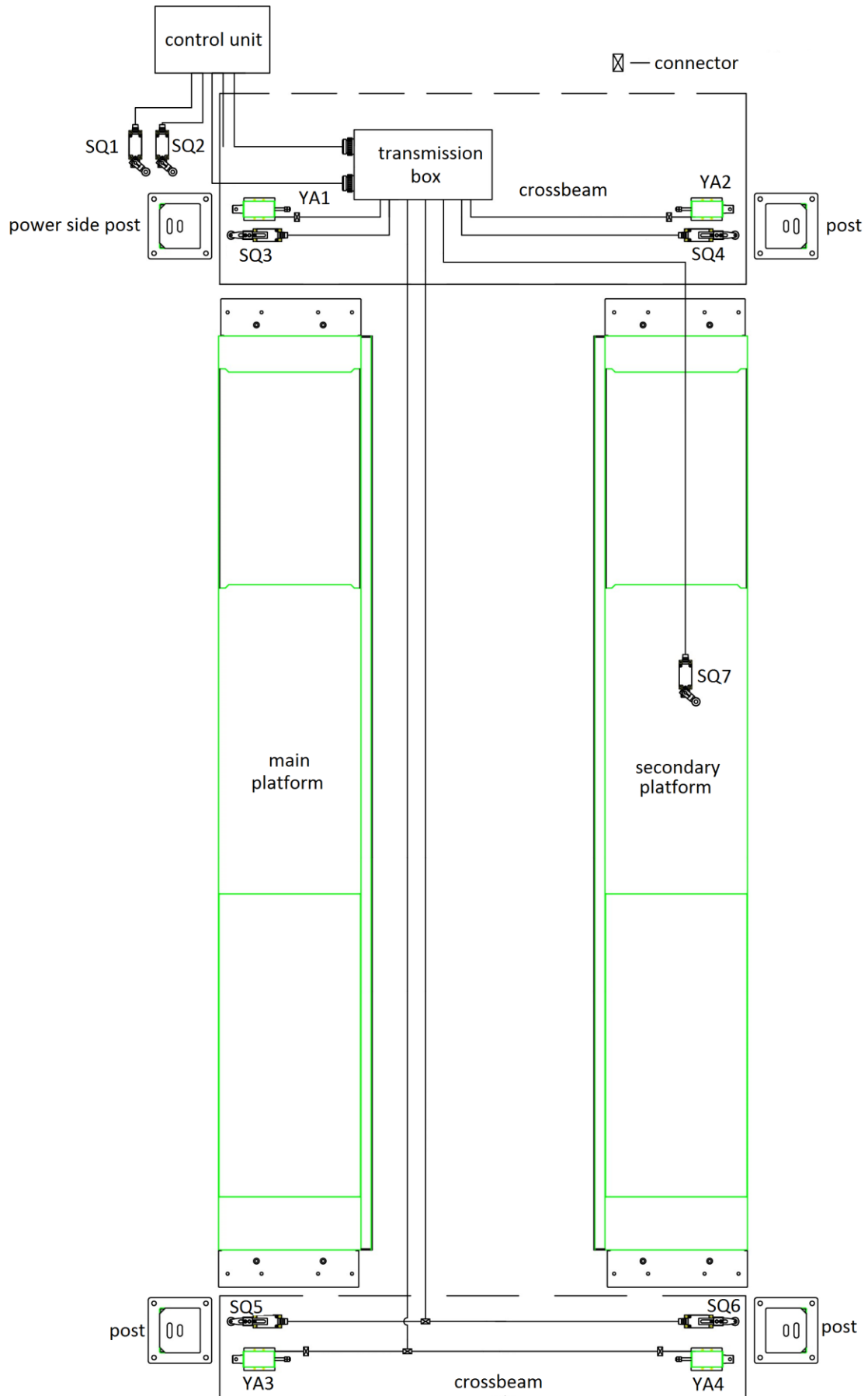

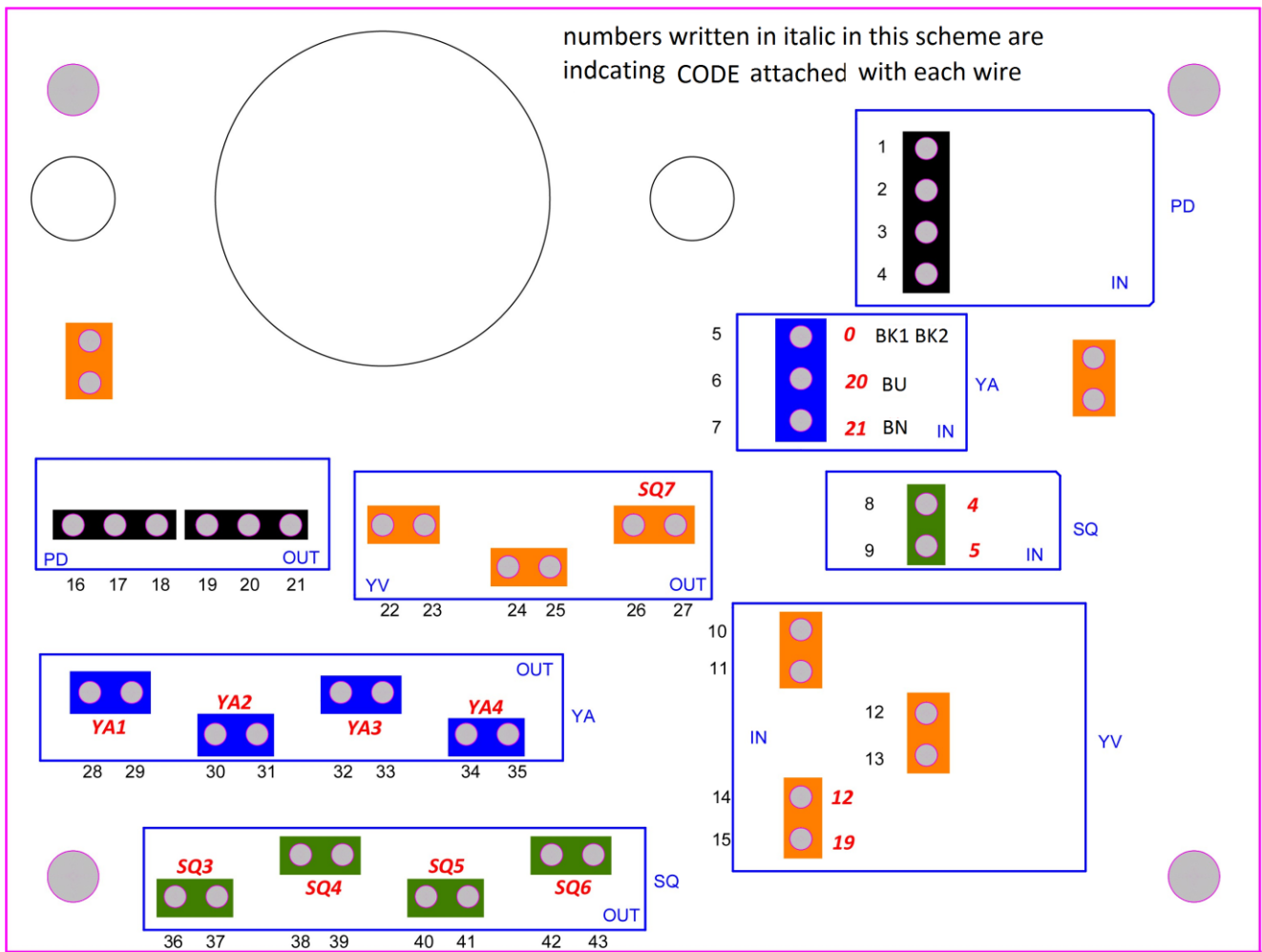

Printed Code	Terminal	Color	CODE marked at wire terminals	Route Description
5.6.7	3P	BLUE	21.20.0 (two NO.0 wires share one terminal)	From main control box to the transmission box (for four electromagnets)
8.9	2P	GREEN	4.5	From main control box to the transmission box (for four limit switches of the "out of level protection system".)
14.15	2P	ORANGE	12.19	From main control box to the transmission box (max height switch for the wheel-free jack)
26.27	2P	ORANGE	SQ7	From transmission box to the max height switch for wheel-free jack
28.29	2P	BLUE	YA1	From transmission box to electromagnet in the post
30.31	2P	BLUE	YA2	From transmission box to electromagnet in the post
32.33	2P	BLUE	YA3	From transmission box to electromagnet in the post
34.35	2P	BLUE	YA4	From transmission box to electromagnet in the post

Printed Code	Terminal	Color	CODE marked at wire terminals	Route Description
36.37	2P	GREEN	SQ3	From transmission box to the limit switch of the "out of level protection system" in the post
38.39	2P	GREEN	SQ4	From transmission box to the limit switch of the "out of level protection system" in the post
40.41	2P	GREEN	SQ5	From transmission box to the limit switch of the "out of level protection system" in the post
42.43	2P	GREEN	SQ6	From transmission box to the limit switch of the "out of level protection system" in the post

Optional LED lighting assembly

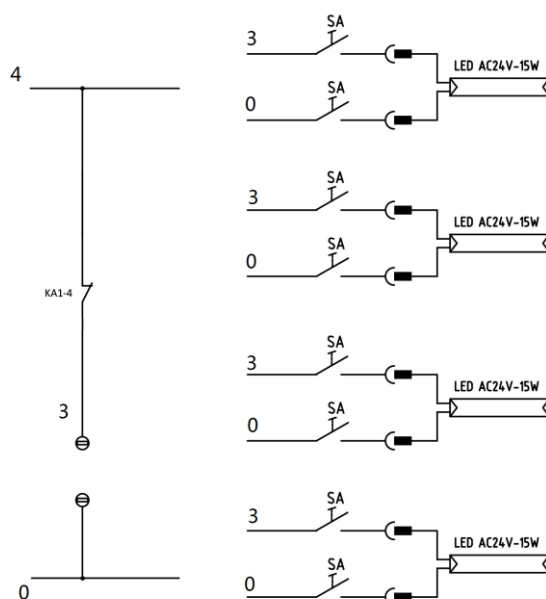

POS.	CODE	Description	Qty
T	320104008	Transformer 380V400V415V-24V	1
T	320104007	Transformer 220V230V240V-24V	1
M	320201004	Motor	1
SQ1,SQ2,SQ3	320301009	Limit switch 8104	3
SQ4,SQ5,SQ6,SQ7	320301011	Limit switch 8108	4
SA1	320303020	Selection switch	1
QS	320304001	Power switch	1
SB1, SB3	320401051	Button	2
SB2	320401038	Button	1
SB4	320401034	Button	1
KA2	320601002	Relay	1
KA1	320601007	Relay	1
KT1,KT2	320602009	Integrated time relay	1

POS.	CODE	Description	Qty
QF	320801001	Circuit breaker (3Ph)	1
QF	320802001	Circuit breaker (1Ph)	
QF1	320803014	Circuit breaker (4A)	1
QF2	320803007	Circuit breaker(16A)	1
KM	320902014	AC contactor (2.2Kw/3.5kW)	1
C	321001004	Capacitor	1
VD	321002001	Bridge rectifier	1
HL	321201001	Power indicator	1
FA	321202001	Alarm buzzer	1
YA1,YA2,YA3,YA4	330310007	Electromagnet	4
SA	320305002	Rocker switch (optional)	4
LED	321201021C	LED lamp(optional)	4

NOTE: For power supply of other voltages, the transformer is different.

Please check with our customers service people when order spare parts.

Annex 3, Hydraulic schemes and parts list

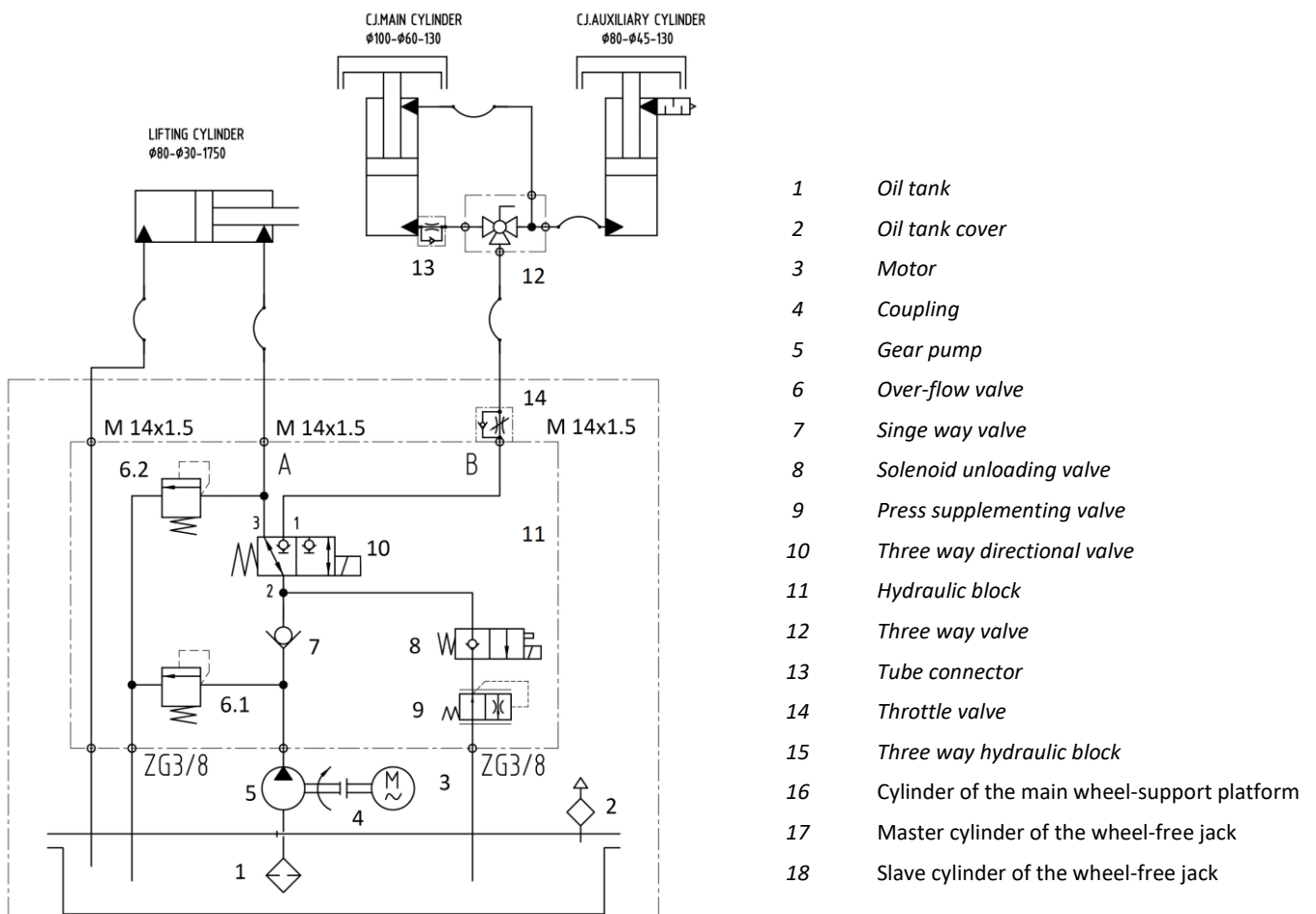

Seal Rings

Cylinder Code	Seal ring description	Seal ring code	Seal ring specification	Qty	Category
615027005	Type Y seal ring	207102008	B7-80*65*9	1	Cylinder of the main wheel-support platform
	Type Y seal ring	207102019	B7-80*70*6	1	
	Guiding ring	207106024	80*76*10	2	
	Type Y seal ring	207102010	BS30*40*6	2	
	Guiding ring	207106020	30*34*10	2	
	Dust proof ring	207105011	DHS30 (30*38*5/6.5)	1	
615027097	Type Y seal ring	207103033	B7-100*85*9	2	Master cylinder of the wheel-free jack
	Type Y seal ring	207103023	BS60*70*6	2	
	Dust proof ring	207105009	DHS60 (60*68*6)	1	
615027098	Type Y seal ring	207102008	B7-80*65*9	1	Slave cylinder of the wheel-free jack
	Dust proof ring	207105008	DHS45 (45*53*6)	1	

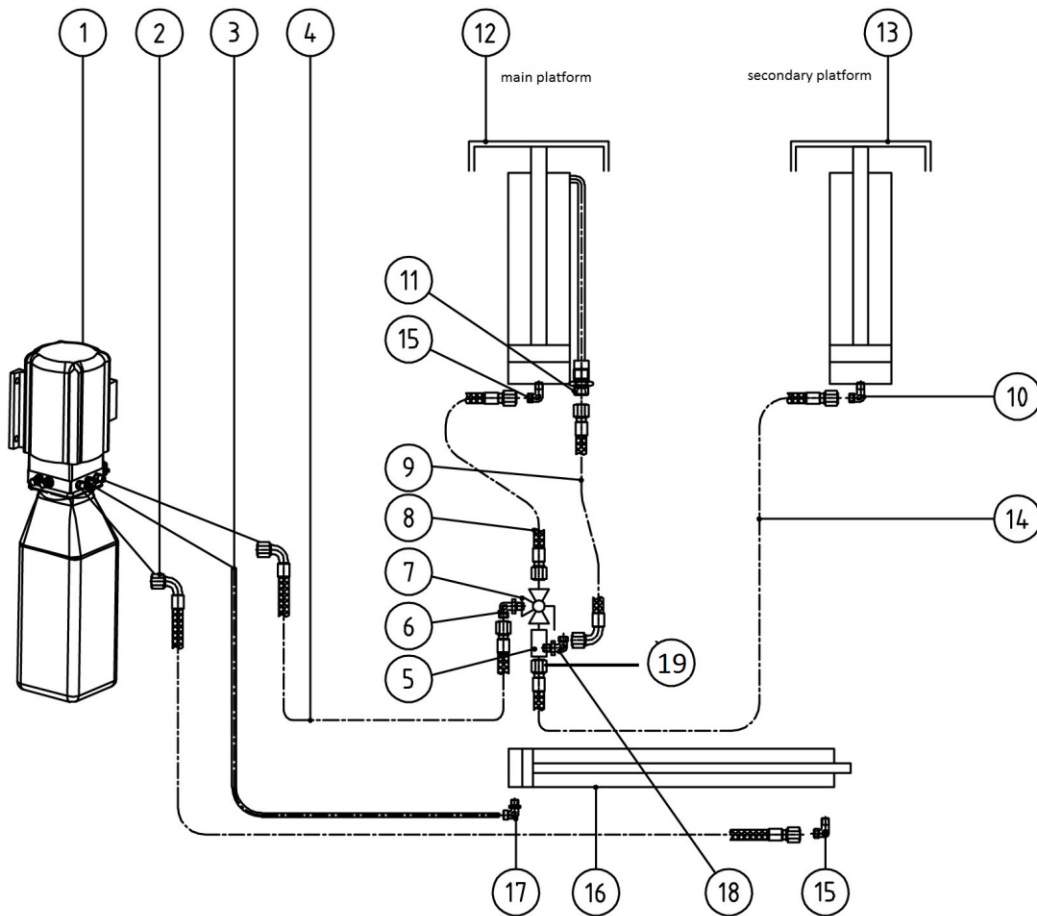

Pos.	CODE	Description	Specification	Qty	REMARK
1		Power unit	2.2kW	1	
2	624001864	Oil hose	L=5750	1	48L
2	624001867	Oil hose	L=6150	1	52L
2	624001242	Oil hose	L=6650	1	57L
3		PU hose	L=4250	1	48L
		PU hose	L=4650	1	52L
		PU hose	L=5500	1	57L
4	624001942	Rubber oil hose	L=6850	1	48L/52L/57L
5	330503014	T shape three way hydraulic block	3-G1/4	1	
6	310102013	Right angle connector	08N-M14S	1	
7	330306001	Three way ball valve	GE3L-G1/4-DN6	1	
8	624001255	Oil hose	L=1150	1	48L/52L
8	624001002	Oil hose	L=1350	1	57L
9	624001259	Oil hose	L=1450	1	48L/52L
9	624001003	Oil hose	L=1650	1	57L
10	310101010	Straight connector	G1/4---G1/4	2	
11	615019005	Right angle connector	6501-A4-B16	1	
12	615027097	Master cylinder of the wheel-free jack	6604B-A11-B1	1	
13	615027098	Slave cylinder of the wheel-free jack	6604B-A12-B1	1	
14	624001865	Rubber oil hose	ø8,L=6150	1	48L/52L
14	624001869	Rubber oil hose	ø8,L=6300	1	57L
15	615018001	Right angle throttle valve	MR30-A24-B16	2	
16	615027005	Cylinder of the main wheel-support platform	5T-6435B-A3-B19	1	
17	310102013	90 degree connector with swivel	08N-M14S	1	
18	310101010	Straight connector	G1/4-G1/4	1	
19	330305004	Restrictive valve	DVG-R-DN8 G1/4-1A	1	

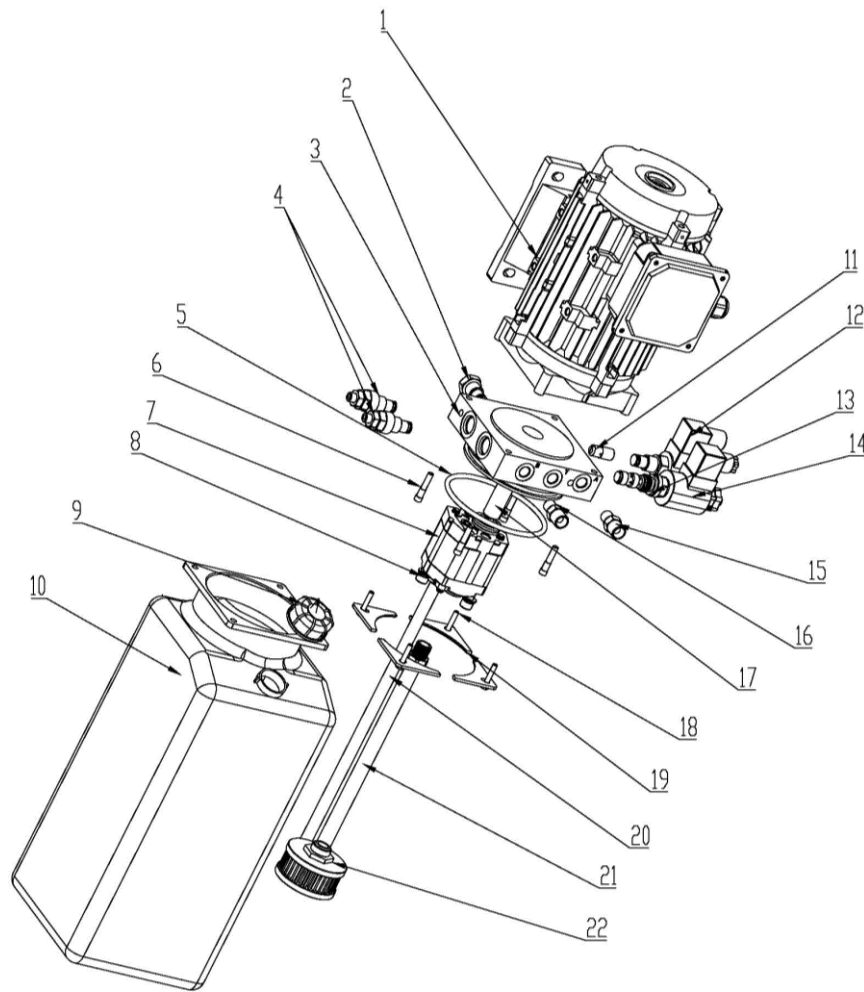

Pos.	Code	Descriptions	Specification	Qty
1	320201004	Motor	380V-2.2KW-3PH-50HZ-2P	1
1	320201005	Motor	400V-2.2KW -3PH-50HZ-2P	1
1	320203005	Motor	400V-3.5KW -3PH-50HZ-2P	1
2	330302006	Non-return valve	DF08-01-00	1
3	330105062	Hydraulic block	LA10791	1
4	330304007	Relief valve	YF08-40	2
5	207101166	Type O seal ring	110*5	1
6	202109064	Hex socket cylinder head screw	M6*30(NLJD)	4
7	330201010	Gear pump (2.2kW motor)	CBK-F225-H (CBKA-F2.5DF2)	1
7	330201012	Gear pump (3.5kW motor)	CBK-F242-H	1
8	202109071	Bolt	M8*80	1
9	330405070	Lid of the tank	10L(Ø28)	1
10	330405001	Oil tank	10L	1
11	330308043	Pressure balance valve	BLF-06-05-00	1
12	791150005	Solenoid unloading valve assembly	24DC(Ketai)	1
13	330311012	Valve spool for the 2P3W solenoid valve	LSV-08-3-L	1

Pos.	Code	Descriptions	Specification	Qty
14	330308039	Round 3-plug coil	HC-C-16-D24	1
15	310101010	Straight connector	G1/4---G1/4	1
16	207103025	Composite washer	13_7X20X1_5	2
17	330404001	Coupling	46mm	1
18	201103001	Hex flange screw	M5x25	4
19	410010091	Reinforced plate for oil tank	6254E-A4-B12(6254A-A5-B12 50*50*4)	4
20	330402001	Oil -return tube	YH-D	1
21	330401005	Oil sucking tube	XYGN-L293	1
22	330403001	Filter	YG-C	1

NOTE: The motor is different for different voltage or capacity.

Please check with our customers service people when order spare parts.

Annex 4, Exploded drawings and parts list

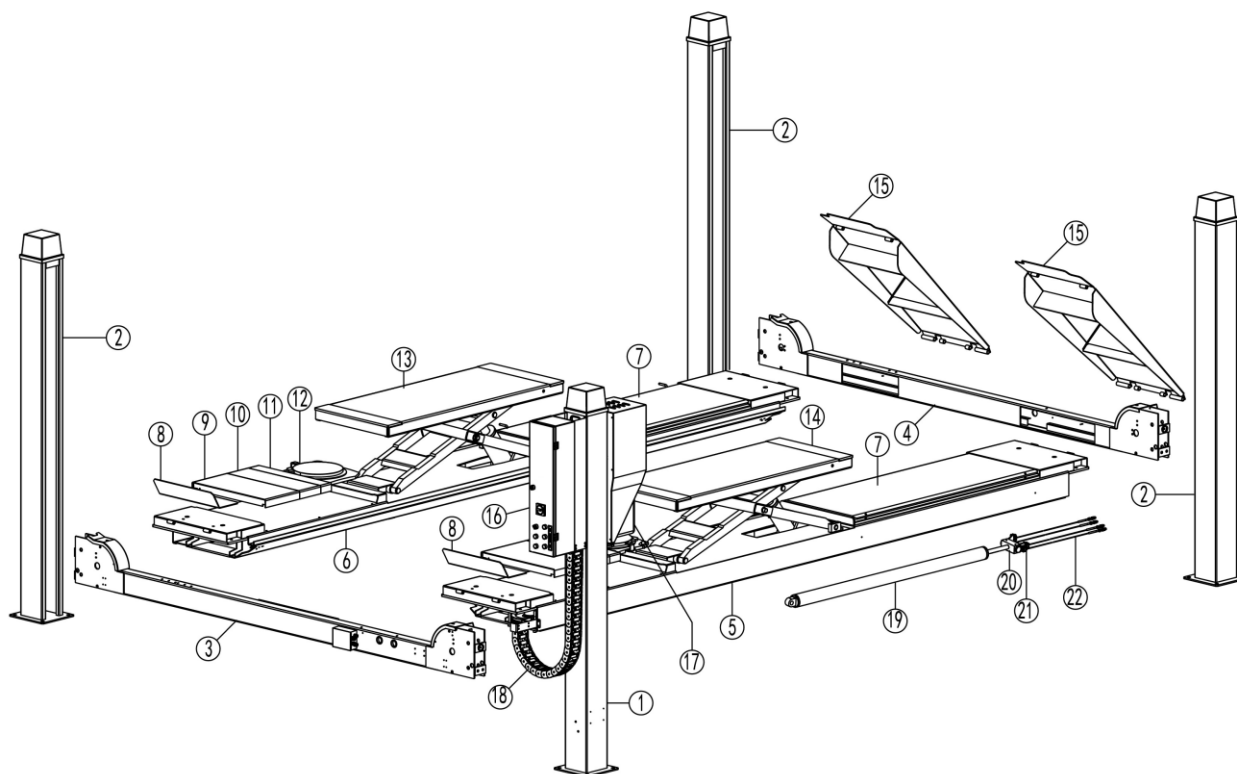

Pos.	Description	QTY	NOTE
1	Power side post B	1	
2	Secondary post	3	
3	Power side crossbeam	1	
4	Secondary crossbeam	1	
5	Main platform	1	
6	Secondary platform	1	
7	Slip plate	2	



Pos.	Description	QTY	NOTE
8	Front wheel retaining plate	2	
9	Portable box I--389	2	48L/52L/57L
10	Portable box II-199	2	57L
11	Portable box III-89	4	48L/52L/57L
12	Turntable (optional)	2	
13	Auxiliary lifting platform (main)	1	
14	Auxiliary lifting platform (secondary)	1	
15	Drive-on ramp	2	
16	Control unit	1	
17	Power unit	1	
18	Plastic chain	1	
19	5T oil cylinder	1	
20	Steel rope connection block	1	
21	Steel rope clip	4	
22	Steel rope	2	48L
22	Steel rope	2	52L
22	Steel rope	2	57L

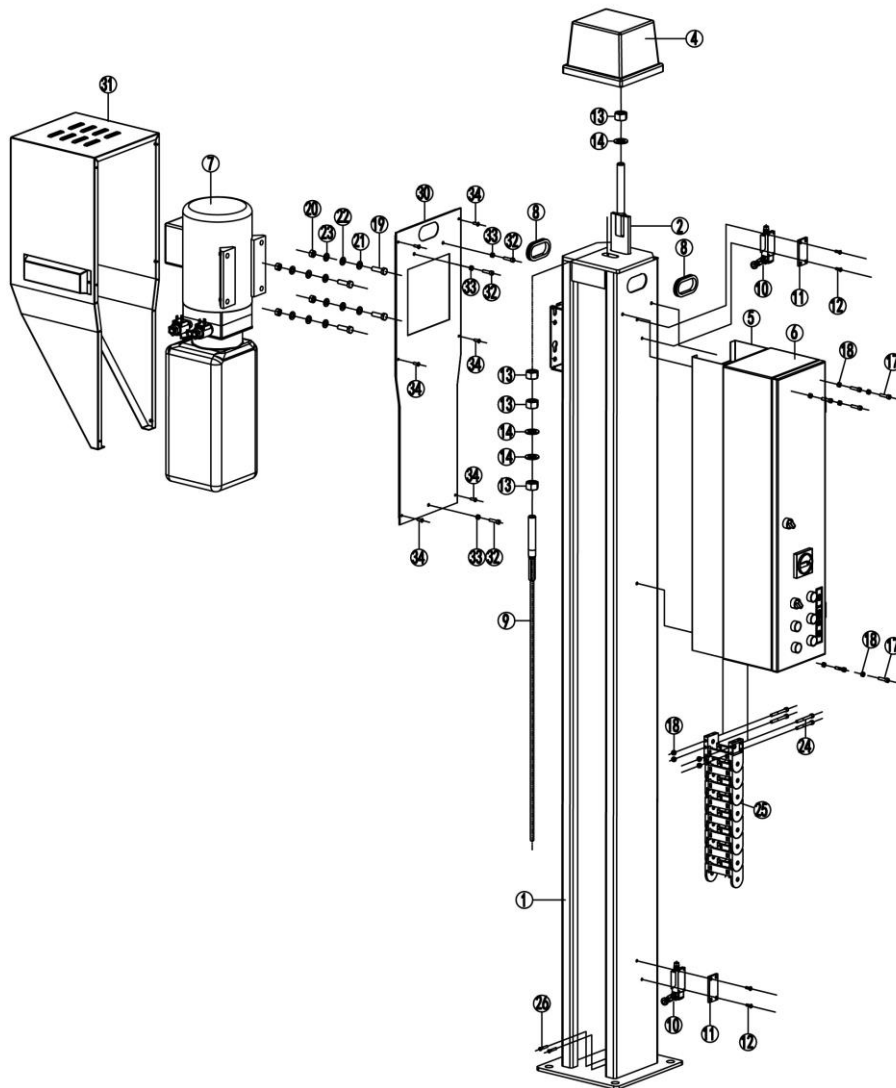

Pos.	CODE	Description	Specification	QTY
1	614027703	Main post	6435B-A1-B3	1
1	614027091B	Secondary post	6435B-A1-B1	3
2	612027001B	Safety rod	6435B-A1-B2	4
4	420270090	Post cap	6435B-A11	4
5	614027108	Control unit holder	6435B-A1-B4--V2	1
6		Control unit		1
7		Power unit		1
8	420250050B	Round hose protector	6604B-A17	2
9	615027038B	Steel rope (48L, L=13050)	6435B-A3-B29	2
9	615027037B	Steel rope (52L, L=13450)	6435B-A3-B29	2
9	615027036	Steel rope (57L, L=13980)	6435B-A3-B29	2
10	320301009	Limit switch	TZ-8104	2
11	410270221	Padding plate of limit switch	6435B-A23	2
12	202110009	Hex socket button head screw	M5*16	4
13	203101012	Hex nut	M20	8
14	204101011	Flat washer	M20	4
17	202109020	Hex socket cylinder head screw	M6*15	6
18	203101004	Hex nut	M6	14
19	201103004	Hex head full swivel screw	M10*35	4
20	203101006	Hex nut	M10	4
21	420040010	Anti-vibration pad	6254E-A23	4
22	204201005	Spring washer	M10	4
23	204101006	Flat washer	M10	4
24	202109026	Hex socket cylinder head screw	M6*60	4
25	208101007B	Plastic chain	TL-2	1
26	202110005	Hex socket button head screw	M8*20	4
30	614027609	Plate for hanging power unit	6435BWF-A1-B8-C1	1
31	614027610	Motor housing	6435BWF-A1-B8-C2	1
32	202109020	Hex socket cylinder head screw	M6*15	3
33	203101004	Hex nut	M6	3
34	202101009	Cross socket cap head screw	M4*14	8

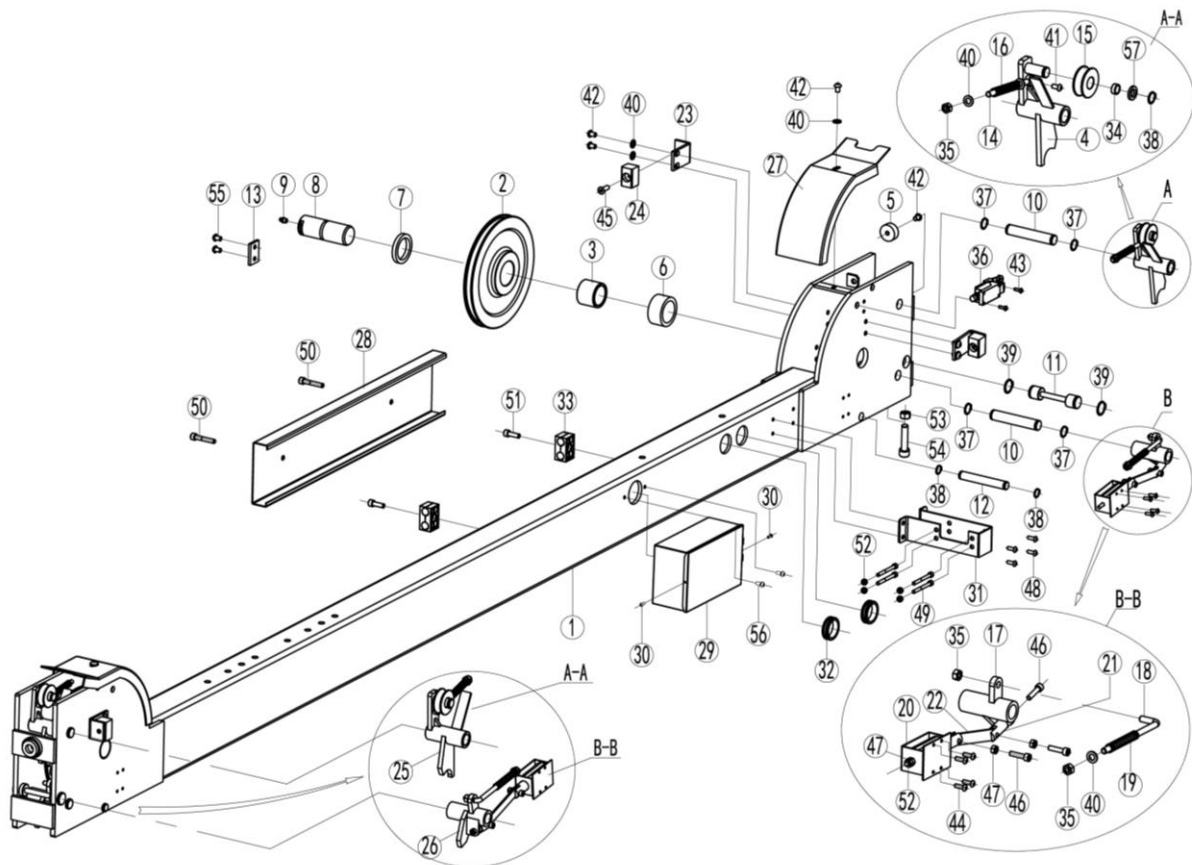

Pos.	CODE	Description	Specification	QTY
1	614027613	Main crossbeam	6435B-A2-B1-48LB--V2	1
1	614027614	Secondary crossbeam	6435B-A2-B2-48LB--V2	1
2	410274120C	Pulley A	410274120	4
3	205101070	Lubrication bearing	40*50*40	4
4	612027002	Safety block A	6435B-A3-B6	2
5	420270020	Side slider block	6435B-A2-B4	4
6	420270050	Spacer A	6435B-A3-B1	4
7	420270060	Spacer B	6435B-A3-B2	4
8	410270021	Pulley shaft A	6435B-A3-B4	4
9	208106001	Straight pressed oil cup	M8*1	4
10	410270071	Shaft I	6435B-A3-B10	8
11	410270081B	Shaft II	6435B-A3-B11	4
12	410270091	Shaft III	6435B-A3-B12	4
13	410270101B	Shaft block	6435B-A3-B13	4
14	612027003	Adjustable rod B	6435B-A3-B9	4
15	410270031B	Small pulley	6435B-A3-B5	4
16	410270630	Spring	6435B-A3-B22	4
17	410270051D	Safety block B1	6435B-A3-B7	2

Pos.	CODE	Description	Specification	QTY
18	410270061	Adjustable rod A	6435B-A3-B8	4
19	410270660	Spring	6435B-A3-B32	4
20	330310007	Electromagnet	(MQB3-10-20/AC24V)	4
21	410270601	Adjustable post	6435B-A3-B33	4
22	410270151	Adjustable chip	6435B-A3-B34	4
23	410270011	Slider holder	6435B-A2-B2	8
24	420270010	Slider	6435B-A2-B3	8
25	612027004	Safety block A2	6435B-A3-B16	2
26	410270121D	Safety block B2	6435B-A3-B17	2
27	420270040	Protection cover	6435B-A2-B5	4
28	410270133B	PD hose cover	410270133B	1
29	410293253	Wire connection box	6435B-A3-B39	1
30	202101009	Cross socket cap head screw	M4*14	4
31	614027301	Holder B for plastic chain	614027301	1
32	420040030	Oil hose protection ring	6254E-A21	2
33	420270070	Oil hose protective sheath	6435B-A3-B27	4
34	205101001	Lubrication bearing	1615	4
35	203103006	Hex nut M8	M8	12
36	320301011	Limit switch	TZ8108	4
37	204301007	Circlip	M20	16
38	204301005	Circlip	M16	12
39	204301009	Circlip	M25(23.2)	8
40	204101005	Flat washer	M8	36
41	202103012	Cross socket flat head screw	M6*16	4
42	202110004	Hex socket button head screw	M8*12	32
43	202110009	Hex socket button head screw	M5*16	8
44	202101008	Cross socket cap head screw	M4X10-GB818	8
45	202111035	Hex socket flat head screw	M8X25-GB70_3	8
46	202109022	Hex socket cylinder head screw	M6*25	6
47	203101004	Hex nut	M6	12
48	202110003	Hex socket button head screw	M6*12	4
49	202109026	Hex socket cylinder head screw	M6*60	4
50	201102015	Hex socket cylinder head screw	M8*40	2
51	202109031	Hex socket cylinder head screw	M8*30	2
52	203101004	Hex nut	M6	8
53	203101007	Hex nut	M12	4
54	202109087	Hex socket cylinder head screw	M12*70	4
55	202110004	Hex socket button head screw	M8*12	8

Pos.	CODE	Description	Specification	QTY
56	202101009	Cross socket cap head screw	M4*14	2

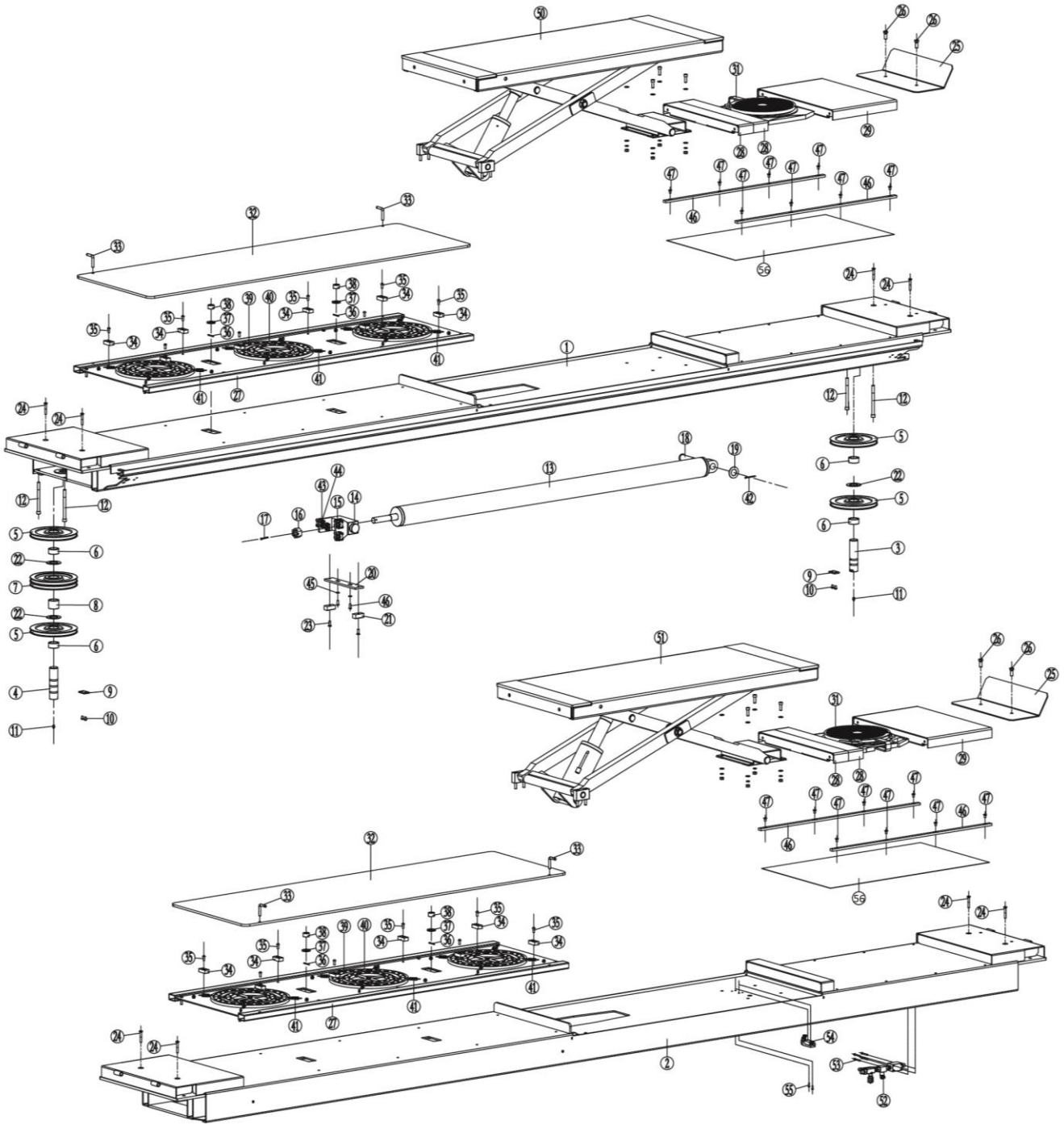

Pos.	Code	Description	Specification	QTY	NOTE
1	614901382	Master platform-4T48L	6435BWFV2-A4-B8-48L	1	
1	614901386	Master platform-4T52L	6435BWFV2-A4-B8-52L	1	
1	614901384	Master platform-5T48L	6435BWFV2-A5-B8-48L	1	

Pos.	Code	Description	Specification	QTY	NOTE
1	614901388	Master platform-5T52L	6435BWFV2-A5-B8-52L	1	
1	614901390	Master platform-5T57L	6435BWFV2-A5-B8-57L	1	
2	614901383	Slave platform-4T48L	6435BWFV2-A4-B9-48L	1	
2	614901387	Slave platform-4T52L	6435BWFV2-A4-B9-52L	1	
2	614901385	Slave platform-5T48L	6435BWFV2-A5-B9-48L	1	
2	614901389	Slave platform-5T52L	6435BWFV2-A5-B9-52L	1	
2	614901391	Slave platform-5T57L	6435BWFV2-A5-B9-57L	1	
3	410292411	Pulley shaft B	6435B-A4-B17	1	
4	410292421	Pulley shaft C	6435B-A4-B18	1	
5	410274130C	Pulley B	6435B-A4-B11	4	
6	205101069B	Lubrication bearing	JDB-405023	4	
7	410274140C	Pulley C	6435B-A4-B12	1	
8	205101070	Lubrication bearing	JDB-405040	1	
9	410270101B	Shaft retaining block	6435B-A3-B13	2	
10	202110004	Hex socket button head screw	M8X12	4	
11	208106001	Straight pressed oil cup	M8X1	2	
12	202109060	Hex socket button head screw	M12X145	4	
13	615027005	Cylinder of the main wheel-support platform	5T-6435B-A3-B19	1	
14	614027033B	Steel rope connection block	6435B-A4-B7	1	
15	208101001	Rope clip	10-6KTH-L_57MM	4	
16	/	Open slotted nut	M27	1	
17	/	Cotter pin	D5X45	1	
18	410270281	Cylinder shaft II	6435B-A4-B26B	1	
19	204101015	Flat washer	D30	1	
20	410290393	Oil cylinder guiding plate	6435BWF-A4-B24	1	
21	420270240	Guiding slider	6435B-A4-B23	2	
22	202110005	Hex socket button head screw	M8X20	2	
23	202111035	Hex socket flat head screw	M8X25	2	
24	202111028	Hex socket flat head screw	M12X80	8	
25	410274513	Front wheel retaining plate	6435B-A4-B10	2	
26	201102027	Hex head full swivel screw	M12X30	4	
27	614901392	Slip plate	6435BWF-A4-B10-48L	2	48L
	614901393	Slip plate	6435BWF-A4-B10-52L	2	52L
	614901394	Slip plate	6435BWF-A5-B10-57L	2	57L
28	614901396	Portable box III-89	6435BWF-A4-B21	4	48L/52L/57L
29	614901395	Portable box I-389	6435BWF-A4-B20	2	48L/52L/57L
	614901397	Portable box II -199 (Only for 57L)	6435BWF-A4-B22	2	57L
31	615027049	Turntable (optional)	HT-400X400X50	2	optional

Pos.	Code	Description	Specification	QTY	NOTE
32	614027583C	6435BWF.48L slip plate	6435BWF-A4-B3-48L	2	48L
	614027582C	6435BWF.52L slip plate	6435BWF-A4-B3-52	2	52L
	614027581C	6435BWF.57L slip plate	6435BWF-A5-B3-57L	2	57L
33	410250221B	Bolt	6604B-A16	4	
34	420680184	Padding block for slip plate	6435B-A4-B57	16/20	48L,52L/57L
35	202110005	Hex socket button head screw	M8X20	16/20	48L,52L/57L
36	206201007	Cotter pin	D4X30	4/6	48L,52L/57L
37	410250011	Washer	6604B-A1-B5	4/6	48L,52L/57L
38	420210030	Nylon sheath	6603B-A4-B7-C4	4/6	48L,52L/57L
39	420270100B	Ball holder	6435B-A4-B20	6/8	48L,52L/57L
40	420270110	Ball	6435B-A4-B21	240/320	48L,52L/57L
41	410274481	Pull spring	6435B-A4-B31	24/32	48L,52L/57L
42	206201011	Cotter pin	D4X50	1	
43	204101005	Flat washer	D8-GB95	8	
44	204201005	Spring washer	D10	8	
45	204101005	Flat washer	D8-GB95	2	
46	202110005	Hex socket button head screw	M8X20	2	
47	410901797	Limitation rod(48L/52L)	6435BWF-A4-B1-C33	4	
	410901845	Limitation rod(57L)	6435BWF-A5-B1-C35-57L	4	
50		Wheel-free lifting platform (master)		1	
51		Wheel-free lifting platform (slave)		1	
52		Hydraulic block assembly		1	
53	202109026	Hex socket cylinder head screw	M6*60	4	
54	320301009	Limit switch 8104	TZ-8104	1	
55	202110009	Hex socket button head screw	M5X16	2	
56	420680088	Magnetic pad	6435BWF-A4-B30	2	48L,52L
56	420680089	Magnetic pad	6435BWF-A4-B31	2	57L

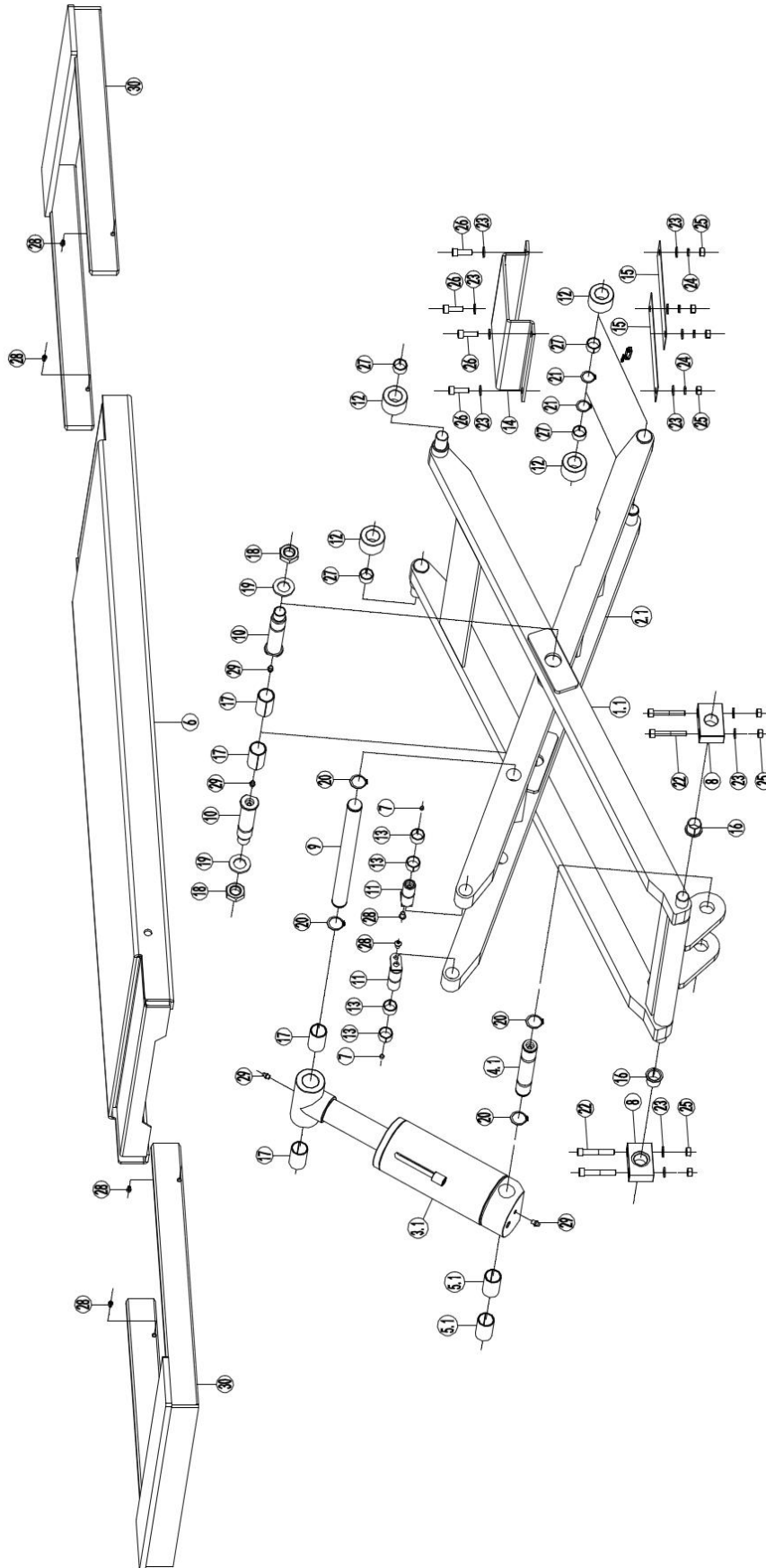

Pos.	CODE	Description	Specification	QTY
1	614027268B	Outer connection rod A of the wheel free lift	6435BWF-C03	1
1	614027269B	Outer connection rod B of the wheel free lift	6435BWF-C04	1
2	614027270B	Inner connection rod A of the wheel free lift	6435BWF-C05	1
2	614027271B	Inner connection rod B of the wheel free lift	6435BWF-C06	1
3.1	615027097	Master cylinder of the wheel-free jack	64040-D03	1
3.2	615027098	Slave cylinder of the wheel-free jack	64040-D04	1
4.1	410276741C	Down shaft A of oil cylinder	6435BWF-C03-24	1
4.2	410276751C	DOWN shaft B of oil cylinder	6435BWF-C03-25	1
5.1	205101023	Bearing	3050-SF-1X	2
5.2	205101021	Bearing	3040-SF-1X	2
6	614027584	Auxiliary lifting platform	6435BWF-A7-B1	2
7	208106002	Pressed oil cup	M8	2
8	410276701	Down arm holder	6435BWF-C03-20	4
9	410276731	Shaft for piston rod	6435BWF-C03-23	2
10	410276721C	Middle shaft	6435BWF-C03-22	4
11	612019504	Supporting holder shaft	65012-A1-B5	4
12	410276711B	UP and down wheel	6435BWF-C03-21	8
13	205101094	Bearing	SF1-2540	8
14	410276813	Limit plate of the auxiliary lift	6435BWF-C11-1	2
15	410254430C	Padding pad	6604V2-A7-B4	4
16	205103003	Flange bearing	2525F	4
17	205101024	Bearing	3055	8
18	203103018	Locking nut	M24*3	4
19	204101012	Flat washer	M24	4
20	204301011	Type B circlip	M30	8
21	204301009	Circlip	M25(23.2)	4
22	202109080	Hex socket cylinder head screw	M10*70	8
23	204101006	Flat washer	M10	24
24	204201005	Spring washer	M10	8
25	203101006	Hex nut	M10	16
26	202109043	Hex socket cylinder head screw	M10*30	8
27	205101012	Bearing	2530	8
28	202110004	Hex socket button head screw	M8*12	4
29	208106001	Straight pressed oil cup	M8*1	9
30	614027585	Auxiliary platform extension	6435BWF-A7-B2	4

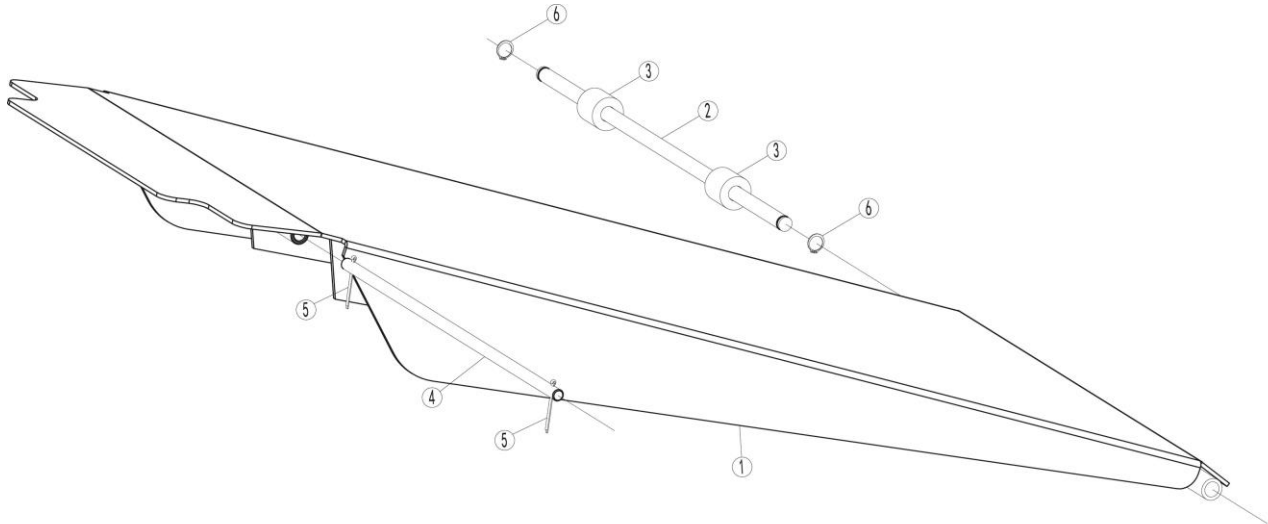

Pos.	CODE	Description	Specification	Qty
1	614027586C	Drive-on ramp	6435BWF-C18	2
2	410270201	Roller wheel shaft	6435B-A8-B3	2
3	420270250	Small roller wheel	MR30-A22-B5	4
4	410270191	Shaft	6435B-A8-B2	2
5	206201001	Cotter pin	φ2.5×30	4
6	204301004	Circlip	φ15	4