

3.0T CJ

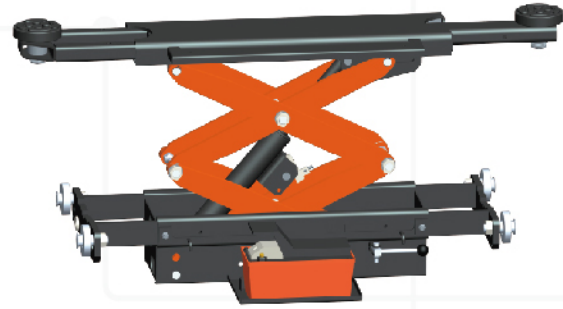

3.0T SCJ

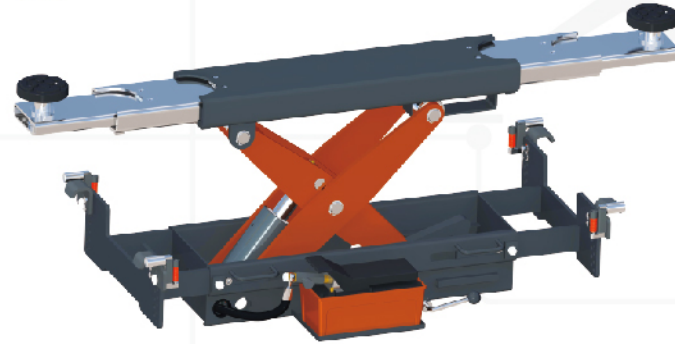

4.0T SCJ

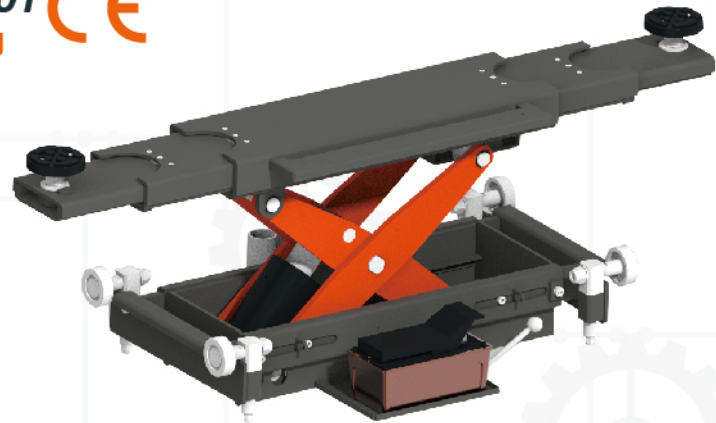

MAIN FEATURES

- Durable and compact scissor carrying structure.
- Adjustable width between support wheels to fit different widths between runways.
- Extendable jacking beam for various wheelbases.
- With manual release mechanical safety locking unit.
- Steel-made sliding rolls with ball-bearings move easily and smoothly on the track.
- Manual or pneumatic drive.

TECHNICAL DATA

| Model NO.              | CJ          |            | SCJ                   |                       |
|------------------------|-------------|------------|-----------------------|-----------------------|
| Type                   | Manual Pump | Air Pump   | Manual Pump           | Air Pump              |
| Lifting capacity       | 3.0T        | 3.0T       | 3.0T/4.0T             | 3.0T/4.0T             |
| Max stroke             | 450mm       | 450mm      | 310mm/270mm           | 310mm/270mm           |
| Initial height         | 230mm       | 230mm      | 245mm/260mm           | 245mm/260mm           |
| Platform width         | 805-1200mm  | 805-1200mm | 885-1180mm/780-1500mm | 885-1180mm/780-1500mm |
| Width between adapters | 800-1500mm  | 800-1500mm | 785-1700mm/900-1150mm | 785-1700mm/900-1150mm |
| Support beam           | Two stage   | Two stage  | Three stage           | Three stage           |
| Air supply             | /           | 6-8bar     | /                     | 6-8bar                |
| Rated oil pressure     | 24MPa       | 24MPa      | 24MPa                 | 24MPa                 |
| Weight                 | 160kg       | 160kg      | 170kg                 | 170kg                 |

\* Technical data and composition presented in this catalogue may vary. Pictures reproduced are only indicative.

OVERALL DIMENSION

